

Bottle filler with silver powder-coated finish & pedestal dual

Haws®



FEATURES & BENEFITS

BARRIER-FREE

Barrier-free capabilities combined with its ease of use allows for a number of installation location possibilities.

PUSH BUTTON VALVE

The push-button activated valve has an all stainless steel body, with chrome plated brass push button assembly which allows for front access to water stream adjustment, water control cartridge, and water supply strainer replacement without having to go through the bottom plate. Operating pressure range of 30 to 90 psi (2.1 to 6.2 bar).

BOTTLE FILLER

Hydration made easy with an industry leading 17" bottle area opening to allow more users access to this push button operated bottle filling station.

MODULAR CONFIGURATION

Bottle filler, drinking fountain, dog bowl and/or hose bib can be re-positioned, added or removed on site at any time. Side arm(s) can be placed high or low within its opening, and valve button position can be placed in any direction.

SPECIFICATIONS

Model 3620 modular outdoor, barrier-free pedestal bottle filler shall include a 3/16" phosphated-steel pedestal with silver powder-coating, two bottle filling stations, push-button operated stainless steel valves with front-accessible cartridge and flow adjustment, large-opening bottle filler with quick-fill 1 gpm flow rate, 100% lead-free waterways, polished chrome-plated vandal-resistant waste strainers, vandal-resistant access plate, integral mounting feet, and 1-1/2" slip waste.

OPTIONS

- Drinking Fountain Bowl, ODBF:** Model 3680, drinking fountain bowl assembly for the 3600 series modular outdoor pedestals. Available in three standard colors - order 3680-01 silver, 3680-02 blue, and 3680-03 green.
- Pedestal Arm, ODBF:** pedestal arm allows for the mounting of the 3690 series bottle fillers or the 3680 series drinking fountains. Includes the model 3655 bottom access plate. Available in three standard colors -order 3671-01 silver, 3671-02 blue, and 3671-03 green.
- Modular Outdoor Bottle Filler Dog Bowl:** Model 3670, dog bowl for the 3600 series modular outdoor pedestals. Available in three standard colors - order 3670-01 silver, 3670-02 blue, and 3670-03 green.
- Modular Outdoor Pedestal Lockable Hose Bib:** Model 3660, compression hose bib faucet housed in a lockable compartment for the 3600 series modular outdoor pedestals. Available in three standard colors - order 3660-01 silver, 3660-02 blue, and 3660-03 green.

APPLICATIONS

The 3620 offers a solution for the changing needs of outdoor settings as well as outdoor wheelchair access, appealing to all users through accessibility and safety. This outdoor bottle filler is ideal in areas such as parks, schools, and other outdoor areas where hydration facilities are needed. Model meets all current Federal Regulations for the disabled including those in the Americans with Disabilities Act, and complies with Prop 65. Certified by CSA to NSF/ANSI 61, section 9 and NSF/ANSI 372; and was evaluated to be compliant to US and Canada Plumbing Codes including Uniform Plumbing Code (UPC), International Plumbing Code (IPC) and National Plumbing Code of Canada (NPC).

Postadress:

TRÄDGÅRDSTEKNIK AB
Helsingborgsvägen 578, Varalöv
262 96 ÄNGELHOLM

Telefon : 0431-222 90
Bg.nr : 5743-7980
Org.nr : 556409-6120

URL:

www.tradgardsteknik.se
E-postadress:
info@tradgardsteknik.se

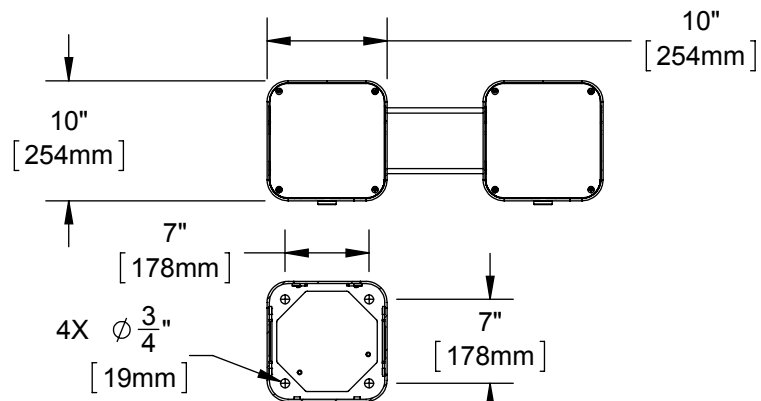

**SECTION A-A
INTERNAL PEDESTAL MOUNTING DETAIL**

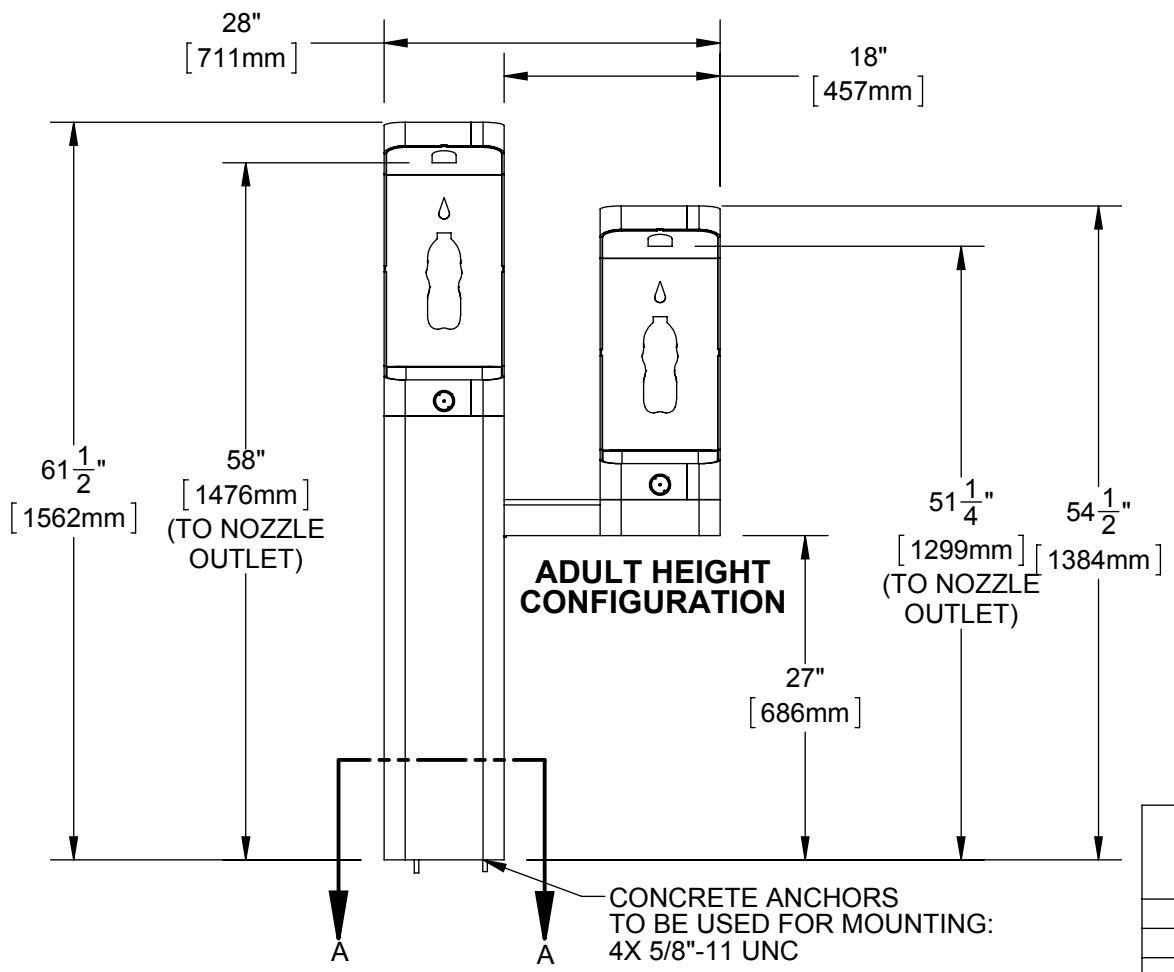

**ADULT HEIGHT
CONFIGURATION**

CONCRETE ANCHORS
TO BE USED FOR MOUNTING:
4X 5/8"-11 UNC

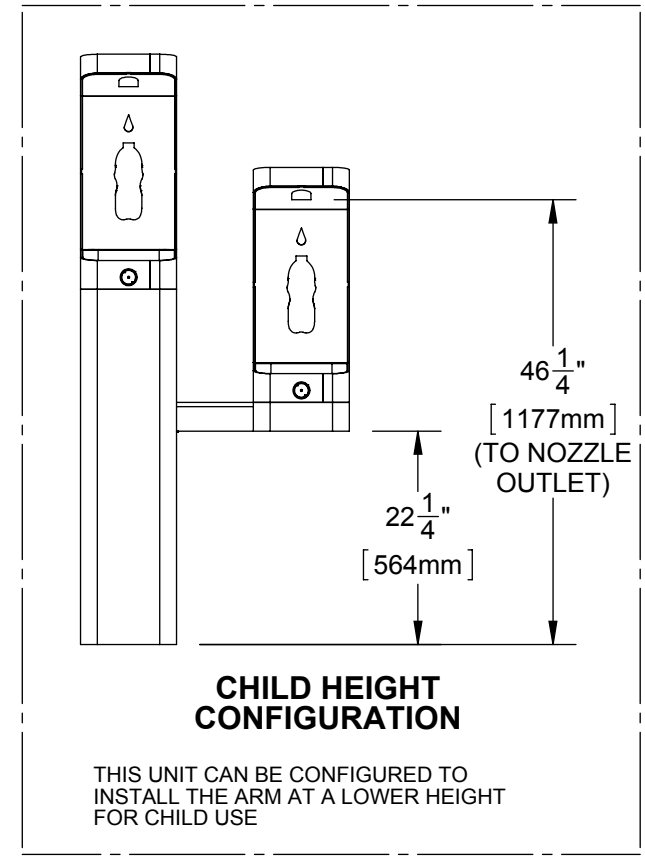

**CHILD HEIGHT
CONFIGURATION**

THIS UNIT CAN BE CONFIGURED TO
INSTALL THE ARM AT A LOWER HEIGHT
FOR CHILD USE

SCALE:		DRAWING TYPE:		SIZE: A		SHEET 1 OF 1	
--------	--	---------------	--	---------	--	--------------	--