

BARONESS
Quality on Demand

LM315GC

Triple Greens Mower (Diesel Model)

Service manual

Introduction

This manual describes about the procedures of maintenance and malfunction diagnosis etc. of this machine. Items of description are categorized per system for representative maintenance contents. As for repair items specified by the manufacturers in the hydraulic system, engine, etc., their respective disassembling and maintenance procedures are not described.

For operation, handling and adjustment instruction, please refer to the Owner's Operating Manual. Be sure to also read the Owner's Operating Manual for the engine, battery, etc. See the parts catalog for required parts.

Caution

The information described in this manual is subject to change for improvement without prior notice. Note that the Baroness product warranty may not apply to defects caused by the use of parts from other companies.

Warning Symbols

This manual uses the following warning symbols for handling precautions that are important for your safety.



696cq5-001

Warning symbol

This symbol indicates the articles regarding “Danger,” “Warning,” or “Caution.” Those articles describe important safety precautions and so read them carefully to understand completely before operating the machine. Failure to adequately follow these safety precautions may cause an accident.

Danger

This symbol indicates that serious injury or death will occur if the warning is ignored.

Warning

This symbol indicates that serious injury or death may occur if the warning is ignored.

Caution

This symbol indicates that injury or damage to property may occur if the warning is ignored.

Important

This symbol indicates precautions on the mechanism of the machine.

LM315GC

Contents

Safe Operating Practices..... Page 1-2

Training.....Page 1-2

Preparation..... Page 1-2

Operation..... Page 1-3

Maintenance and storage..... Page 1-4

Safety Signs and Instruction Signs..... Page 1-5

About Safety Signs and Instruction
Signs.....Page 1-5

Safety

Failure to adequately follow these safety precautions may cause an accident resulting in injury or death.

Danger

This machine is designed to ensure safe operation and has been tested and inspected thoroughly before shipment from the factory. The machine is equipped with safety devices to prevent accidents.

However, whether the machine demonstrates its original performance level depends on the manner in which it is operated and handled, as well as the manner in which it is managed on a daily basis.

Inappropriate use or management of the machine may result in injury or death.

Observe the following safety instructions to ensure safe operation.

Safe Operating Practices

The following instructions include the ones from CEN standard EN 836: 1997, ISO standard 5395: 1990, and ANSI B71.4-2004.

Training

1. Read the Owner's operating Manual and other training material carefully. Be familiar with the controls, safety signs, and the proper use of the equipment.
2. If the operator or mechanic can not read English it is the owner's responsibility to explain this material to them.
3. All operators and mechanics should seek and obtain professional and practical instruction. The owner is responsible for training the users. Such instruction should emphasize.
 - [1] The need for care and concentration when working with ride-on machines.
 - [2] Control of a ride-on machine sliding on a slope will not be regained by the application of the brake. The main reasons for loss of control are
 - Insufficient wheel grip
 - Being driven too fast
 - Inadequate braking
 - The type of machine is unsuitable for its task

- Lack of awareness of the effect of ground conditions, especially slopes
- Incorrect hitching and load distribution

4. Never allow untrained personnel to service machine. Local regulations may restrict the age of the operator.
5. The owner/user can prevent and is responsible for accidents or injuries occurring to themselves, other people, or property.
6. Keep in mind that the owner, operator, and mechanic are responsible for accidents or hazards occurring to other people or their property.

Preparation

1. Evaluate the terrain to determine what accessories and attachments are needed to properly and safely perform the job. Only use accessories and attachments approved by the manufacturer.
2. While operating, always wear substantial footwear, long trousers, hard hat, safety glasses, and ear protection. Long hair, loose clothing, or jewelry may get tangled in moving parts. Do not operate the equipment when barefoot or wearing open sandals.
3. Inspect the area where the equipment is to be used and remove all objects such as rocks, toys and wire which can be thrown by the machine.
4. Exercise care in the handling of fuel.

Warning

Warning-Fuel is highly flammable. Take the following precautions.

- [1] Store fuel in containers specifically designed for this purpose.
- [2] Add fuel before starting the engine. Never remove the cap of the fuel tank or add fuel while the engine is running or when the engine is hot.
- [3] Refuel outdoors only and do not smoke while refueling.
- [4] If fuel is spilled, do not attempt to start the engine but move the machine away from the area of spillage and avoid creating any source of ignition until petrol vapours have dissipated.

- [5] Replace all fuel tanks and container caps securely.
- 5. Check that operator's presence controls, safety switches and shields are attached and functioning properly. Do not operate unless they are functioning properly.
- 6. If the brake operation is faulty or the parking brake lever has noticeable play, be sure to adjust or repair them before operating the machine.
- 7. Replace faulty mufflers.
- 6. Do not change the engine governor settings or overspeed the engine. Operating the engine at excessive speed may increase the hazard of personal injury.
- 7. Do the following before leaving the operator's position.
 - [1] Stop on level ground.
 - [2] Disengage the power take-off and lower the attachments.
 - [3] Change into neutral and set the parking brake.
 - [4] Stop the engine and remove the key.

Operation

- 1. Do not operate the engine in a confined space where dangerous carbon monoxide fumes can collect.
- 2. Only operate in good light, keeping away from holes and hidden hazards.
- 3. Before attempting to start the engine, disengage all attachments, shift into neutral, and engage the parking brake. Only start engine from the operator's position. Use seat belts if provided.
- 4. Remember there is no such thing as a safe slope. Travel on grass slopes requires particular care. To guard against overturning:
 - [1] Do not stop or start suddenly when going up or downhill.
 - [2] Engage clutch slowly, always keep machine in gear, especially when traveling downhill.
 - [3] Machine speeds should be kept low on slopes and during tight turns.
 - [4] Stay alert for humps and hollows and other hidden hazards.
 - [5] Never operate across the face of the slope, unless the machine is designed for this purpose.
 - [6] Never drive the machine on a slope with an angle of gradient that is greater than that specified or in a place where there is a danger of the machine slipping.
- 5. Never operate the machine with damaged guards, shields, or without safety protective devices in place. Be sure all interlocks are attached, adjusted and functioning properly.
- 8. Disengage the drive to attachments, stop the engine, and remove the ignition key in the following conditions.
 - [1] Before refueling.
 - [2] Before removing the grass catcher/catchers.
 - [3] Before making height adjustment unless adjustment can be made from the operator's position.
 - [4] Before cleaning blockages.
 - [5] Before checking, cleaning, or working the machine.
 - [6] After striking a foreign object or if an abnormal vibration occurs. Inspect the machine for damage and make repairs before restarting and operating the equipment.
- 9. Keep hands and feet away from the cutting units and the rotating parts.
- 10. Look behind and down before backing up to be sure of a clear path.
- 11. Do not carry passengers.
- 12. Never operate while people, especially children, or pets are nearby.
- 13. Slow down and use caution when making turns and crossing roads and sidewalks.
- 14. Stop the blades rotating before crossing surfaces other than grass.
- 15. Disengage drive to attachments when transporting or not in use.
- 16. When using any attachments, never direct discharge of material toward bystanders nor allow anyone near the machine while in operation.
- 17. Do not operate the machine under the influence of alcohol or drugs.

Safety

18. Take care when loading or unloading the machine into a trailer or a truck. Load or unload the machine in a flat and safe place. Before loading or unloading, set the parking brake on the truck or trailer, stop the engine, and chock the wheels.
When transporting the machine on a truck or a trailer, set the parking brake, stop the engine, and fasten the machine to the truck with a rope or other suitable restraining device that has sufficient strength.
When using a running board, select one with sufficient strength, length, and width and that will not cause the machine to slip.
19. Close the fuel valve before transporting the machine.
20. Use care when approaching blind corners, shrubs, trees, or other objects that may obscure vision.
21. Do not take your eyes off the road ahead. Do not operate the machine with no hands.
22. Reduce the throttle setting during engine run-out and, if the engine is provided with a shut-off valve, turn the fuel off at the conclusion of operation.
9. Never allow untrained personnel to service machine.
10. Allow the engine/muffler to cool before checking/maintenance.
11. Appropriately manage and correctly use the tools necessary for servicing or adjusting the machine.
12. Use jack stands to support components when required.
13. Carefully release pressure from components with stored energy.
14. Be sure to depressurize the hydraulic system before performing maintenance operations on it such as removing hydraulic equipment.
15. Check whether line connectors in the hydraulic system are properly tightened. Before applying hydraulic pressure, check the connections of the hydraulic pressure lines and the condition of the hoses.
16. When checking the hydraulic circuit for pinhole leaks or oil leakage from nozzles, do not use your hands. Use items such as paper or corrugated cardboard to find leakage points. Be extremely careful with high-pressure oil as it may pierce your skin, resulting in an injury.
If fluid is injected into the skin it must be surgically removed within a few hours by a doctor familiar with this form of injury or gangrene may result.

Maintenance and storage

1. Disengage drives on level ground, lower the attachments, set parking brake, stop engine and remove key from ignition. Wait for all movement to stop before adjusting, cleaning or repairing.
2. When machine is to be parked, stored, or left unattended, lower the cutting units unless a positive mechanical lock is provided.
3. To reduce the fire hazard, keep the engine, silencer/muffler, battery compartment fuel storage area, cutting unit and drives free of grass, leaves, or excessive grease. Clean up oil or fuel spillage.
4. Allow the engine to cool before storing in any enclosure.
5. Only cover the machine with a sheet after hot parts have sufficiently cooled down.
6. Never store the equipment with fuel in the tank inside a building where fumes may reach an open flame or spark.
7. If the engine is provided with a shut-off valve, shut off valve while storing or transporting.
8. Do not store fuel near flames.
17. Disconnect battery before making any repairs. Disconnect the negative terminal first and the positive last. Reconnect positive first and negative last.
18. Make sure that parts such as wires are not touching each other and that their covers have not come off.
19. Use care when checking the cylinders/reels and bed knives.
 - [1] Wear gloves and use caution when servicing them.
 - [2] Be careful during adjustment of the machine to prevent entrapment of the fingers between moving blades and fixed parts of the machine.
20. On multi-cylinder/multi-reel machines take care as rotating one cylinder/reel can cause other cylinder/reels to rotate.
21. Keep hands and feet away from moving parts. If possible, do not make adjustments with the engine running.

22. Charge batteries in an open well ventilated area, away from spark and flames. Unplug charger before connecting or disconnecting from battery. Wear protective clothing and use insulated tools.
23. Keep all parts in good working condition and all hardware tightened. Replace all worn or damaged decals.
24. Keep all nuts, bolts and screws tight to be sure the equipment is in safe working condition.
25. Check the grass catcher frequently for wear or deterioration.
26. If the fuel tank has to be drained, do this outdoors.

Safety Signs and Instruction Signs

About Safety Signs and Instruction Signs

 Warning

Safety decals and instruction decals are attached to this machine. Make sure that they are preserved in their entirety. If they are damaged, become dirty, or peel off, replace them with new ones.

Part numbers for decals that need to be replaced are listed in the parts catalog.

Waste Disposal..... Page 2-2

About the Waste disposal..... Page 2-2

Disposal

Waste Disposal

About the Waste disposal

Make sure that waste generated when servicing or repairing the machine is disposed of in accordance with local regulations.

(e.g. waste oil, antifreeze batteries, rubber products, and wires etc.)

Maintenance standards and maintenance

Unit conversion.....Page 3-2

Inch-millimeter conversion table..... Page 3-2

US unit-SI unit conversion table.....Page 3-3

Maintenance standards.....Page 3-4

List of Maintenance Specifications..... Page 3-4

Tightening torques..... Page 3-6

Standard tightening torques..... Page 3-6

Principal tightening torques Page 3-8

Jacking up the machine..... Page 3-10

About the Jacking up the machine..... Page 3-10

Jack-up Points..... Page 3-10

Greasing..... Page 3-10

About Greasing.....Page 3-10

Greasing Points..... Page 3-11

Maintenance standards and maintenance

Unit conversion

Inch-millimeter conversion table

1 mm = 0.03937 in

1 in = 25.4 mm

Fractions		Decimals	mm	Fractions		Decimals	mm
	1/64	0.015625	0.397		33/64	0.515625	13.097
	1/32	0.03125	0.794		17/32	0.53125	13.494
	3/64	0.046875	1.191		35/64	0.546875	13.891
1/16		0.0625	1.588	9/16		0.5625	14.288
	5/64	0.078125	1.984		37/64	0.578125	14.684
	3/32	0.09375	2.381		19/32	0.59375	15.081
	7/64	0.109275	2.778		39/64	0.609375	15.478
1/8		0.1250	3.175	5/8		0.6250	15.875
	9/64	0.140625	3.572		41/64	0.640625	16.272
	5/32	0.15625	3.969		21/32	0.65625	16.669
	11/64	0.171875	4.366		43/64	0.671875	17.066
3/16		0.1875	4.762	11/16		0.6875	17.462
	13/64	0.203125	5.159		45/64	0.703125	17.859
	7/32	0.21875	5.556		23/32	0.71875	18.256
	15/64	0.234375	5.953		47/64	0.734375	18.653
1/4		0.2500	6.350	3/4		0.7500	19.050
	17/64	0.265625	6.747		49/64	0.765625	19.447
	9/32	0.28125	7.144		25/32	0.78125	19.844
	19/64	0.296875	7.541		51/64	0.796875	20.241
5/16		0.3125	7.938	13/16		0.8125	20.638
	21/64	0.328125	8.334		53/64	0.828125	21.034
	11/32	0.34375	8.731		27/32	0.84375	21.431
	23/64	0.359375	9.128		55/64	0.859375	21.828
3/8		0.3750	9.525	7/8		0.8750	22.225
	25/64	0.390625	9.922		57/64	0.890625	22.622
	13/32	0.40625	10.319		29/32	0.90625	23.019
	27/64	0.421875	10.716		59/64	0.921875	23.416
7/16		0.4375	11.112	15/16		0.9375	23.812
	29/64	0.453125	11.509		61/64	0.953125	24.209
	15/32	0.46875	11.906		31/32	0.96875	24.606
	31/64	0.484375	12.303		63/64	0.984375	25.003
1/2		0.5000	12.700	1		1.000	25.400

Maintenance standards and maintenance

US unit-SI unit conversion table

To Convert			Into		Multiply By
Linear Measurement	Miles	mi	Kilometers	km	1.609
	Yards	yd	Meters	m	0.9144
	Feet	ft	Meters	m	0.3048
	Feet	ft	Centimeters	cm	30.48
	Inches	in	Meters	m	0.0254
	Inches	in	Centimeters	cm	2.54
	Inches	in	Millimeters	mm	25.4
Area	Square Miles	mile ²	Square Kilometers	km ²	2.59
	Square Feet	ft ²	Square Meters	m ²	0.0929
	Square Inches	in ²	Square Centimeters	cm ²	6.452
	Acre	ac	Hectare	ha	0.4047
Volume	Cubic Yards	yd ³	Cubic Meters	m ³	0.7646
	Cubic Feet	ft ³	Cubic Meters	m ³	0.02832
	Cubic Inches	in ³	Cubic Centimeters	cm ³	16.39
Weight	Tons (Short)	sh tn	Metric Tons	ton	0.9078
	Pounds	lb	Kilograms	kg	0.4536
	Ounces (Avdp.)	oz	Grams	g	28.3495
Pressure	Pounds/Sq. In.	psi	Kilopascal	kPa	6.895
	Pounds/Sq. In.	psi	Bar	mdyn/cm ²	0.069
Work	Foot-pounds	lb-ft	Newton-Meters	N-m	1.356
	Foot-pounds	lb-ft	Kilogram-Meters	kgf-m	0.1383
	Inch-pounds	lb-in	Kilogram-Centimeters	kgf-cm	1.152144
Liquid Volume	Quarts	qt (us)	Liters	l	0.9463
	Gallons	gal (us)	Liters	l	3.785
Liquid Flow	Gallons/Minute	gal/min	Liters/Minute	l/min	3.785
Temperature	Fahrenheit	°F	Celsius	°C	1. Subtract 32° 2. Multiply by 5/9

Maintenance standards and maintenance

Maintenance standards

List of Maintenance Specifications

LM315GC

Engine	Engine model	Kubota D722-E4B	
	No load rpm	1,500 - 3,270 rpm	
	Quantity of engine oil	2.8 dm ³ (2.8 L) (0.74 U.S. gal.) (including filter)	API Service grade class CF or higher, SAE Viscosity grade 10W-30
	Coolant capacity	3.0 dm ³ (3.0 L) (0.79 U.S. gal.) (including reserve tank)	
Main body (including hydraulic and electrical systems)	Fuel tank capacity	20.0 dm ³ (20.0 L) (5.28 U.S. gal.)	JIS No. 2 diesel fuel (Low sulfur or ultra-low sulfur diesel fuel only)
	Hydraulic tank capacity	16.0 dm ³ (16.0 L) (4.23 U.S. gal.)	Shell Tellus S2M46 or equivalent (ISO VG46)
	Parking Brake Switch	Slight clearance	A clearance between the switch contact point and the parking brake lever when the parking brake lever is at the 4th notch
	Proximity Sensor (Reel rotation start position detection)	0 mm (0 in)	Horizontal distance between the sensor tip and the tip of the right front up/down cylinder when the mower unit is lowered
		1.0 - 2.5 mm (0.04 - 0.10 in)	Clearance between the sensor detection part and the tip of the right front up/down cylinder when the mower unit is lowered
	Proximity Sensor (Mower unit up position detection)	415.0 mm (16.34 in)	Distance between the tip of the rear mower arm and the floor when the mower unit is raised
		1.0 - 2.5 mm (0.04 - 0.10 in)	Clearance between the sensor detection part and the cam when the mower unit is raised
		192.0 mm (7.56 in)	Length of the mower up/down cam adjustment rod
	Proximity Sensor (Mower unit down position detection)	285.0 mm (11.22 in)	Distance between the tip of the rear mower arm and the floor when the mower unit is lowered
		1.0 - 2.5 mm (0.04 - 0.10 in)	Clearance between the sensor detection part and the cam when the mower unit is lowered
		192.0 mm (7.56 in)	Length of the mower up/down cam adjustment rod
	Proximity Switch	5.0 mm (0.20 in)	Clearance between the switch and the plastic magnet when the traveling pedal is neutral
	Electromagnetic clutch	0.3 - 0.6 mm (0.01 - 0.02 in)	Clearance between the clutch rotor main body and the armature board when the electromagnetic clutch is not energized

Maintenance standards and maintenance

Main body (including hydraulic and electrical systems)	Limit switch (mower pedal switch)	75.0 mm (2.95 in)	Distance between the pedal back joint and the step when the mower pedal is released
	Battery	Diesel Model: 55B24 L (BCI GROUP SIZE 51R: Recommended equivalent product EXIDE 51R-60) Gasoline Model: 40B19L (BCI GROUP SIZE U1R: Recommended equivalent product EXIDE GTX-R)	
	Tire pneumatic pressure	Front wheel: 80 kPa (11.60 lb-in ²)	Smooth 18 x 9.50-8 2P
		Front wheel (option) 100 kPa (14.50 lb-in ²)	Pillow Dia 18 x 8.50-8 4P
		Rear wheel: 80 kPa (11.60 lb-in ²)	Smooth 18 x 9.50-8 2P
Spring compression length (neutral adjustment)	55 mm (2.17 in)	Compression spring	

* The factory default maximum engine rpm is 3,000 rpm.

Maintenance standards and maintenance

Tightening torques

Standard tightening torques

Bolts and Nuts

Important

A number of bolts are used in each part of this machine.
Be sure to re-tighten the bolts and nuts, because they may be loosened at the earlier stage of the use.

As to the bolts and nuts without any special instruction, tighten them in appropriate tightening torque with proper tool.

Too much tightening may cause the looseness or damage of the screw.

The strength of tightening is determined by types of screws, strength, the friction of thread face or base face and others.

The table below is for the galvanized or parkerized bolts.

In case that the strength of internal thread is weak, it is not applied.

Do not use rusty or sand attached "screw."

Otherwise, it may cause insufficient tightening even if you apply the specified tightening torque.

The friction of the screw face becomes higher and the tightening torque is canceled out by the friction, therefore sufficient tightening cannot be applied.

If "screw" is wet by water or oil, do not tighten it with normal tightening torque.

If the screw is wet, the torque coefficient will get smaller and it may result in too much tightening.

Too much tightening may cause looseness by the screw stretched or result in damage.



Do not use a bolt experienced too much burden.

Using the impact wrench requires the skill.

Do exercise as much as possible for steady tightening.

Nominal diameter	General bolt		
	Strength classification 4.8		
			
	N-m	kgf-cm	lb-in
M5	3 - 5	30.59 - 50.99	26.55 - 44.26
M6	7 - 9	71.38 - 91.77	61.96 - 79.66
M8	14 - 19	142.76 - 193.74	123.91 - 168.17
M10	29 - 38	295.71 - 387.49	256.68 - 336.34
M12	52 - 67	530.24 - 683.20	460.25 - 593.02
M14	70 - 94	713.79 - 958.52	619.57 - 831.99
M16	88 - 112	897.34 - 1142.06	778.89 - 991.31
M18	116 - 144	1,182.85 - 1,468.37	1,026.72 - 1,274.54
M20	147 - 183	1,498.96 - 1,866.05	1,301.10 - 1,619.73
M22	295	3,008.12	2,611.05
M24	370	3,772.89	3,274.87
M27	550	5,608.35	4,868.05
M30	740	7,545.78	6,549.74

Maintenance standards and maintenance

Nominal diameter	Heat-treated bolt					
	Strength classification 8.8			Strength classification 10.9		
	 tib3yb-002			 tib3yb-003		
	N-m	kgf-cm	lb-in	N-m	kgf-cm	lb-in
M5	5 - 7	50.99 - 71.38	44.26 - 61.96	7 - 10	71.38 - 101.97	61.96 - 88.51
M6	8 - 11	81.58 - 112.17	70.81 - 97.36	14 - 18	142.76 - 183.55	123.91 - 159.32
M8	23 - 29	234.53 - 295.71	203.57 - 256.68	28 - 38	285.52 - 387.49	247.83 - 336.34
M10	45 - 57	458.87 - 581.23	398.30 - 504.51	58 - 76	591.43 - 774.97	513.36 - 672.68
M12	67 - 85	683.20 - 866.75	593.02 - 752.34	104 - 134	1,060.49 - 1,366.40	920.50 - 1186.03
M14	106 - 134	1,080.88 - 1,366.40	938.21 - 1,186.03	140 - 188	1,427.58 - 1,917.04	1,239.14 - 1,663.99
M16	152 - 188	1,549.94 - 1,917.04	1,345.35 - 1,663.99	210 - 260	2,141.37 - 2,651.22	1,858.71 - 2,301.26
M18	200 - 240	2,039.40 - 2,447.28	1,770.20 - 2,124.24	280 - 340	2,855.16 - 3,466.98	2,478.28 - 3,009.34
M20	245 - 295	2,498.27 - 3,008.12	2,168.50 - 2,611.05	370 - 450	3,772.89 - 4,588.65	3,274.87 - 3,982.95
M22	-	-	-	530	5,404.41	4,691.03
M24	-	-	-	670	6,831.99	5,930.17
M27	-	-	-	1,000	10,197.00	8,851.00
M30	-	-	-	1,340	14,628.78	11,860.34

Note:

The same values are applied to "fine screw thread."

Hydraulic hose

The tightening torques for union joints and union adaptors with parallel pipe threads (G, PF) are shown in the table below.

A union joint or adaptor will not become loose or leak as long as it is tightened by the specified torque.

If fluid leaks from the sealed portion, do not attempt to tighten the union joint or adaptor forcibly.

Examine whether any foreign matter or scratches are present on the seat surface.

Tightening a union joint or adaptor forcibly could damage the connection of the joints.

When tightening a union joint or adaptor, use a torque wrench where possible and firmly tighten it by an appropriate torque.

Nominal diameter of the hose size	Nominal diameter of the parallel pipe threads (PF)	Tightening torque		
		N-m	kgf-cm	lb-in
6	1/4	24.50	250	221.28
9	3/8	49.03	500	564.91
12	1/2	58.84	600	677.89
15	3/4	117.68	1200	1,355.78
19	3/4	117.68	1200	1,355.78
25	1	137.30	1400	1,581.74
32	1-1/4	166.72	1700	1,920.69
38	1-1/2	205.94	2100	2,372.61
50	2	245.17	2500	2,824.54

Maintenance standards and maintenance

Fittings with parallel threads (O-ring seal type)

The tightening torques for fittings with parallel threads (O-ring seal method) are shown in the table below.

Tightening an adjustable joint forcibly with a spanner or other such tool to secure it to a set position could damage the adjustable joint, its washers, and other parts. Be sure to tighten an adjustable joint to the torque appropriate to its size.

Nominal diameter of thread	Tightening torque		
	N-m	kgf-cm	lb-in.
1/4	34.32 - 49.03	350 - 500	309.79 - 442.55
3/8	68.65 - 78.45	700 - 800	619.57 - 708.08
1/2	98.07 - 117.68	1000 - 1200	885.10 - 1,062.12
3/4	147.10 - 176.52	1500 - 1800	1,327.65 - 1,593.18
1	245.17 - 274.59	2500 - 2800	2,212.75 - 2,478.28
1-1/4	294.20	3000	2,655.30
1-1/2	294.20	3000	2,655.30
2	392.27	4000	3,540.40

Principal tightening torques

Tightening Torque by Model

LM315GC

Tighten the following bolts and nuts at the torque specified in the table.

For thread locking adhesive, apply a middle strength thread locker (ThreeBond 1322 anaerobic adhesives).

Location	Code	Part name	Tightening torque			Thread locking adhesive	
			N-m	kgf-cm	lb-in		
Front frame	K0010080202	Bolt, heat-treated M8-20	23 - 38	234.53 - 387.49	203.57 - 336.34	-	
Engine coupling	Joint	K0010080152	Bolt, heat-treated M8-15	23 - 38	234.53 - 387.49	203.57 - 336.34	-
	Belt collar	K0010080302	Bolt, heat-treated M8-30	23 - 38	234.53 - 387.49	203.57 - 336.34	-
Gasoline engine	Engine rack	K0000080402	Bolt, M8-40	14 - 19	142.76 - 193.74	123.91 - 168.17	○
		K0003080452	Bolt, M8-45	14 - 19	142.76 - 193.74	123.91 - 168.17	○
Diesel engine	Engine mount	K0017100252	Bolt, heat-treated, small, 10-25 P1.25	45 - 57	1835.46 - 2039.40	1593.18 - 1770.20	-
	Wire mounting adjuster	K0011100302	Bolt, heat-treated M10-30P1.25	45 - 57	1835.46 - 2039.40	1593.18 - 1770.20	-
	Muffler mounting adjuster	K0011100352	Bolt, heat-treated M10-35P1.25	45 - 57	1835.46 - 2039.40	1593.18 - 1770.20	-
	Pulley mounting adjuster	K0010080202	Bolt, heat-treated M8-20	23 - 38	234.53 - 387.49	203.57 - 336.34	-

Maintenance standards and maintenance

Location		Code	Part name	Tightening torque			Thread locking adhesive
				N-m	kgf-cm	lb-in	
Diesel engine	Engine pulley D	K0010080202	Bolt, heat-treated M8-20	23 - 38	234.53 - 387.49	203.57 - 336.34	-
	Wheel	K0010100302	Bolt, heat-treated M10-30	58 - 76	591.43 - 774.97	513.36 - 672.68	-
Front wheel	Wheel mounting base	K0138240002	24 slotted nut high P1.5	180 - 200	1835.46 - 2039.40	1593.18 - 1770.20	-
	Motor	K0000120502	Bolt, M12-50	52 - 67	530.24 - 683.20	460.25 - 593.02	-
3WD rear wheel	Wheel	K0013101202	Bolt, heat-treated M10-120	58 - 76	591.43 - 774.97	513.36 - 672.68	-
	Wheel mounting base	K0138240002	24 slotted nut high P1.5	180 - 200	1835.46 - 2039.40	1593.18 - 1770.20	-
	Brake Assy	K0010080252	Bolt, heat-treated M8-25	14 - 19	142.76 - 193.74	123.91 - 168.17	-
	Wheel	K0010100302	Bolt, heat-treated M10-30	45 - 57	1835.46 - 2039.40	1593.18 - 1770.20	-
2WD rear wheel	Brake drum	K0010100302	Bolt, heat-treated M10-30	45 - 57	1835.46 - 2039.40	1593.18 - 1770.20	-
	Reel shaft	LM315GB2102 Z0	Reel gear fixing nut	7	71.38	61.96	-
Mower	Reel shaft (with Groomer)	LM315GB2101 Z0	20-tooth reel gear	7	71.38	61.96	-
	Bed knife (Bottom blade)	K0071000222	Screw, heat-treated flathead M6-12	7 - 9	71.38 - 91.77	61.96 - 79.66	-
	Groomer reel	K0160000602	17 special nut P1M4	5 - 10	50.99 - 101.97	44.26 - 88.51	-
	Gearbox	LM315GA1817 Z0	Reverse shaft	52 - 67	530.24 - 683.20	460.25 - 593.02	○
		LM315GA1816 Z0	Intermediate shaft	52 - 67	530.24 - 683.20	460.25 - 593.02	○
	Front roller	K6083000042	Connected pin, 15-19	29 - 38	295.71 - 387.49	256.68 - 336.34	-
		K0071000152	Bolt, Left-handed Thread	29 - 38	295.71 - 387.49	256.68 - 336.34	-
	Groomer mounting	K6809000270	Screw	18	183.55	159.32	-
		LM315GA1835 Z0	Mower mounting bolt, left	20	203.94	177.02	-
		LM315GA1836 Z0	Mower mounting bolt, right	20	203.94	177.02	-
ROPS pillar right/left	K0010120402	Bolt, heat-treated M12-40	58 - 76	591.43 - 774.97	513.36 - 672.68	-	

Maintenance standards and maintenance

Jacking up the machine

About the Jacking up the machine

⚠ Warning

When replacing a tire or beginning any other maintenance or repairs, be sure to chock the wheels to prevent the machine from moving. Before jacking up the machine, park it on a hard, flat surface such as a concrete floor and remove any obstacles that could prevent you from performing the work safely. When necessary, use an appropriate chain block, hoist, or jack. Support the machine securely with jack stands or appropriate blocks. Failure to do so may cause the machine to move or fall, resulting in injury or death.

Use the jack-up points identified in this manual when jacking up the machine. Only place a jack under the jack-up points specified. Placing a jack at any other point could result in damage to the frame or other parts.

Jack-up Points

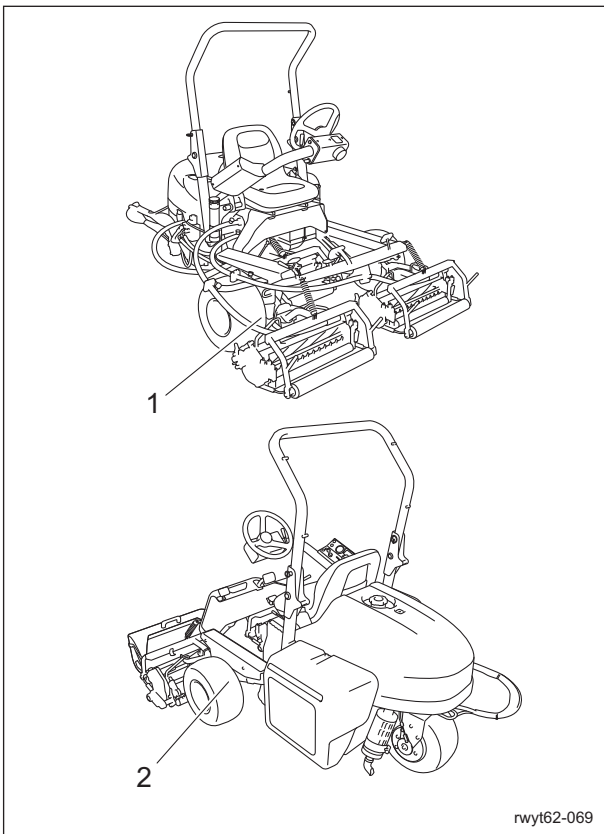

1	Front right frame
2	Front left frame
3	Engine mount frame

1. Front right frame

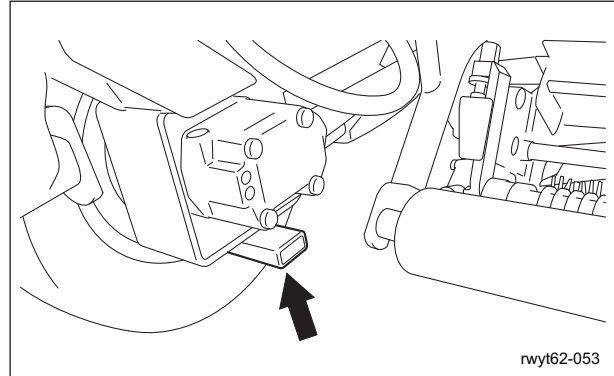

2. Front left frame

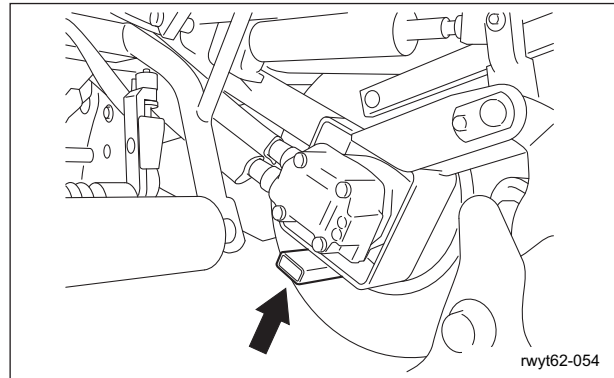

3. Engine mount frame

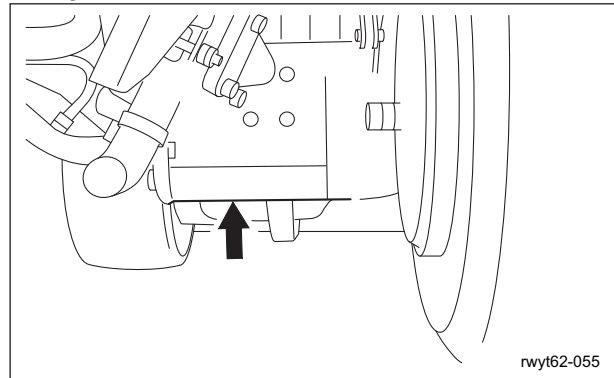

Greasing

About Greasing

Since there may be adhesion or damage due to lack of grease on moving parts, they must be greased.

Add urea-based No. 2 grease in accordance with the Maintenance Schedule.

Maintenance standards and maintenance

Other locations where the specified grease or lubricant is used are indicated in "Greasing Points".

Add grease using the specified grease or lubricant.

Greasing Points

Grease nipples are installed in the following locations.

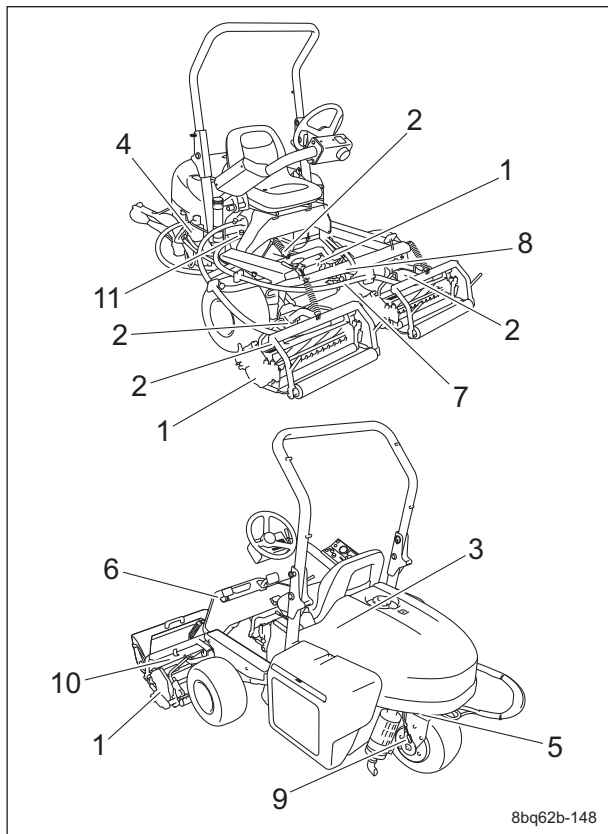

Greasing Points_001

	Location	No. of greasing points
1	Mower unit	36
2	Mower arm fulcrum	6
3	Belt tension lever	1
4	Neutral position area	1
5	Rear wheel pivot	1
6	Mower pedal shaft fulcrum	1
7	Flexible wire bracket	1
8	Traveling pedal shaft fulcrum	1
9	Rear wheel brake lever shaft	1
10	Flexible wire edge	3
11	Flexible wire	6

1. Mower unit

Each mower unit has 12 points (6 A and 6 B points).

Add grease to A and B every 8 and 50 hours, respectively.

Right

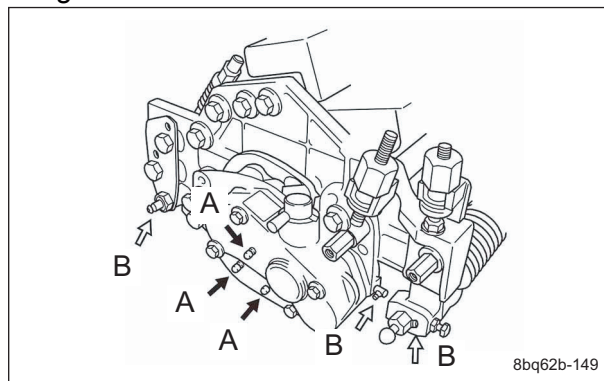

Greasing Points_002

Left

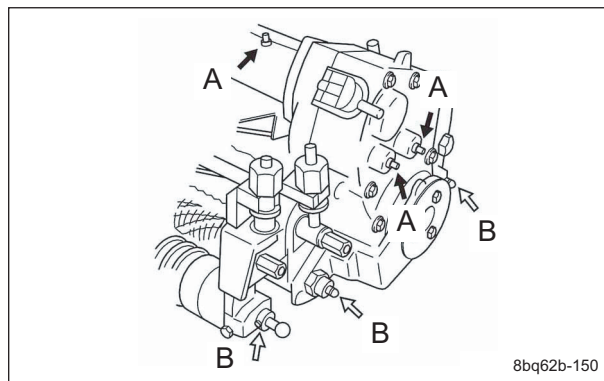

Greasing Points_003

2. Mower arm fulcrum

[1] Front mower unit

There are two greasing points on each mower unit.

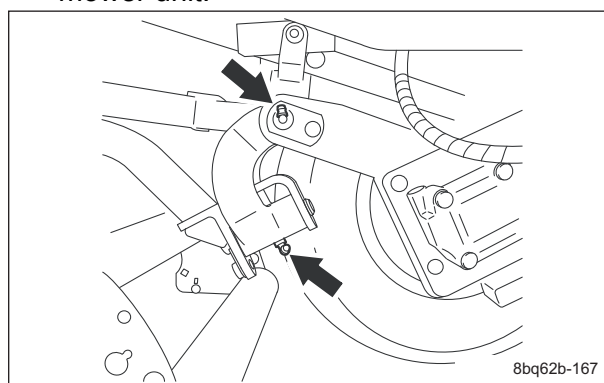

Greasing Points_004

Maintenance standards and maintenance

[2] Rear mower unit
There are two locations.

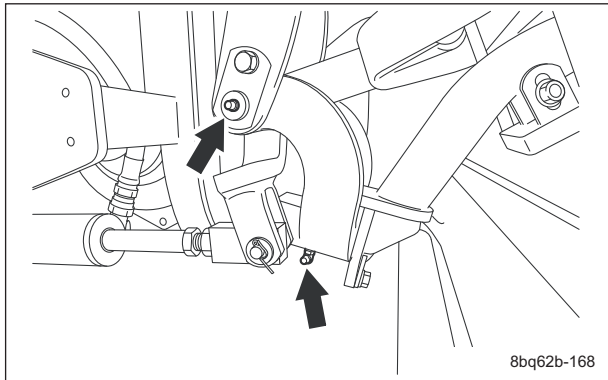

Greasing Points_005

8bq62b-168

3. Belt tension lever

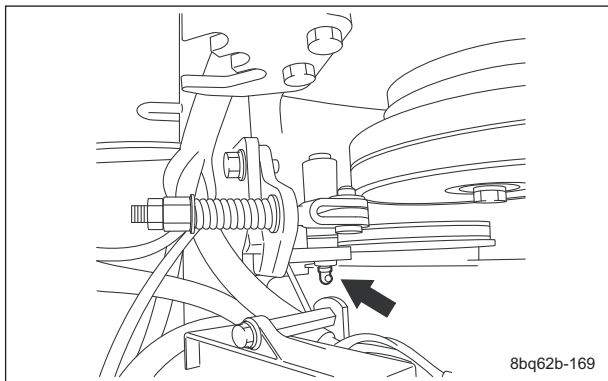

Greasing Points_006

8bq62b-169

4. Neutral position area

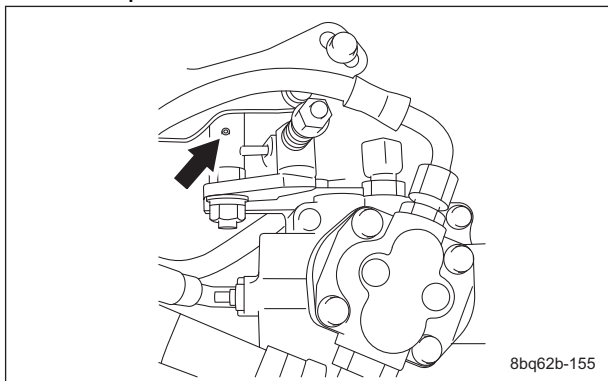

Greasing Points_007

8bq62b-155

5. Rear wheel pivot

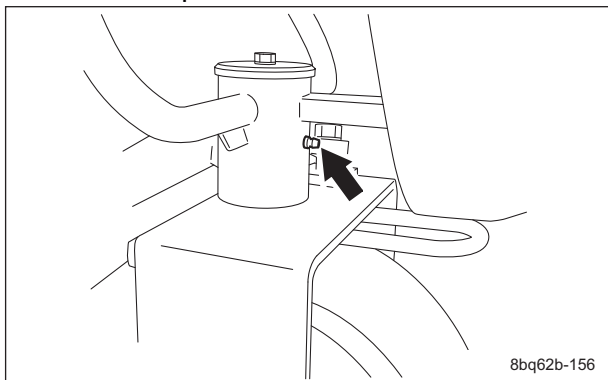

Greasing Points_008

8bq62b-156

6. Mower pedal shaft fulcrum

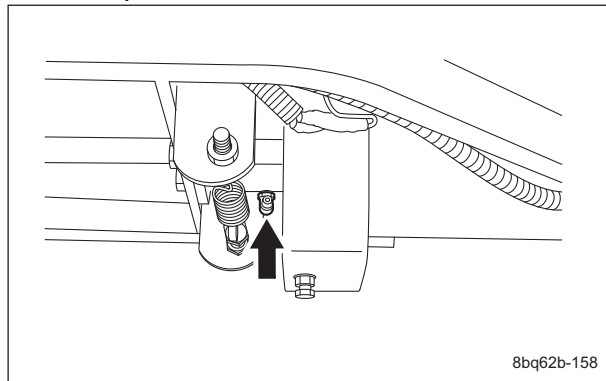

Greasing Points_009

8bq62b-158

7. Flexible wire bracket

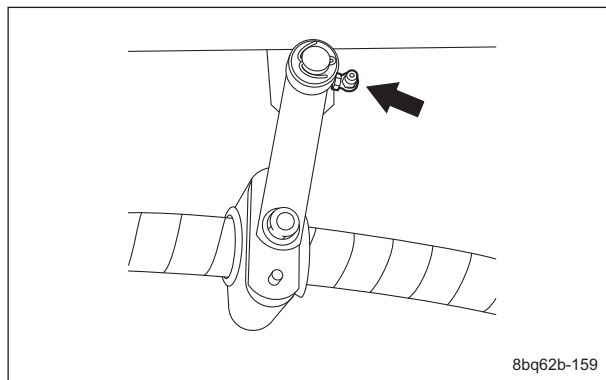

Greasing Points_010

8bq62b-159

8. Traveling pedal shaft fulcrum

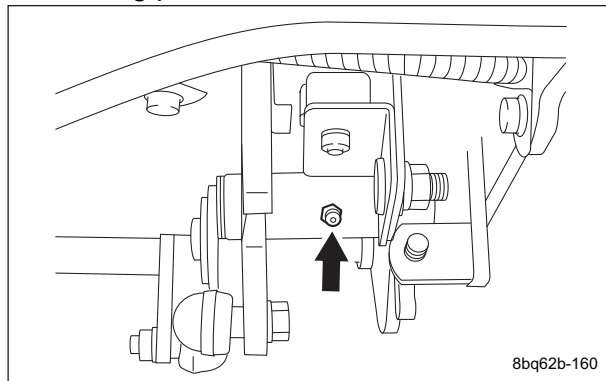

Greasing Points_011

8bq62b-160

9. Rear wheel brake lever shaft

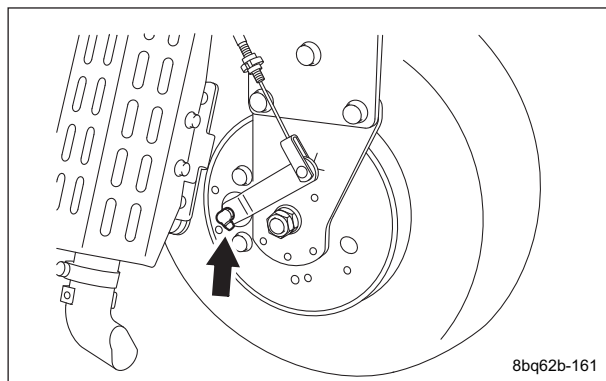

Greasing Points_012

8bq62b-161

Maintenance standards and maintenance

10. Flexible wire edge

There is one greasing point on each flexible wire.

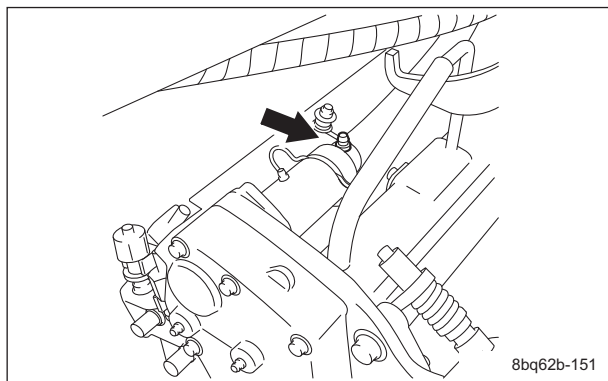

Greasing Points_013

11. Flexible wire

Use Moly speed grease No.2
Screw in the grease cup 360 degrees and add grease.

Central part
Add grease every 8 hours of operation.

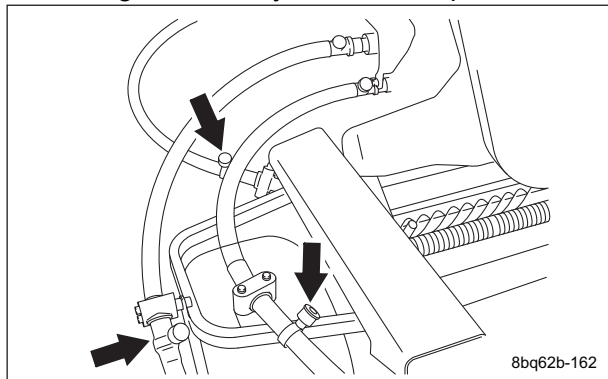

Greasing Points_014

Main body side

Add grease before operation.

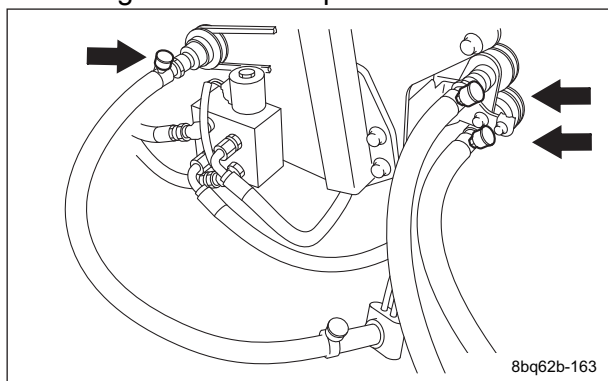

Greasing Points_015

Maintenance standards and maintenance

Maintenance.....	Page 4-2
Maintenance.....	Page 4-2
Specifications.....	Page 4-2
Specifications.....	Page 4-2
Hydraulic System Layout.....	Page 4-3
Flow of Hydraulic Oil.....	Page 4-5
General instructions.....	Page 4-8
Hydraulic hose.....	Page 4-8
Hydraulic fitting.....	Page 4-8
Towing.....	Page 4-13
Neutral.....	Page 4-13
Depressurization.....	Page 4-13
Hydraulic circuit failure.....	Page 4-13
Hydraulic circuit flow.....	Page 4-14
Traveling circuit.....	Page 4-14
Raise/lower circuit.....	Page 4-18
Steering circuit.....	Page 4-20
Special Tool.....	Page 4-22
List of Special Tools.....	Page 4-22
Measurement.....	Page 4-27
Note.....	Page 4-27
Traveling Circuit.....	Page 4-28
Up/Down circuit.....	Page 4-32
Steering Circuit.....	Page 4-34
Charge Circuit.....	Page 4-36
Adjustment.....	Page 4-37
Adjusting Mower Unit Up/Down Speed.....	Page 4-37
General inspection and repair.....	Page 4-37
Note.....	Page 4-37
Hydraulic hose, piping.....	Page 4-38
Hydraulic Oil.....	Page 4-38
Air bleeding.....	Page 4-39

Hydraulic system

Maintenance

Maintenance

This chapter describes primary checking and maintenance operations for the LM315GC hydraulic system.

For information on daily checks, maintenance and handling of the machine, please refer to the separate LM315GC Owner's Operating Manual and Parts Catalog.

To maintain the integrity of the hydraulic device, you must not overhaul the device for maintenance.

For those parts that must be repaired by the manufacturer, the overhaul procedure is not described in this manual. Request repairs for those parts from your dealer or Baroness.

Please note that our product warranty may be void if you overhaul the device.

Specifications

Specifications

HST	KYB PSV-16CHG-2		
	Piston pump	Displacement	0 - 16.4 cm ³ /rev (1.00 in ³ /rev)
		High-pressure relief set pressure	20.6 MPa (2,987.7 psi)
	Charge pump	Displacement	4.9 cm ³ /rev (0.30 in ³ /rev)
		Relief set pressure	0.58 MPa (84.1 psi)
Gear pump	Displacement	5.45 cm ³ /rev (0.33 in ³ /rev)	
Wheel motor	EATON orbit motor		
	Front wheel motor 2-125BS4V	Displacement	123 cm ³ /rev (7.51 in ³ /rev)
	Rear wheel motor 2-160BS4S	Displacement	158 cm ³ /rev (9.64 in ³ /rev)
Steering control unit	EATON RV074 orbitrol	Displacement	74.0 cm ³ /rev (4.52 in ³ /rev)
		Relief set pressure	4.4 MPa (638.1 psi)
Valve module		Relief set pressure	5.0 MPa (725.2 psi)
Hydraulic tank capacity (oil gauge center)		16.0 L (4.23 US gallons)	
Hydraulic line filter (cartridge type)		10 µm	
Hydraulic oil		Shell Tellus S2M46 or equivalent (ISO VG46)	

Hydraulic System Layout

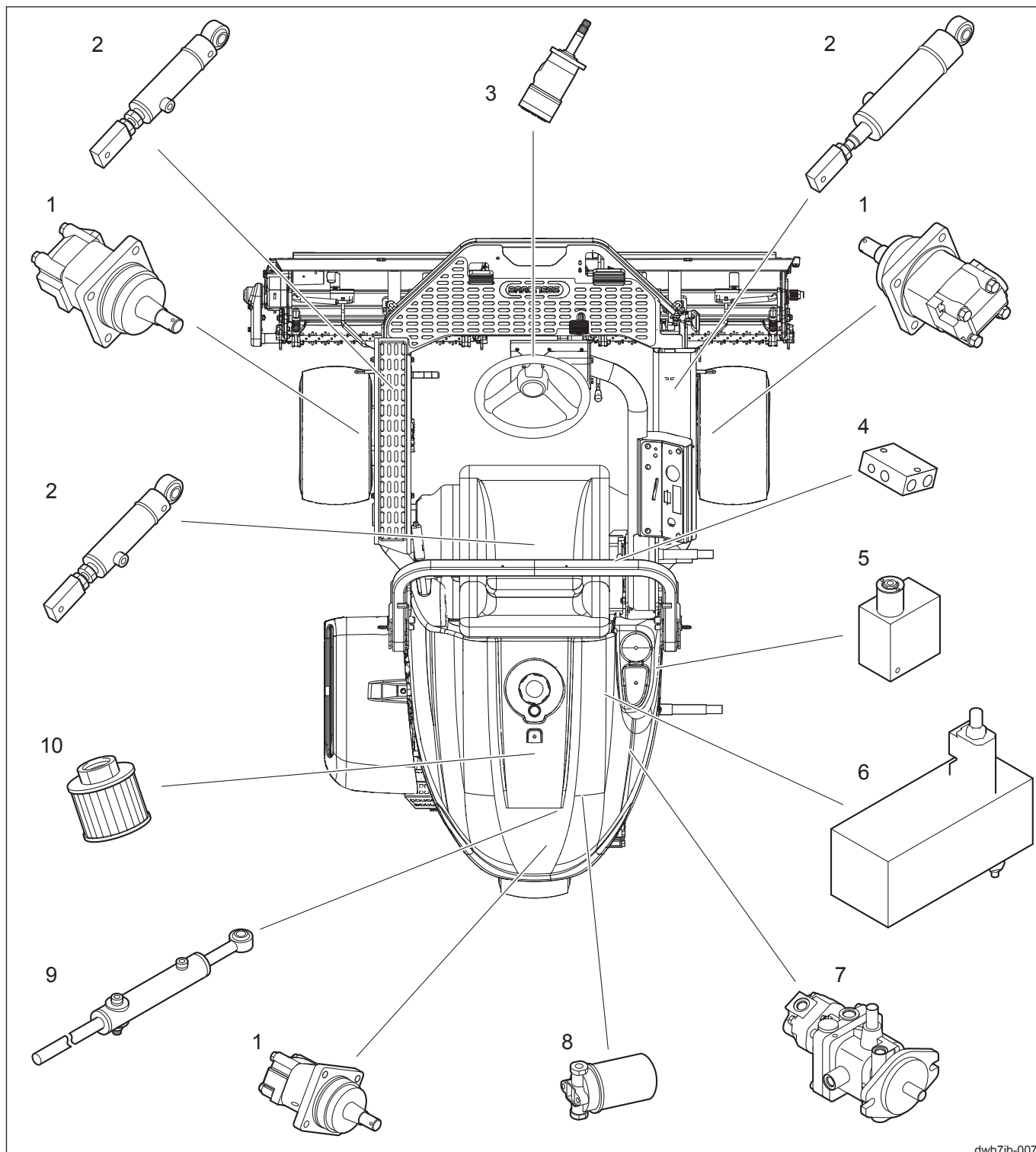

dwb7jb-007

Hydraulic System Layout_001

1	Wheel motor	5	2WD/3WD Changeover Valve	9	Steering cylinder
2	Up/down cylinder	6	Valve module	10	Suction filter
3	Orbitrol	7	Piston pump		
4	Manifold valve	8	Oil filter		

Hydraulic system

1. Wheel motor
These convert the fluid energy from the piston pump to mechanical energy (rotary motion) in order to directly drive the machine.
These are located at each wheel.
2. Up/down cylinder
These convert the fluid energy from the piston pump to mechanical energy (reciprocating motion) in order to raise the mower units.
These are located near the mower arms.
3. Orbitrol
In a fully hydraulic power steering unit, switching of the internal valve depending on the rotational input from the steering wheel causes oil from the hydraulic pump to be fed to the steering cylinder. It is located at the steering wheel installation part.
4. Manifold valve
This has a path through which oil flows and a connection port outside.
It is located in front of the piston pump.
5. 2WD/3WD Changeover Valve
This controls the vehicle drive switching the passage of fluid energy from the piston pump to wheel motors at either three wheels or two wheels in parallel.
It is located in the center of the right side of the body.
6. Valve module
This controls the up/down motions of the mower units switching the passage of fluid energy from the piston pump to the up/down side of the up/down cylinder.
It is located to the right of the fuel tank.
7. Piston pump
This converts the mechanical energy of the engine to fluid energy by using the reciprocating motion of the piston.
It is located to the right of the center of the main body.
8. Oil filter
This removes dirt or dust in the outgoing fluid.
This fulfills an essential role since elements that could cause major problems may be circulated if there was no filter.
It is located to the right of the rear wheel.
9. Steering cylinder
According to the control valve that is activated depending on the steering operation, this changes the flow of the fluid from the hydraulic pump to steer the vehicle to the left or right.
It is located above the rear wheel.
10. Suction filter
Installed at the suction side of the pump, this fulfills the major role of preventing the oil from being contaminated with impurities.
This is located in the hydraulic tank.

Hydraulic system

■3WD

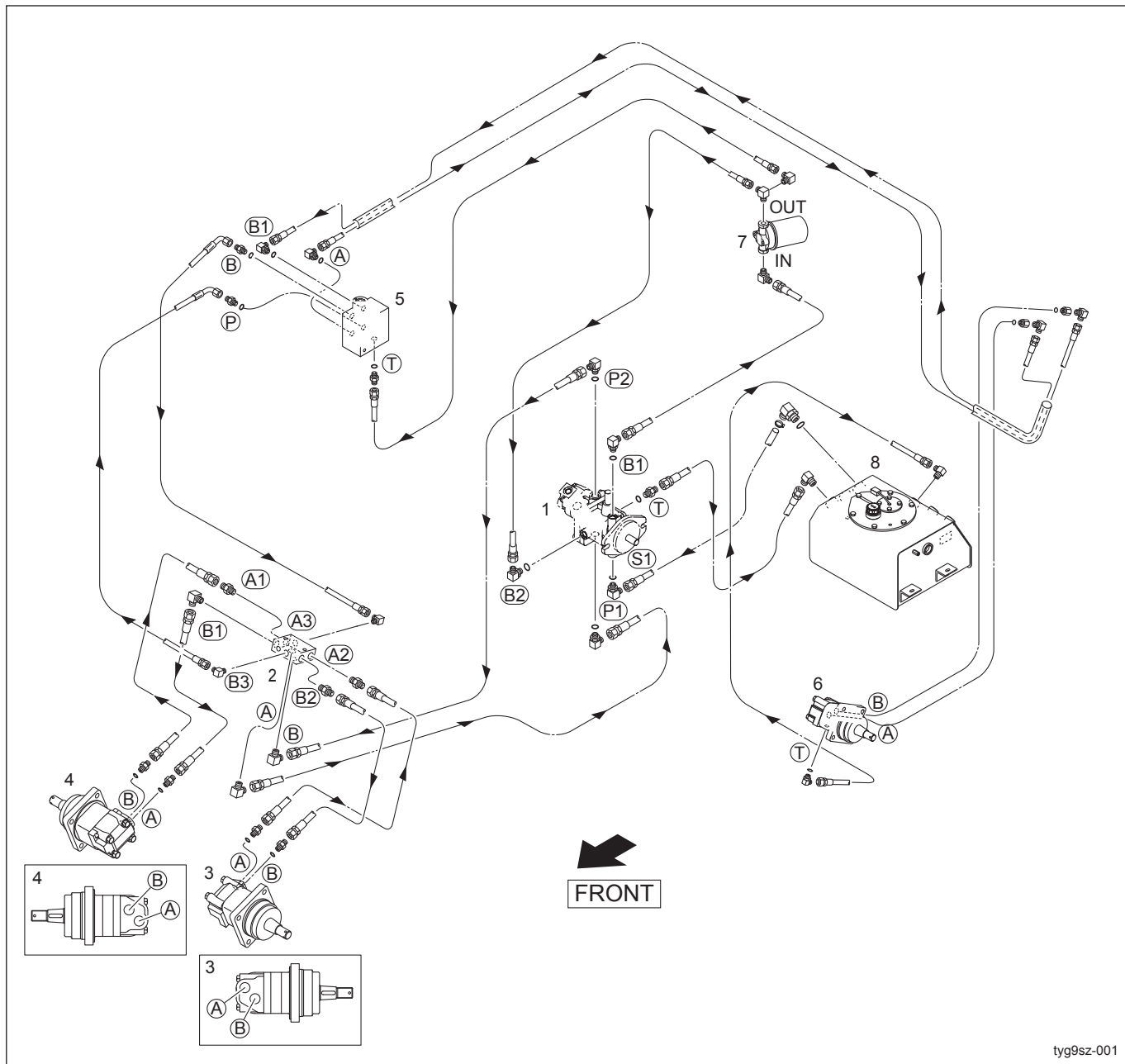

tyg9sz-001

3WD_001

→ shows flow of oil.

The flow of oil shows that for 3WD forward traveling.

Name in ○ above shows port name.

1	Piston pump	4	Right front wheel motor	7	Oil filter
2	Manifold valve	5	2WD/3WD Changeover Valve	8	Hydraulic tank
3	Left front wheel motor	6	Rear wheel motor		

Hydraulic system

Flow of Oil during Raising Mower Unit, with Power Steering Turning to Left

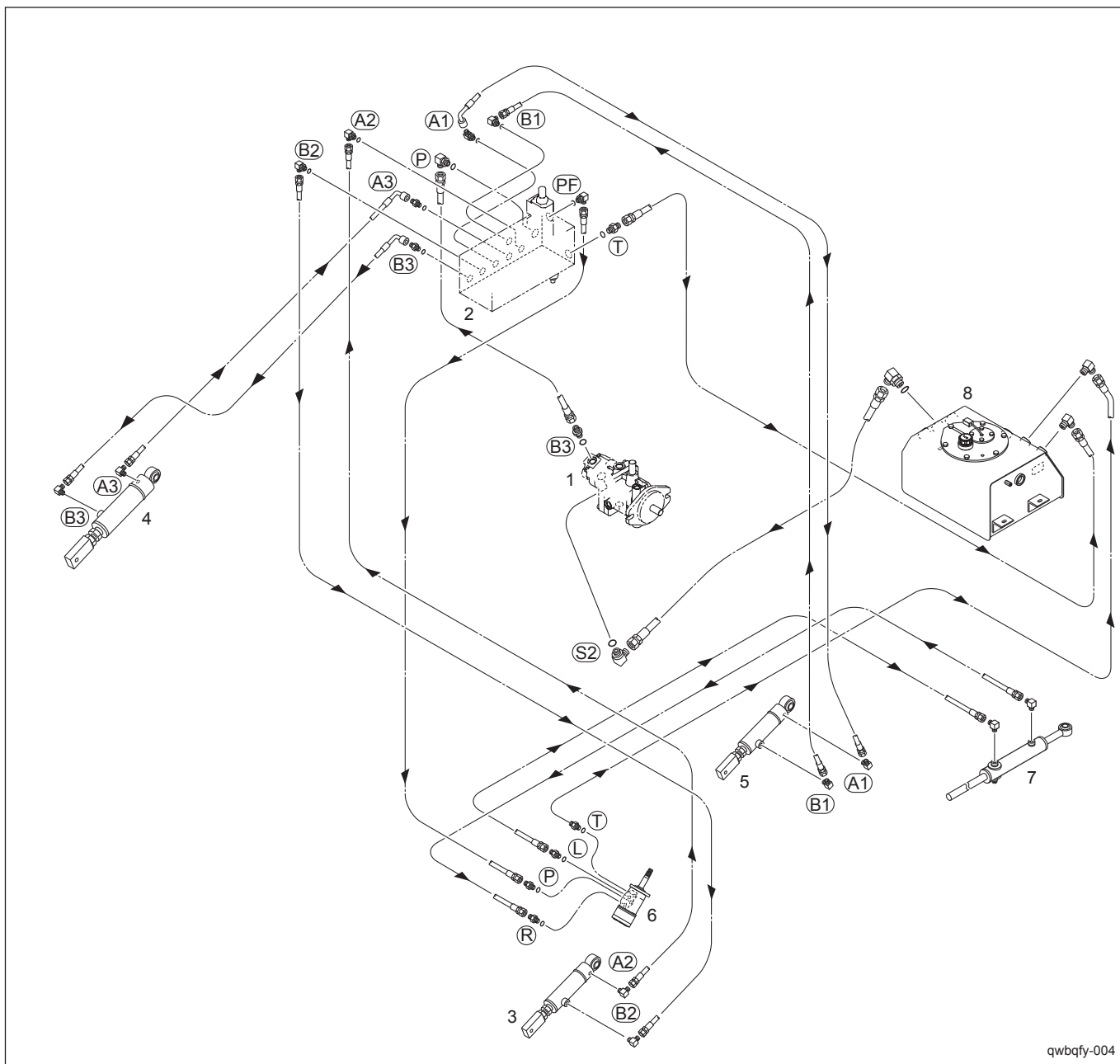

qwbqfy-004

Flow of Oil during Raising Mower Unit, with Power Steering Turning to Left_001

—→— shows flow of oil.

The flow of oil shows that for raising the mower unit, turning the power steering to left.

Name in ○ above shows port name.

1	Piston pump	4	Up/down cylinder of the right front mower unit	7	Steering cylinder
2	Valve module	5	Up/down cylinder of the rear mower unit	8	Hydraulic tank
3	Up/down cylinder of the left front mower unit	6	Orbitrol		

Hydraulic system

General instructions

Hydraulic hose

Hydraulic hoses are subjected to excessive load when weathered, exposed to the sun or chemicals, stored in a very hot storage environment, or handled roughly during operation or maintenance work. These factors may cause damage to hoses or facilitate their deterioration. Since a hydraulic hose is more sensitive to external conditions than other components, check it frequently for damage, deterioration or the like of.

When replacing the hydraulic hose, check that the hose is straight (not twisted before fitting). When replacing the hydraulic hose, use two wrenches. First, support the hose at a designated point with the first wrench. Next, fasten the hose swing nut to the fitting with the second wrench.

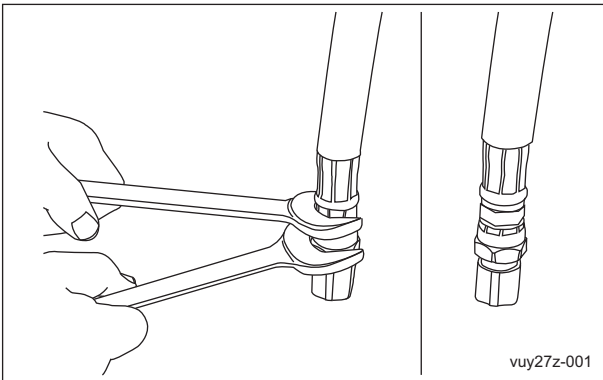

Hydraulic hose_001

Warning

Be sure to depressurize the hydraulic system before maintaining or repairing it.

Stop the engine, and lower the rake.

When checking for pinhole leakage of the hydraulic circuit or oil leakage of the nozzle, search for a leakage point using something like paper or cardboard, never with your bare hands. Be careful about high-pressure oil which may pierce your skin, resulting in physical injury.

Hydraulic fitting

Bite type tube fitting

Preliminary tightening (Preset)

1. Cut the tube at the designated length at a right angle.

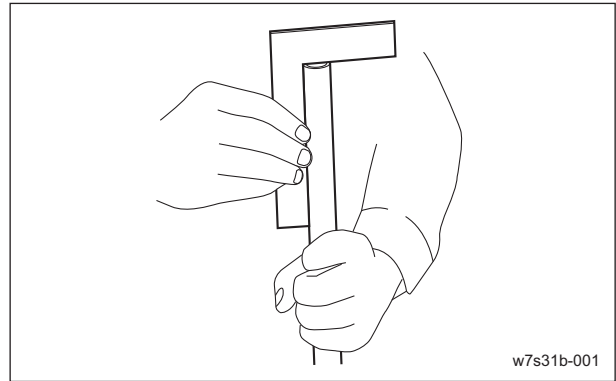

Bite type tube fitting_001

2. Remove burrs on the inside and outside of the tube with a file or the like of.

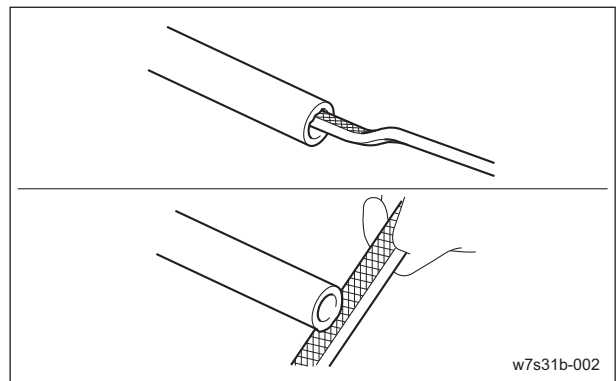

Bite type tube fitting_002

3. Insert the nut and sleeve into the tube. Note the direction of the sleeve.

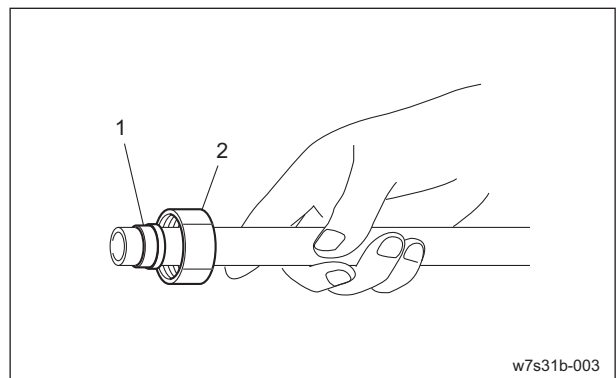

Bite type tube fitting_003

1	Sleeve
2	Nut

Hydraulic system

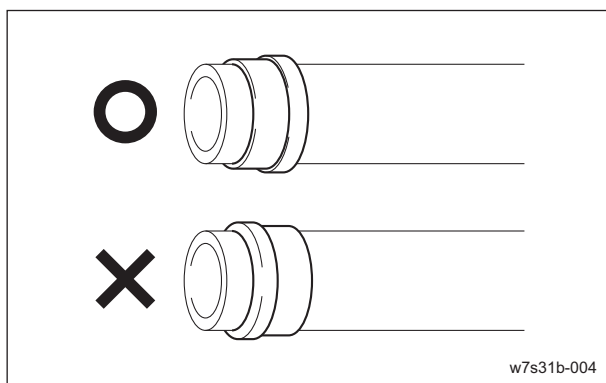

w7s31b-004

Bite type tube fitting_004

4. Fix the temporary tightening jig onto the vise and apply hydraulic oil to the threads, tapered part, and sleeve.

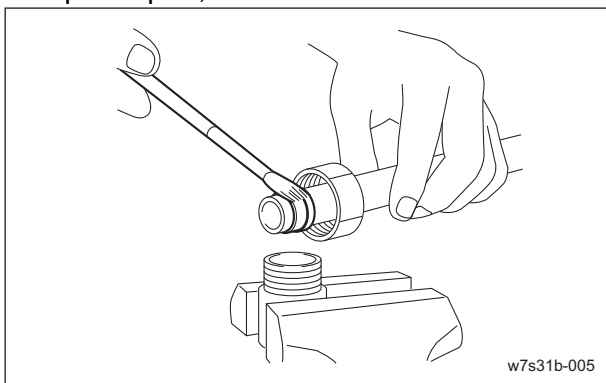

w7s31b-005

Bite type tube fitting_005

5. Put the tube end onto the hole bottom of the temporary tightening jig and tighten the nut slowly to the point where the tube can no longer be rotated by hand. This point is called the “zero point.”

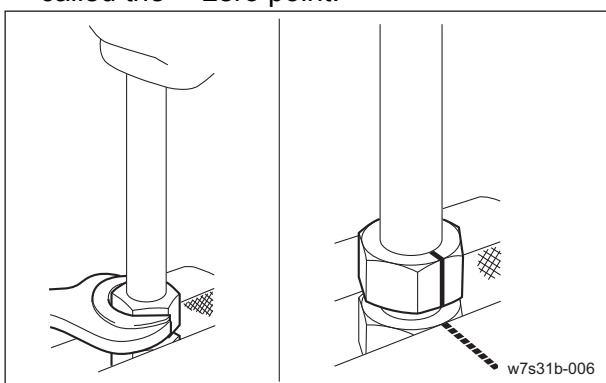

w7s31b-006

Bite type tube fitting_006

6. Matchmark the zero point and further tightening of 3/4 to one turn will cause the sleeve to bite into the tube.

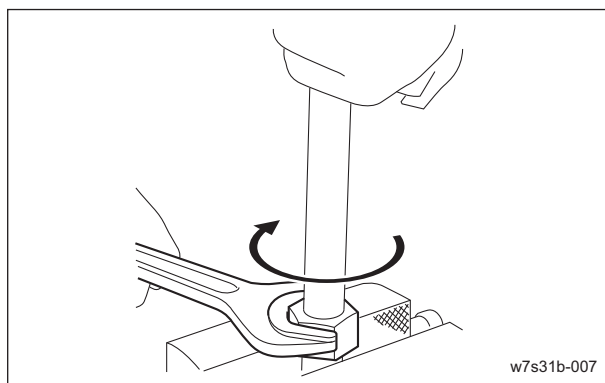

w7s31b-007

Bite type tube fitting_007

7. Fasten the nut and check that the sleeve end is a few mm apart from the tube end and the sleeve will not move in axial direction (it is allowed to move in the circumferential direction).

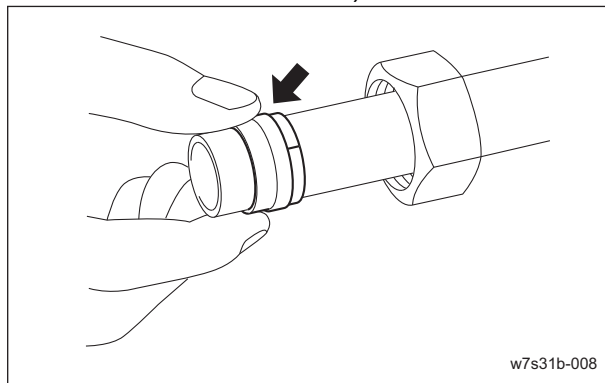

w7s31b-008

Bite type tube fitting_008

Final tightening (Reset)

- Fit the preliminary tightened tube onto the fitting body. Tighten with a spanner to the point where some resistance is suddenly felt, then further tighten with the nut for a 1/4 turn.

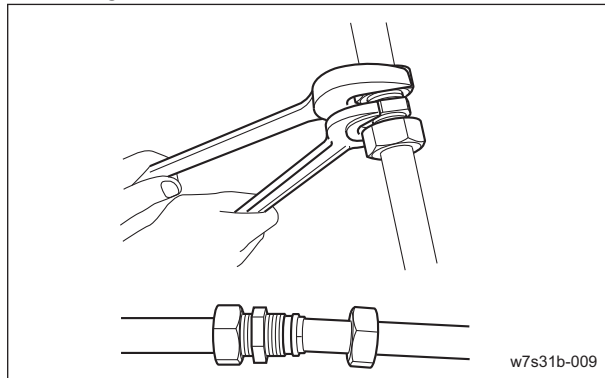

w7s31b-009

Bite type tube fitting_009

Hydraulic system

Note:

For direct tightening, use the fitting body to follow procedures 1 to 5 when using a temporary tightening jig, and set the zero point. Further tighten for 1/4 to 1 turn from the zero point.

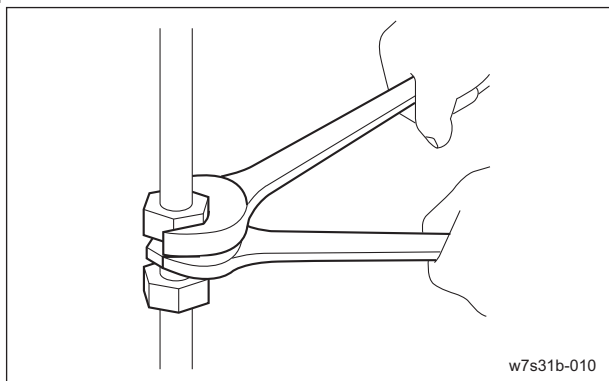

Bite type tube fitting_010

Reuse of piping

Bite type fitting can be reused if an inspection finds no flaw or other damage on the sleeve surface. Done properly, disassembly and retightening can be carried out up to five times or so.

Fitting with parallel pipe threads (O ring sealing system)

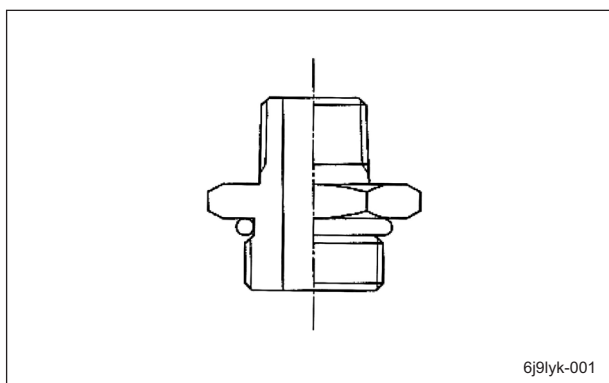

Fitting with parallel pipe threads (O ring sealing system)_001

1. Check to see if the O ring is properly fitted to the groove of the main body.
2. Check to see that the thread part, seat surface of O ring port and O ring are free from flaws or foreign matter.
3. Before fitting, apply hydraulic oil or grease to the O ring.
4. For fitting, screw in by hand till the main body touches the other side lightly, then tighten securely with a tool such as a spanner.

Adjustable Elbow

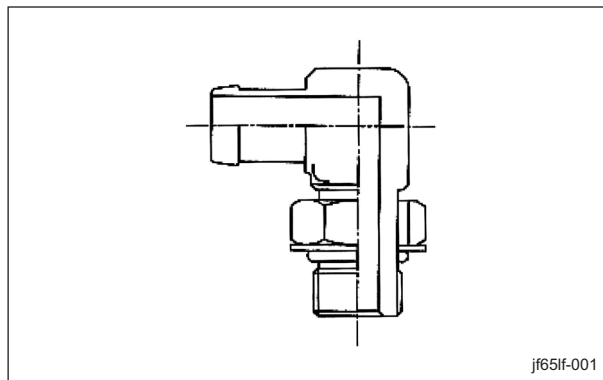

Adjustable Elbow_001

1. Make sure that the positions of the nut, washer, and O-ring are correct. If they are in the correct positions, the washer is pressed into the upper end of the groove of the main body.

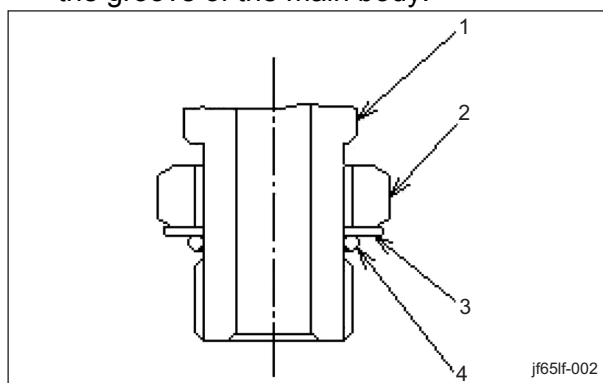

Adjustable Elbow_002

1	Main body
2	Lock nut
3	Washer
4	O-ring

Hydraulic system

2. Make sure that the thread portion, sheet surface of the O-ring port, and O-ring are not contaminated with foreign objects. Apply oil or grease to the sheet surface and O-ring before installation.

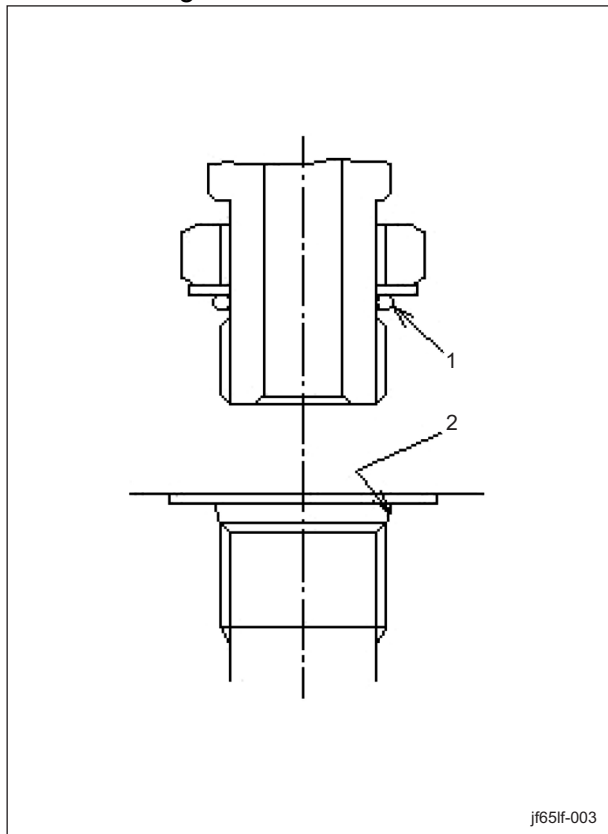

Adjustable Elbow_003

1	O-ring
2	Sheet surface

Caution

Be careful to never give the locknut more than one turns. If you give it more than one turn, the thread fit between the other side port and locknut becomes loose, which reduces the thread strength. If the washer goes too deeply into the other side port, the washer gets deformed, which leads to oil leakage. Rough installation makes the main body and nut overloaded, which leads to deformation. Be sure to observe the installation procedure.

3. To fit, screw the main body by hand till the washer face touches lightly, and turn from that position in the loosening direction to the setting position.

4. After fitting the opposite screw, tighten the lock nut while holding the main body with a spanner etc. to ensure that the setting position does not change.

Taper Pipe (PT) Thread Joint (Sealing Tape Method)

1. Make sure that the taper thread portion is not damaged or contaminated with foreign objects.

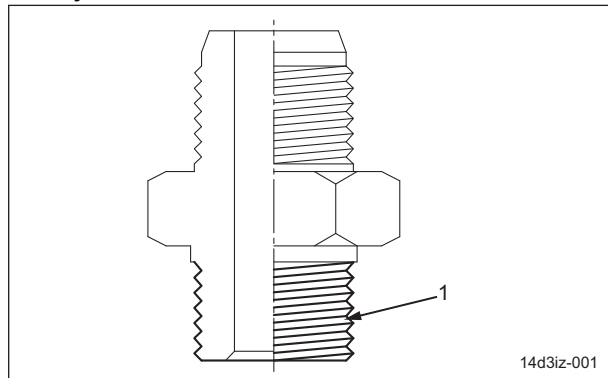

Taper Pipe (PT) Thread Joint (Sealing Tape Method)_001

1	Taper (PT) thread portion
---	---------------------------

Important

If a used taper pipe (PT) thread joint retains the residue of old sealing tape, using it again for assembly may cause machine problems or oil leakage.

Important

If you remove a taper thread joint, remove the sealing tape residue from the joint and connecting portion, so that the tape residue will not enter the hydraulic system.

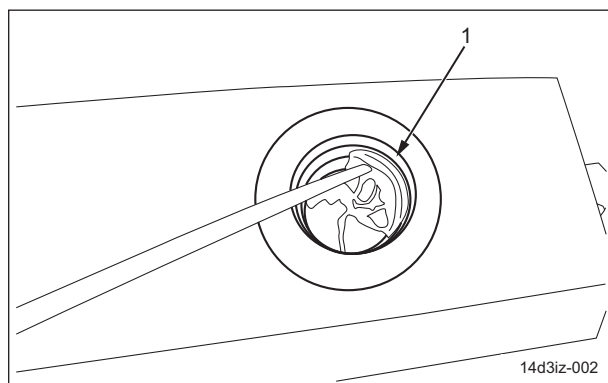

Taper Pipe (PT) Thread Joint (Sealing Tape Method)_002

1	Taper (PT) thread connecting portion
---	--------------------------------------

Hydraulic system

2. Before connecting the joint, wind sealing tape on the taper thread portion. (See "How to Use the Sealing Tape" (Page 4-12) .)

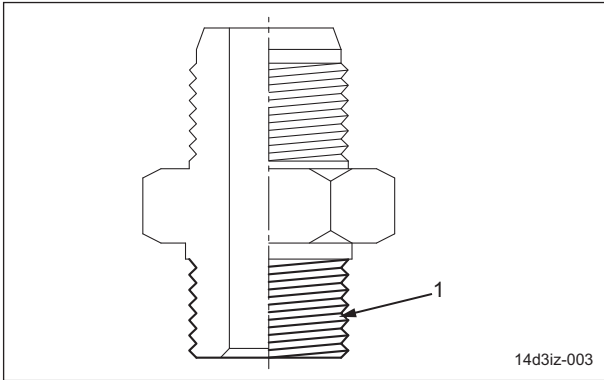

Taper Pipe (PT) Thread Joint (Sealing Tape Method)_003

1	Taper (PT) thread portion
---	---------------------------

How to Use the Sealing Tape

Important

Using the sealing tape with its end out of the edge face may cause a trouble of the machine due to its debris invading the hydraulic circuit.

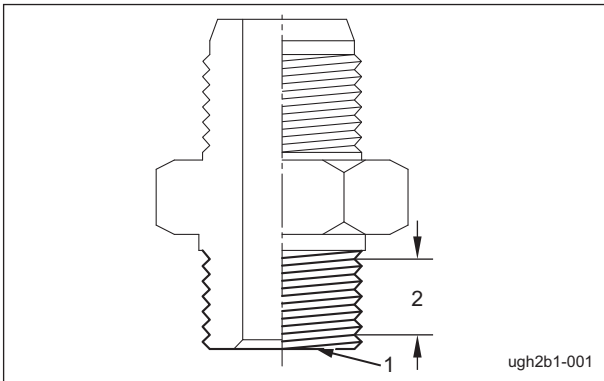

How to Use the Sealing Tape_001

1	Edge face
2	Sealing area

Important

Loosening again the taper thread joint which has been tightened may reduce its sealing effect to cause leakage of oil.

Note:

Pay attention to the following precautions when you use the sealing tape.

- Slightly pull the sealing tape (as tight as you can clearly see the thread mark on the tape) while you wrap it and overlap a half of its width to the previous round.

- Wrap it in clockwise direction (direction to tighten the screw). Wrapping in the opposite direction may cause the tape to be easily peeled off.

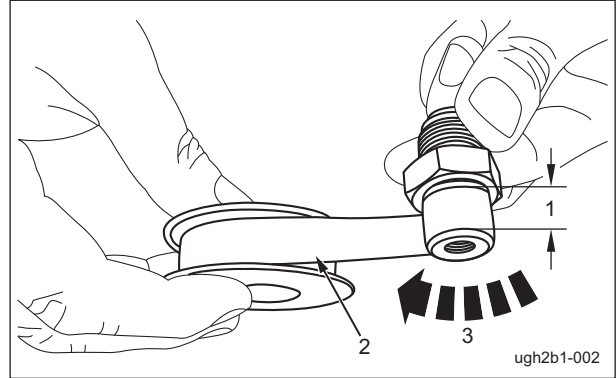

How to Use the Sealing Tape_002

1	Sealing area
2	Sealing tape
3	Clockwise direction

1. Wrap it in clockwise direction (direction to tighten the screw) about 1.5 to 2 turns from edge to root, starting from the point of 1 to 2 threads apart from the edge face of the thread.

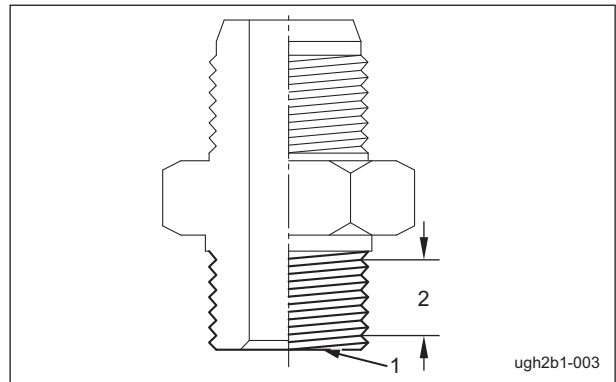

How to Use the Sealing Tape_003

1	Edge face
2	Sealing area

Towing

Important

Going over the limit of towing may lead to the failure of hydraulic equipment.
 Also, if the machine is towed at high speed, the wheel may cease its motion.
 Stop towing in case of wheel lock.
 Resume towing at low speed after the pressure has been stabilized.

In the event of loss of mobility due to engine trouble or the like of, movement is possible through towing or hand driving.
 Take the shortest route when towing or hand driving the machine.
 Transport the machine on a trailer if you have to transport it a long way.
 For the towing method, see the Owner' s manual.

Neutral

If the machine goes forward or in reverse without pressing on the forward/reverse pedals, the neutral is not working. Adjust accordingly.
 Refer to the Owner' s manual for adjustment of the neutral.

Depressurization

Be sure to depressurize the hydraulic system before inspecting or repairing it.
 When performing depressurization, move the machine to level surface.
 Apply the parking brake, and then lower the operating machine.
 Then, stop the engine and remove the key.
 To depressurize the hydraulic circuit, set the traveling pedal and all the drives of the operating machine to the neutral position.
 To depressurize the steering circuit, turn the steering wheel side to side.

Hydraulic circuit failure

The hydraulic traveling circuit of this equipment is made up of a closed circuit.
 In the event of failure of the hydraulic equipment of the hydraulic circuit, debris and contaminant from the faulty hydraulic equipment will circulate to every part of the circuit.

Since this contaminant causes damage to other hydraulic equipment, such debris and contaminant must be removed to prevent further failure of other hydraulic equipment.
 In the event that failure of hydraulic equipment is found in the hydraulic circuit, remove hydraulic hoses and piping of the whole hydraulic circuit and clean them well with kerosene.
 Drain all the hydraulic oil from hydraulic tank and hydraulic equipment other than the hydraulic hoses and piping and clean them well.
 We recommend to replace the hydraulic oil, hydraulic oil filter and defective hydraulic equipment with new ones.

Hydraulic system

■3WD

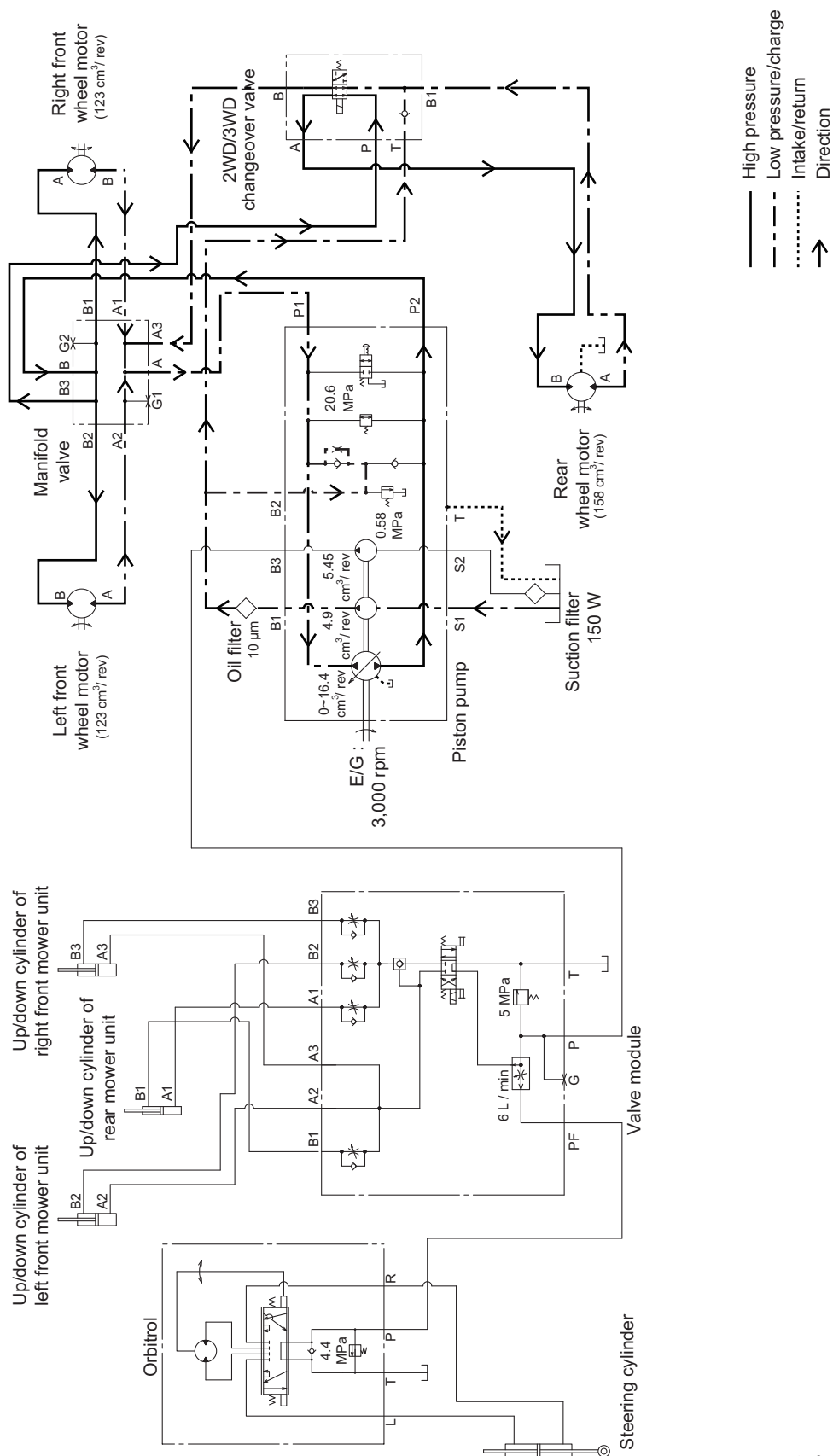

Hydraulic system

tyg9sz-006

3WD_001

Hydraulic system

Backward

■2WD

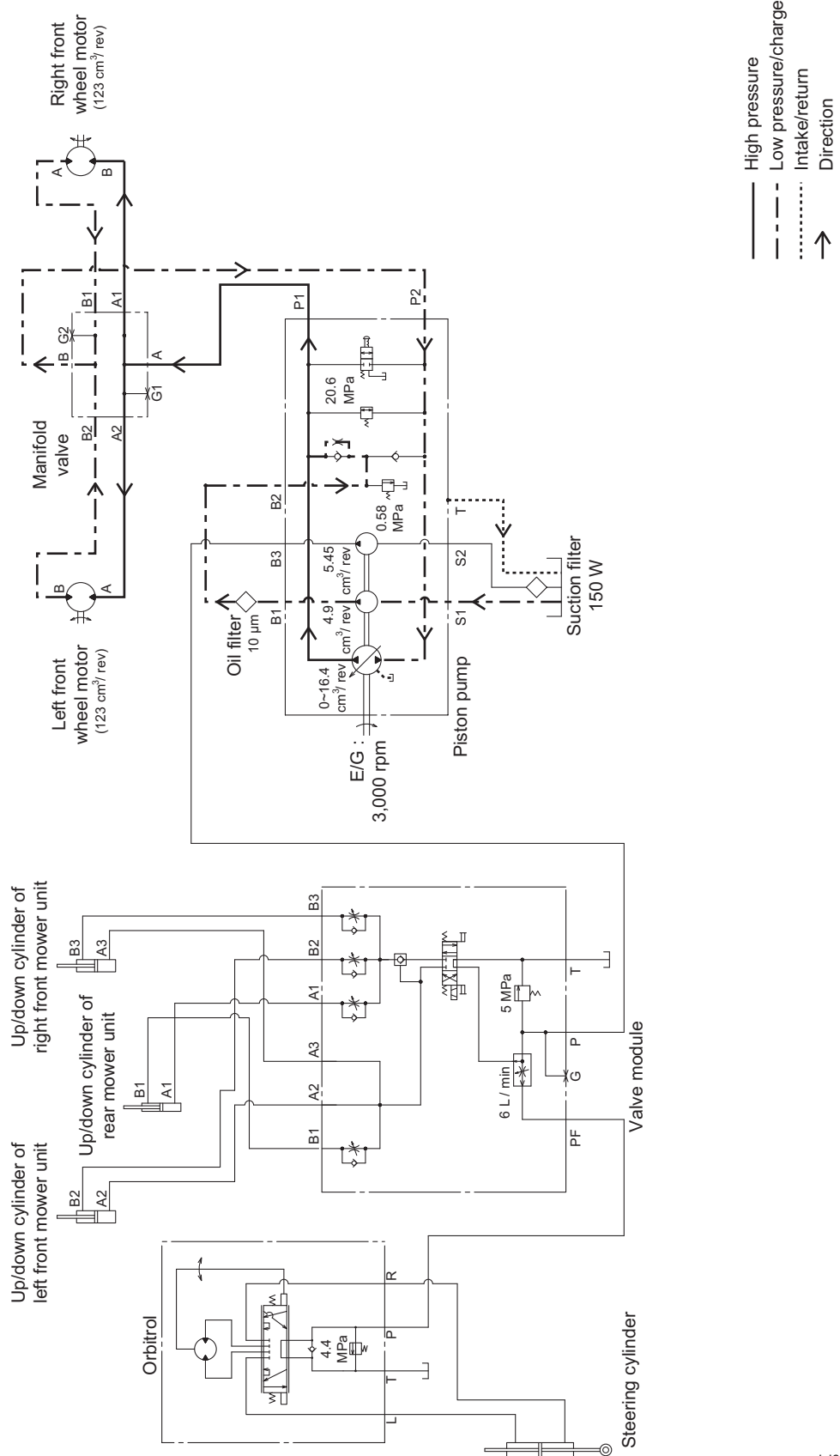

gslvj6-006

Hydraulic system

■3WD

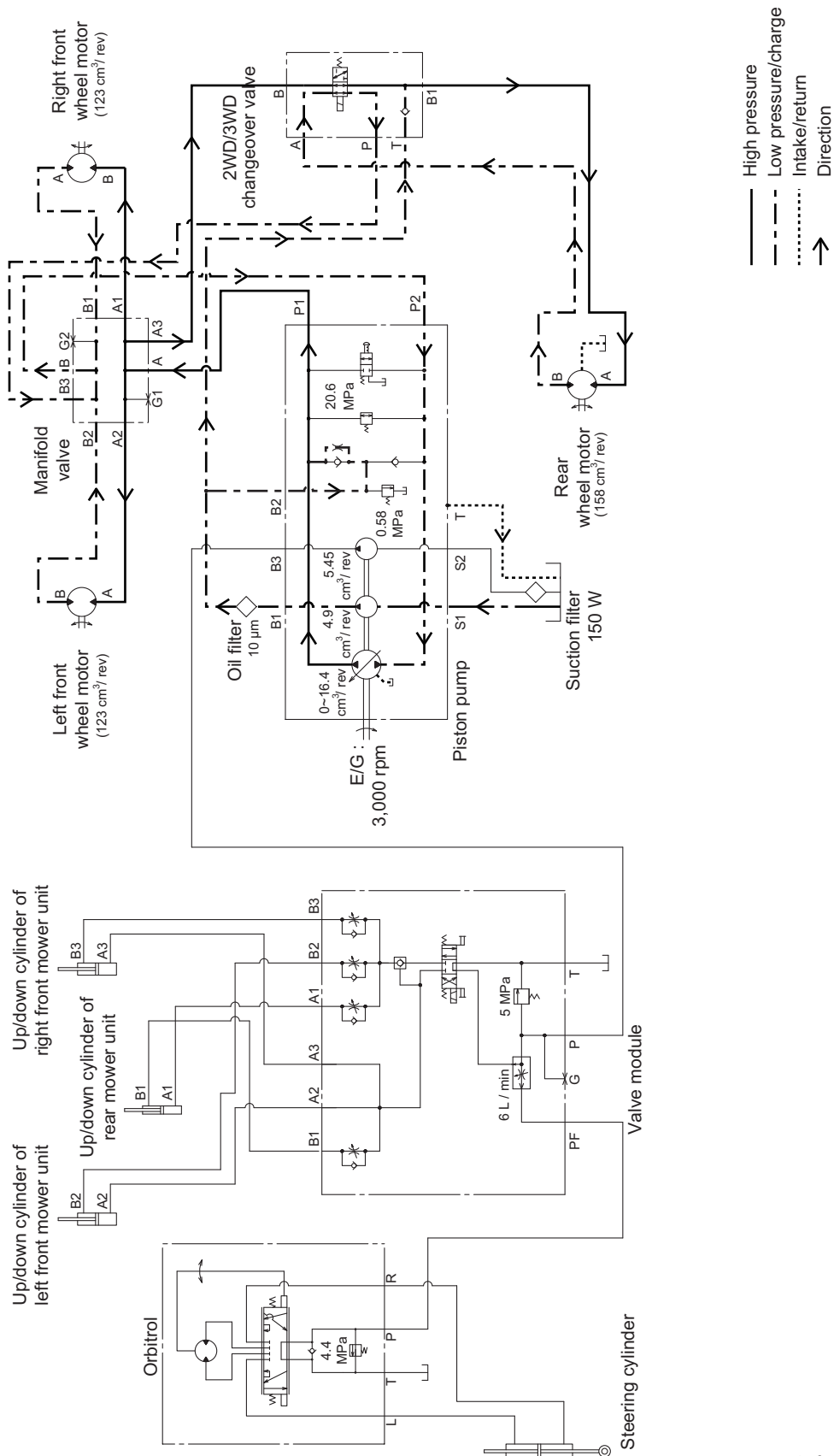

3WD_001

tyg9sz-007

Hydraulic system

Hydraulic system

Raise/lower circuit

Rising of up/down cylinder

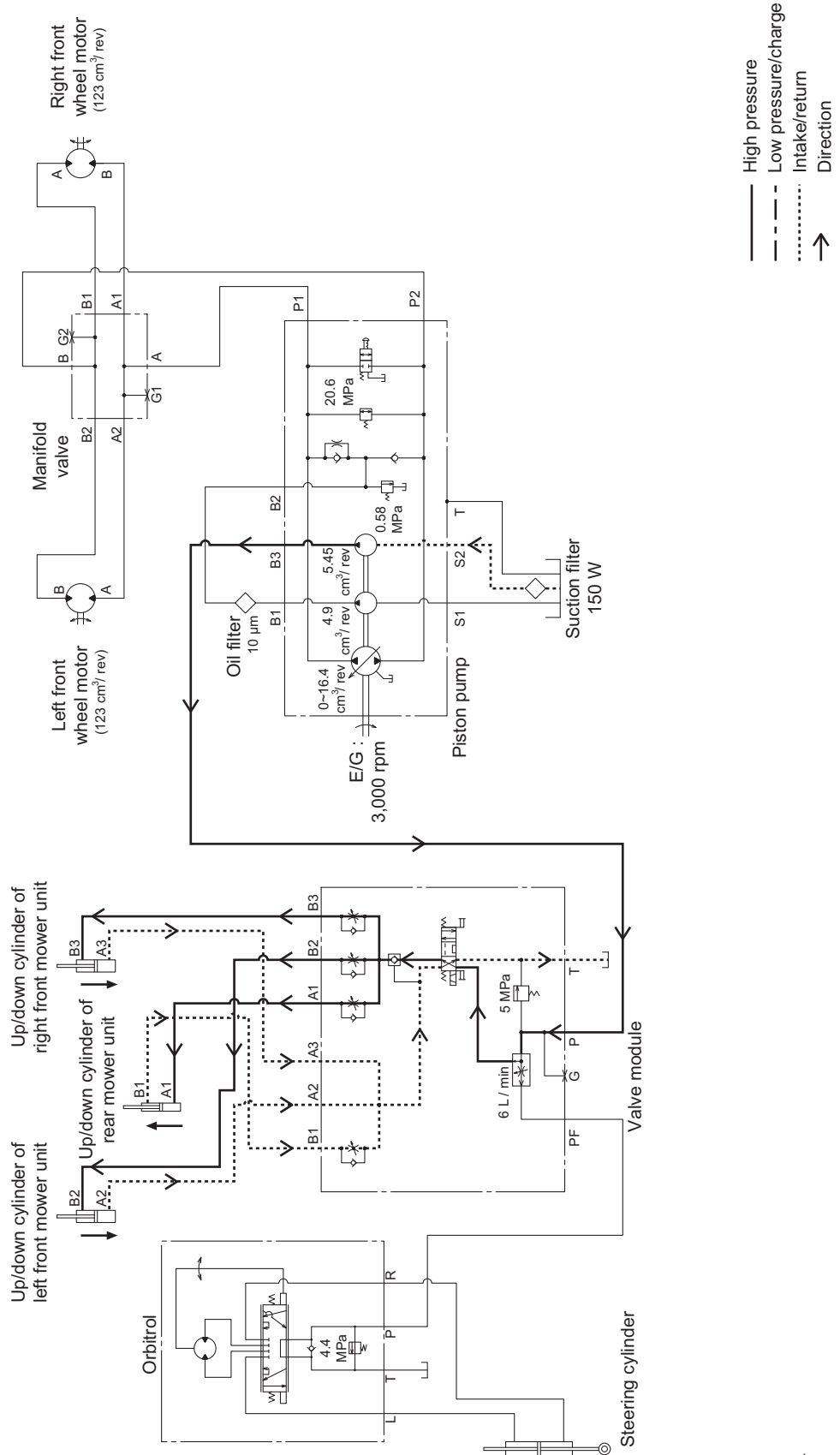

qhyyzc-009

Rising of up/down cylinder_001

Up/down cylinder lowering (operation)

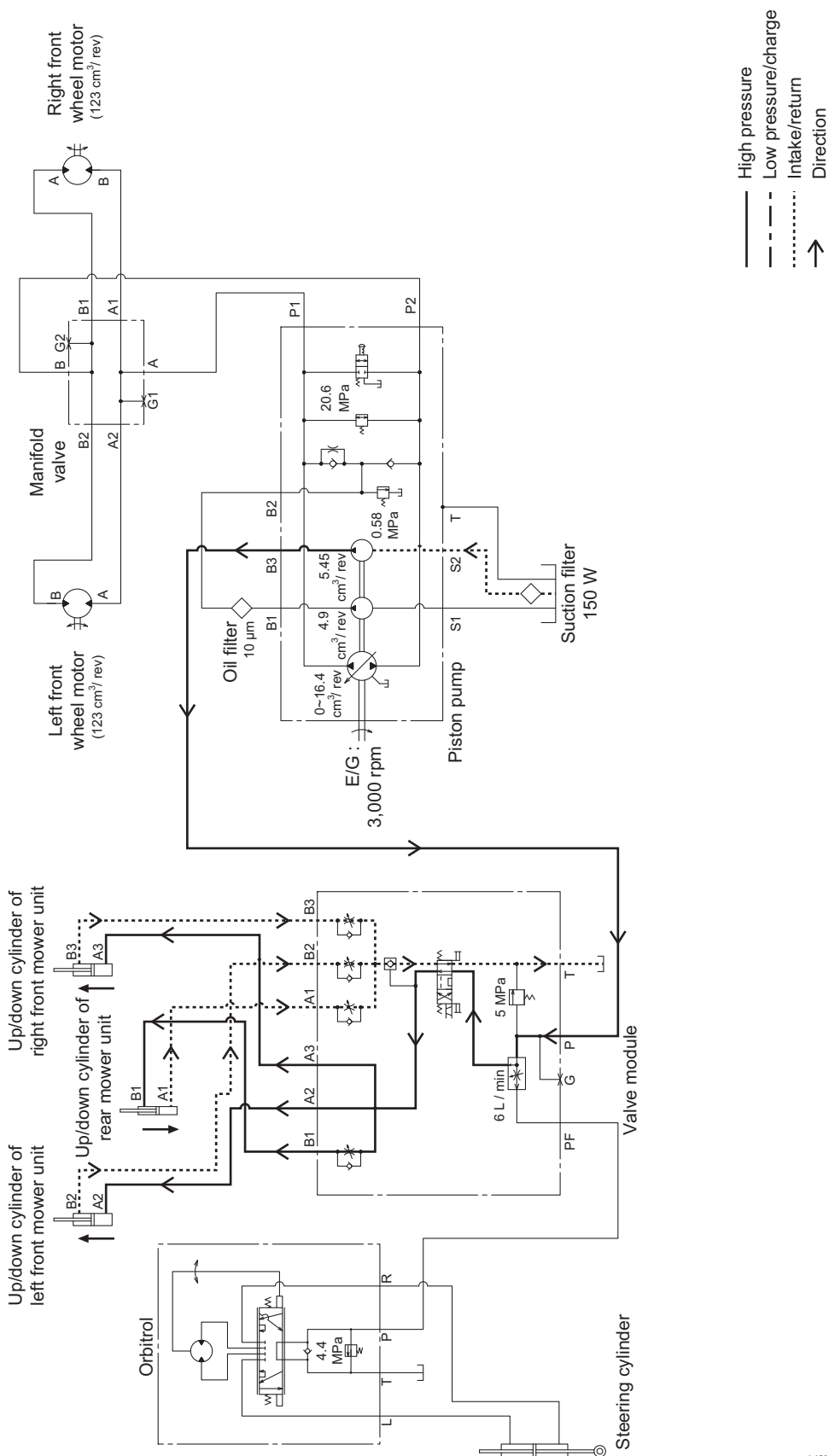

Hydraulic system

Up/down cylinder lowering (operation)_001

jtjfsj-009

Hydraulic system

Steering circuit

Steering cylinder counter-clockwise turning

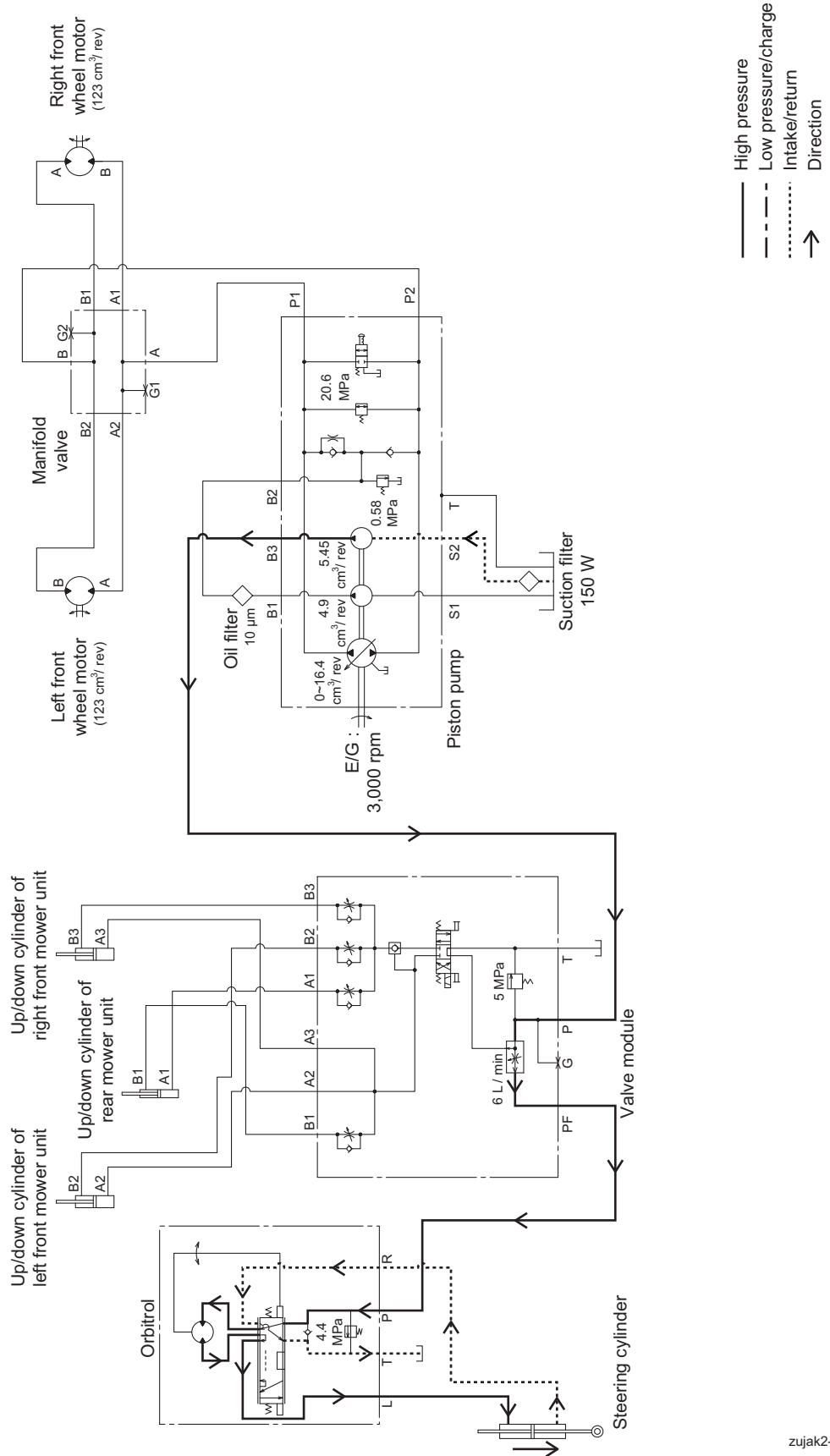

zujak2-003

Steering cylinder counter-clockwise turning_001

Hydraulic system

Steering cylinder clockwise turning

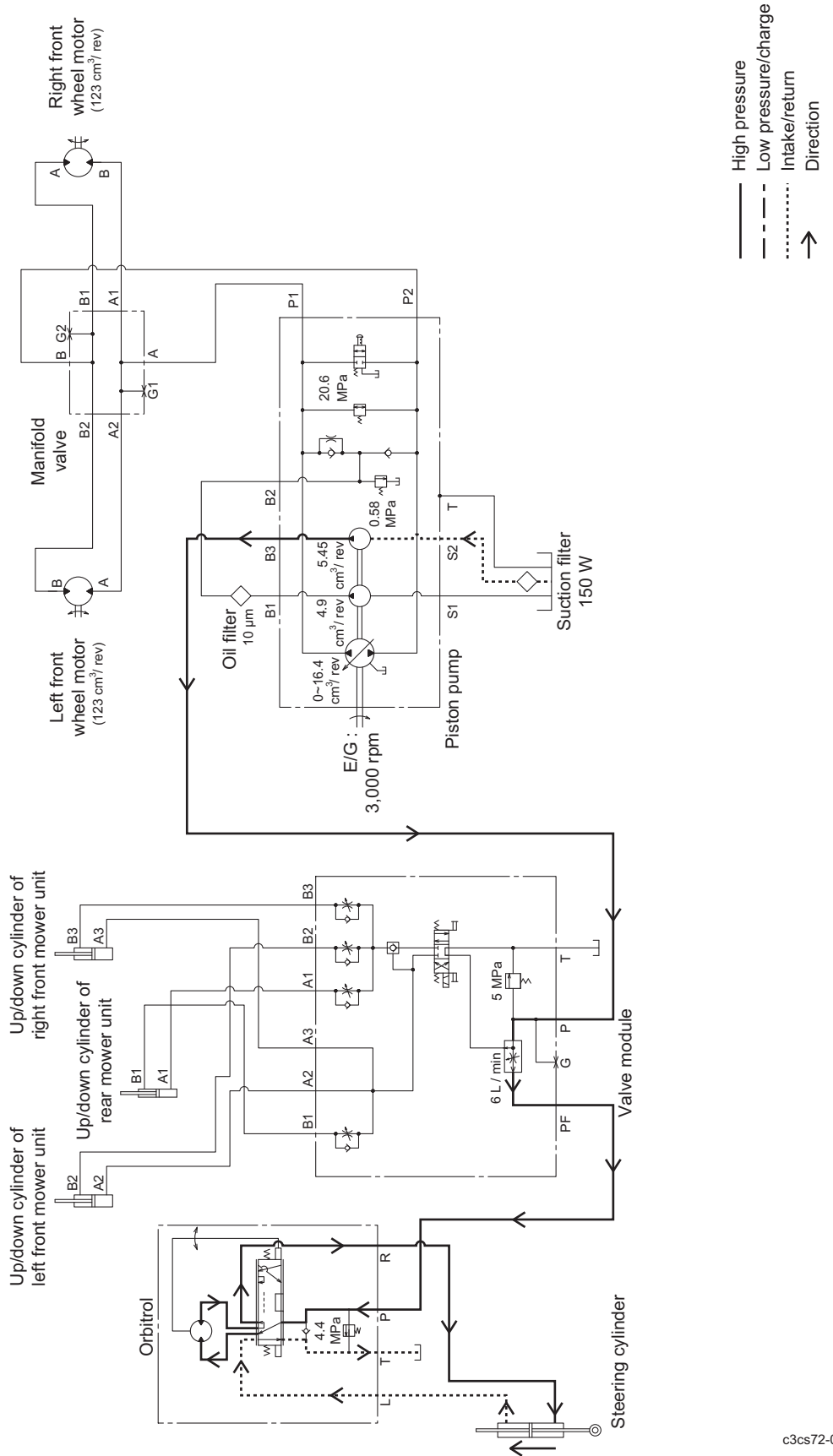

Steering cylinder clockwise turning_001

c3cs72-003

Hydraulic system

Special Tool

List of Special Tools

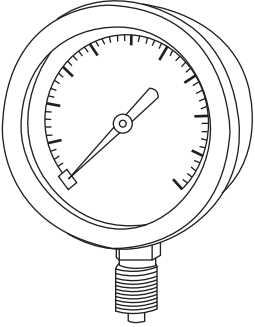
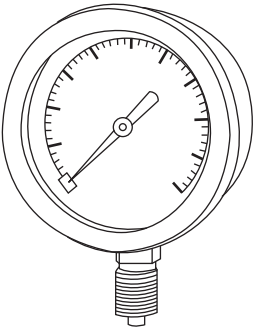
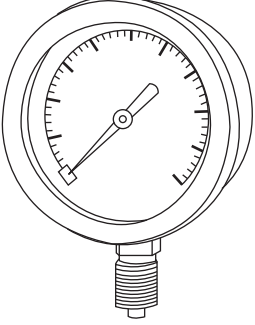
<p>Pressure gauge for high pressure measurements</p>  <p style="text-align: right; font-size: small;">vasdfi-004</p>	<p style="text-align: center;">K4701000010</p>	<p>Pressure: For the range of 0 - 35 MPa For the range of 0 - 5,076.40 psi For the range of 0 - 356.90 kgf/cm²</p> <p>Primarily used for measuring the pressure of high-pressure parts.</p>
<p>Pressure gauge for low pressure measurements</p>  <p style="text-align: right; font-size: small;">vasdfi-004</p>	<p style="text-align: center;">K4701000020</p>	<p>Pressure: For the range of 0 - 15 MPa For the range of 0 - 2,175.60 psi For the range of 0 - 152.96 kgf/cm²</p> <p>Primarily used for measuring the pressure of low-pressure parts.</p>
<p>Pressure gauge for extremely low pressure measurements</p>  <p style="text-align: right; font-size: small;">vasdfi-004</p>	<p style="text-align: center;">K4701000030</p>	<p>Pressure: For the range of 0 - 5 MPa For the range of 0 - 725.20 psi For the range of 0 - 50.99 kgf/cm²</p> <p>Primarily used to measure the pressure of extremely-low-pressure parts.</p>

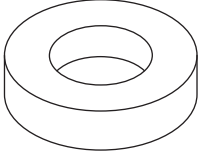
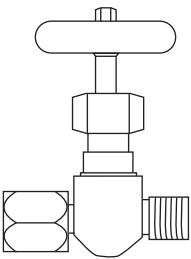
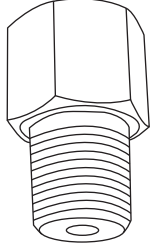
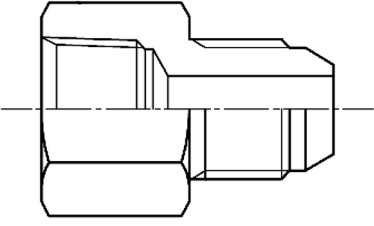
<p>Pressure gauge seal</p>  <p>vasdfi-005</p>	<p>K4701000050</p>	<p>Inserted between the pressure gauge and the gauge joint.</p>
<p>Gauge valve</p>  <p>vasdfi-016</p>	<p>K4701000060</p>	<p>Used to temporarily shut off the fluid to be measured during maintenance, check, or repair etc. of the pressure gauge.</p>
<p>Pressure gauge joint</p>  <p>vasdfi-006</p>	<p>K4701000040</p>	<p>Used as a joint for pressure pipes.</p>
<p>Female connector 1015-04</p>  <p>vasdfi-007</p>	<p>K3009000290-Y</p>	<p>Used as a connector to attach the hydraulic hose to the pressure gauge.</p>

Hydraulic system

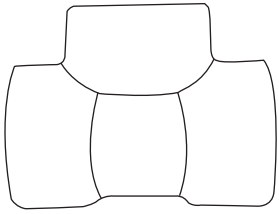
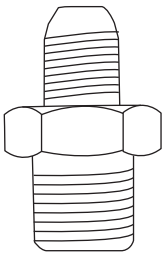
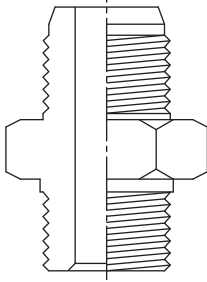
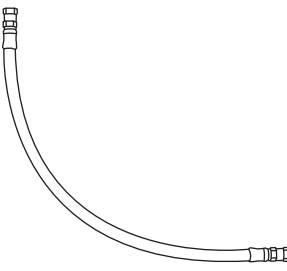
<p>Cast iron T-joint PT3/8 PF3/8</p>  <p style="text-align: right;">vasdfi-013</p>	<p>K3024000042-Y</p>	<p>Used to insert the pressure gauge between the hydraulic hoses.</p>
<p>Special adapter PF1/4 PT3/8</p>  <p style="text-align: right;">vasdfi-015</p>	<p>K3009000042-Y</p>	<p>Used as an elbow for the T-joint during pressure measurements.</p>
<p>Adapter 1013-9</p>  <p style="text-align: right;">q9c6v6-008</p>	<p>K3000090002-Y</p>	<p>Two of these are used as an elbow for the T-joint during pressure measurements.</p>
<p>WP280-6 hose 1-600</p>  <p style="text-align: right;">vasdfi-008</p>	<p>K3107210600</p>	<p>High pressure measurement - Used as a hydraulic hose for pressure measurement of 0 - 27.5 MPa.</p>

Hydraulic system

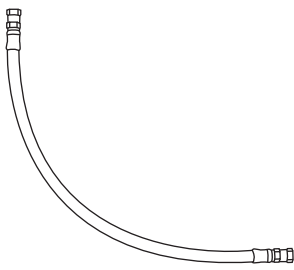
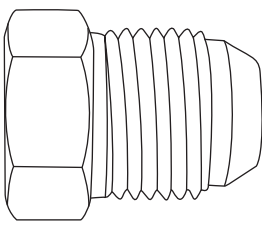
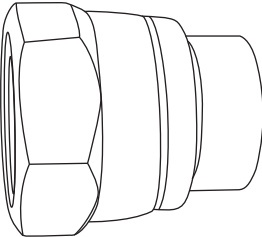
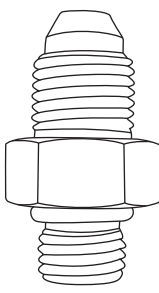
<p>WP210-9 hose 1-490</p>  <p>vasdfi-008</p>	<p>K3105310490</p>	<p>High pressure measurement - Used as a hydraulic hose for pressure of 0 - 20.5 MPa.</p>
<p>Screw cap (male) PF1/2</p>  <p>q9c6v6-001</p>	<p>K3008000542-Y</p>	<p>Used as a plug when the hydraulic hose is removed.</p>
<p>Screw cap (female) PF1/2</p>  <p>q9c6v6-002</p>	<p>K3008000502-Y</p>	<p>Used as a plug when the hydraulic hose is removed.</p>
<p>O-ring connector 1096-6</p>  <p>q9c6v6-005</p>	<p>K3008000342-Y</p>	<p>Used as a connector when installing the pressure gauge to the hydraulic measurement port.</p>

Hydraulic system

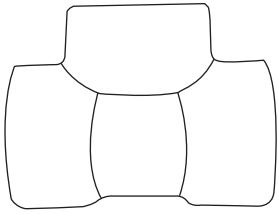
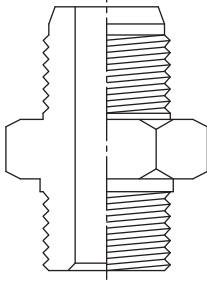
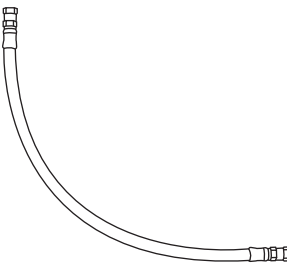
<p>T-joint TEFPT1/4</p>  <p>vasdfi-013</p>	<p>K3021040002-Y</p>	<p>Used to insert the pressure gauge between the hydraulic hoses.</p>
<p>Adapter 1013-6</p>  <p>q9c6v6-008</p>	<p>K3000060002-Y</p>	<p>Used as an elbow for the T-joint during pressure measurements.</p>
<p>WP140-6 hose 1-480</p>  <p>vasdfi-008</p>	<p>K3103210480</p>	<p>Low pressure measurement - Used as a hydraulic hose for pressure measurement of 0 - 14.0 MPa.</p>

Hydraulic system

Measurement

Note

The most effective way of solving problems in the hydraulic system is to use a measuring instrument such as a pressure gauge for measurement.

Before hydraulic measurement

Important

Before concluding that the problem in the hydraulic system is caused by the hydraulic equipment, every part of the hydraulic system must be checked for issues related to oil fill, oil filter, loosening of fasteners, lack of adjustment and so on.

Note on hydraulic measurement

Warning

As mentioned in the testing procedure, the use of a pressure gauge not meeting the pressure measurement standard may result in damage to the pressure gauge or leakage of high-pressure oil. Be extremely careful with high-pressure oil as it may pierce your skin, resulting in personal accidents.

Carry out hydraulic measurement with two or more persons. One person should be in the driver's seat to operate the machine and the other person should engage in measurement and recording.

Caution

When checking the hydraulic circuit for pinhole leaks or oil leakage from nozzles, never use your hands. Use items such as paper or corrugated cardboard to find leakage points. Be extremely careful with high-pressure oil as it may pierce your skin, resulting in personal accidents.

1. Always clean the machine before hydraulic measurement. Remember that the machine must always be kept clean for hydraulic measurement. Contamination may lead to clogging or breakage of the hydraulic circuit.
2. Review the measuring method before starting measurement.
3. Before measurement, check for maladjustment, clogging or breakage.

4. Warm up the hydraulic oil before starting hydraulic measurement.

Warning

Be sure to depressurize the hydraulic system before inspecting or repairing it.

5. When hydraulic equipment is removed, cap or plug it to prevent contamination of the hydraulic system.
6. When using a measuring instrument such as a pressure gauge, connect the in/out hoses correctly. Never connect the other way round to prevent breakage of the hydraulic system and measuring instrument.
7. Screw in the hydraulic fitting by hand till it touches the other side lightly, then fasten it with a wrench.
8. Fit hoses and measuring instruments in such a way as to avoid contact with the driving part of the machine.
9. After connecting a measuring instrument, check the amount of oil in the hydraulic tank.
10. Check to see that the engine is in good condition. Carry out hydraulic measurement with the engine running at maximum speed.
11. In case there is any problem in the traveling circuit, carry out the following measurement.
 - [1] Charge relief valve pressure
 - [2] Traveling relieve valve pressure
12. In case there is any problem in the raise/lower or steering circuit, carry out the following inspection.
 - [1] Relief valve pressure
 - [2] Oil leakage inside the hydraulic cylinder

Hydraulic system

Traveling Circuit

Forward

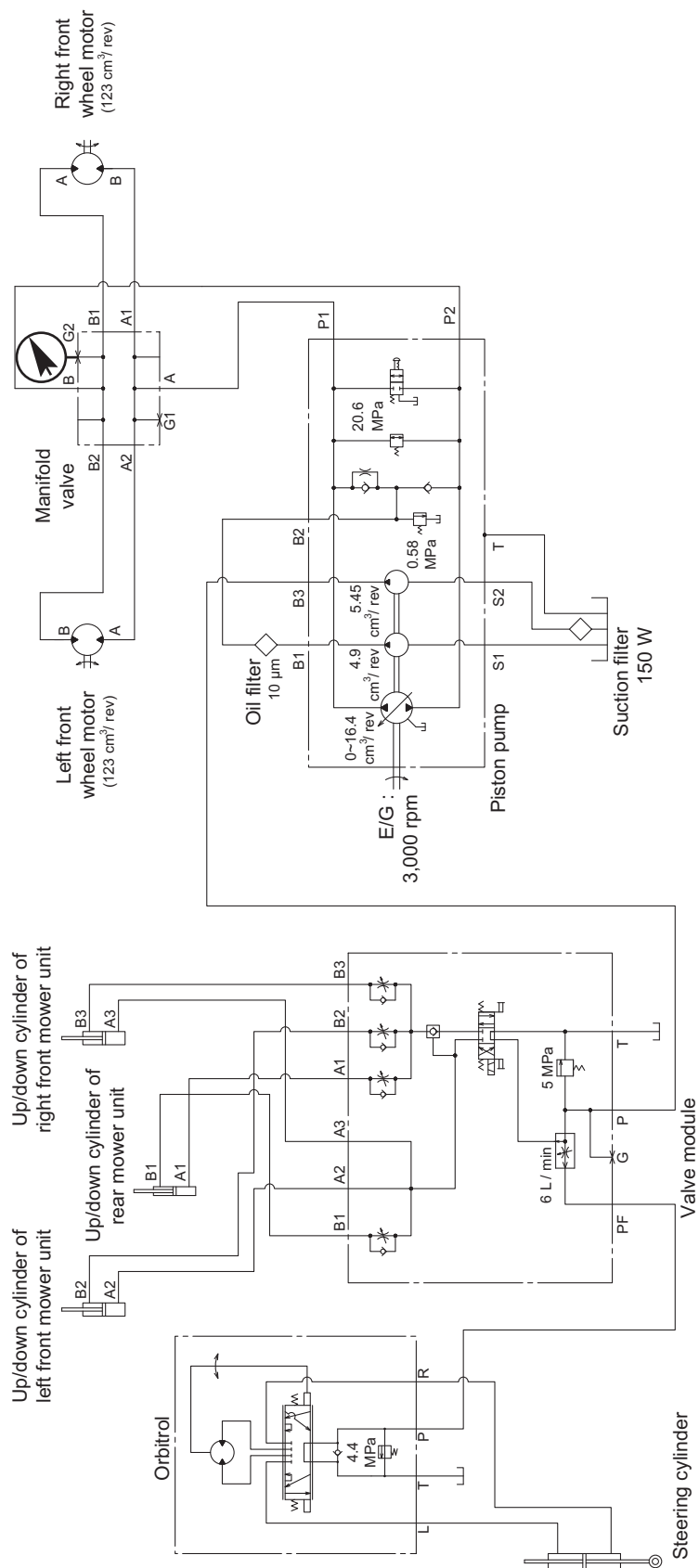

Hydraulic system

Caution

Before starting pressure measurement, make sure that there is no people around the machine.

1. The forward side measuring port connector is located in front of the manifold valve. Remove the screw cap of forward side measuring port connector.

Caution

Use a pressure gauge and hydraulic hose which can bear 25 MPa (3,625.8 psi) or more.

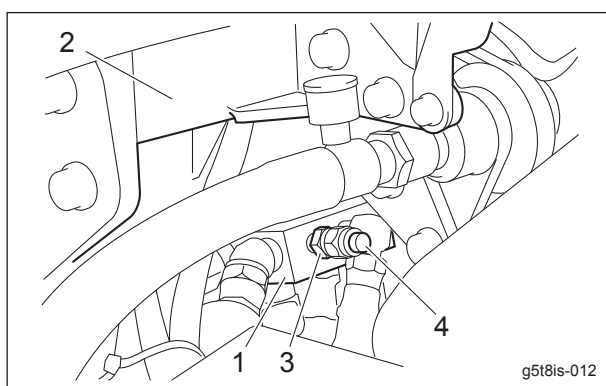

Forward_002

1	Manifold valve
2	Frame
3	Forward side measuring port connector
4	Screw cap

2. Attach the pressure gauge for high pressure measurements on the forward side measuring port connector.

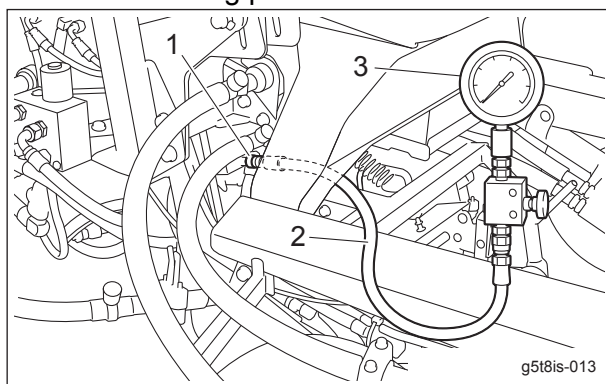

Forward_003

1	Forward side measuring port connector
2	Hydraulic hose
3	Pressure gauge for high pressure measurements

3. Use a shrink etc. to apply resistance on the rear hook so that the machine does not move forward.

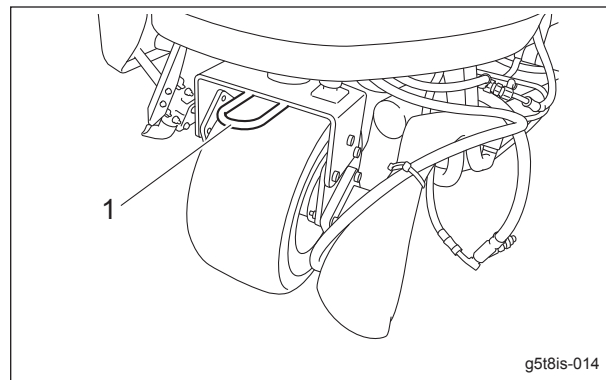

Forward_004

1	Rear hook
---	-----------

4. Make sure that the parking brake is applied.
5. Start the engine, and rev it up to the maximum rpm.
6. Depress the forward pedal, and it is normal if the pressure becomes 20.6 MPa (2,987.7 psi) with the tires locked without slipping.

Hydraulic system

Backward

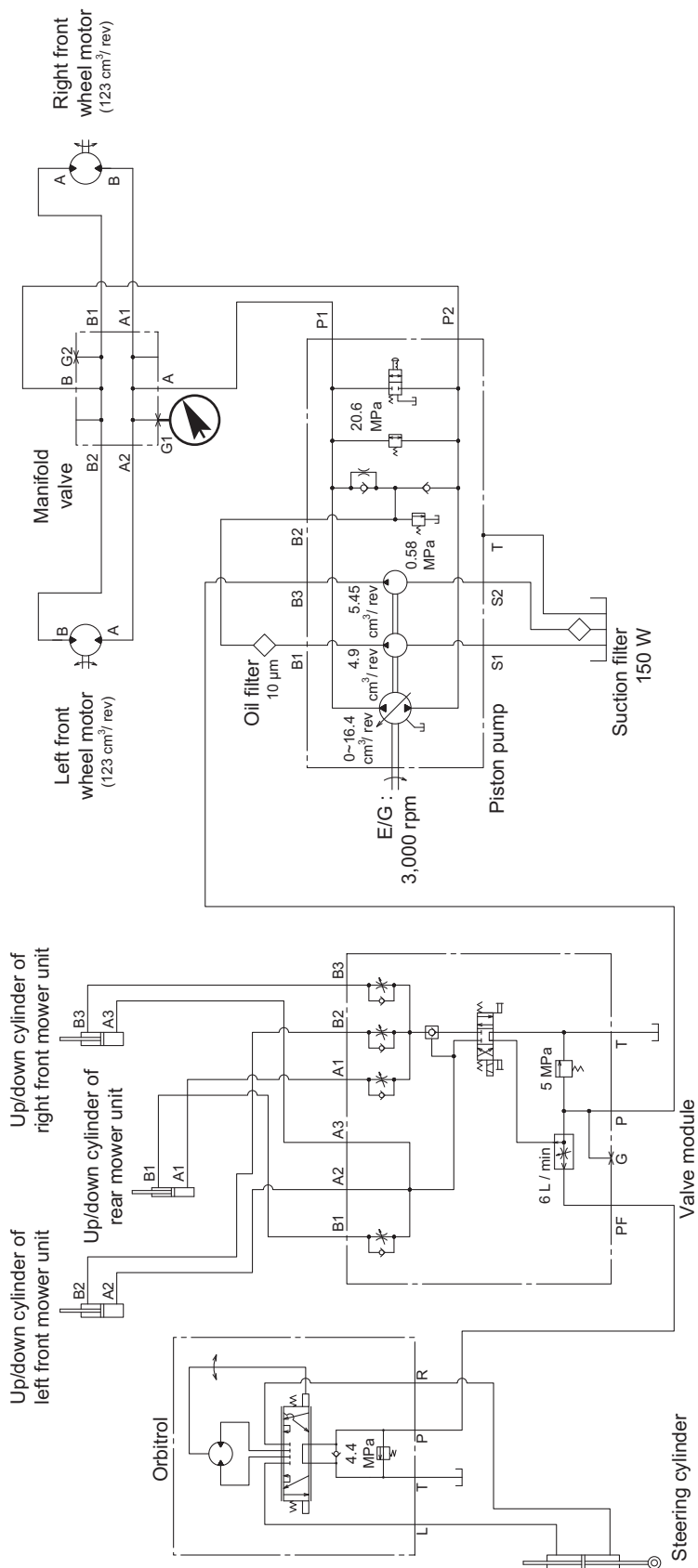

Reverse_001

7edlvx-015

Hydraulic system

Caution

Before starting pressure measurement, make sure that there is no people around the machine.

1. The reverse side measuring port connector is located at the rear part of the manifold valve.
Remove the screw cap of reverse side measuring port connector.

Caution

Use a pressure gauge and hydraulic hose which can bear 25 MPa (3,625.8 psi) or more.

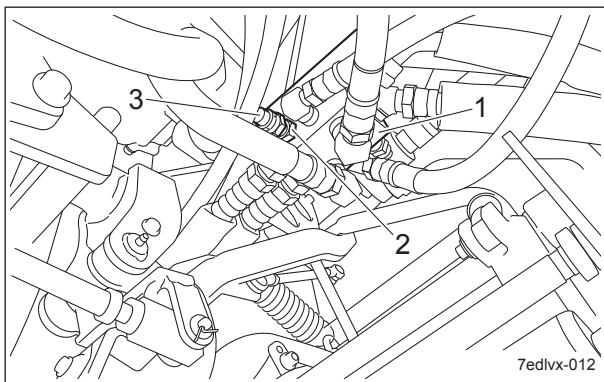

Reverse_002

1	Manifold valve
2	Reverse side measuring port connector
3	Screw cap

2. Attach the pressure gauge for high pressure measurements on the reverse side measuring port connector.

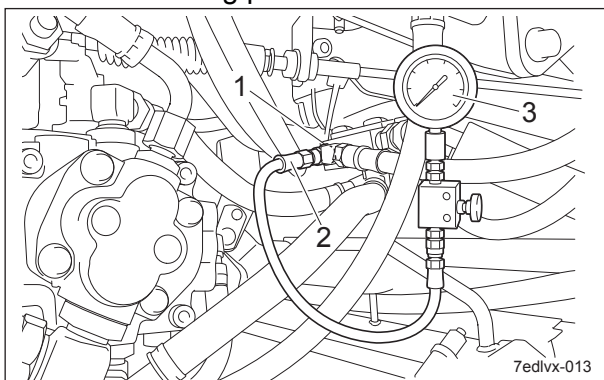

Reverse_003

1	Reverse side measuring port connector
2	Hydraulic hose
3	Pressure gauge for high pressure measurements

3. Use a shrink etc. to apply resistance on the front hook so that the machine does not move backward.

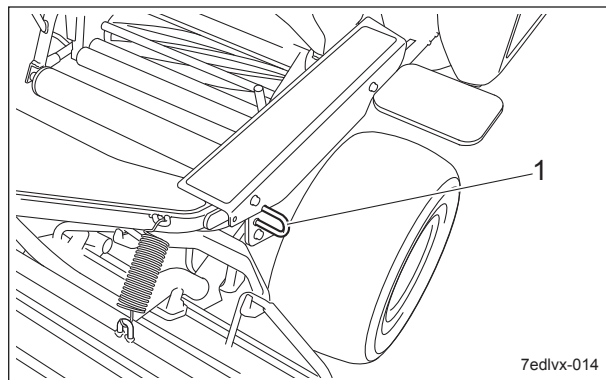

Reverse_004

1	Front hook
---	------------

4. Make sure that the parking brake is applied.
5. Start the engine, and rev it up to the maximum rpm.
6. Depress the backward pedal, and it is normal if the pressure becomes 20.6 MPa (2,987.7 psi) with the tires locked without slipping.

Hydraulic system

Up/Down circuit

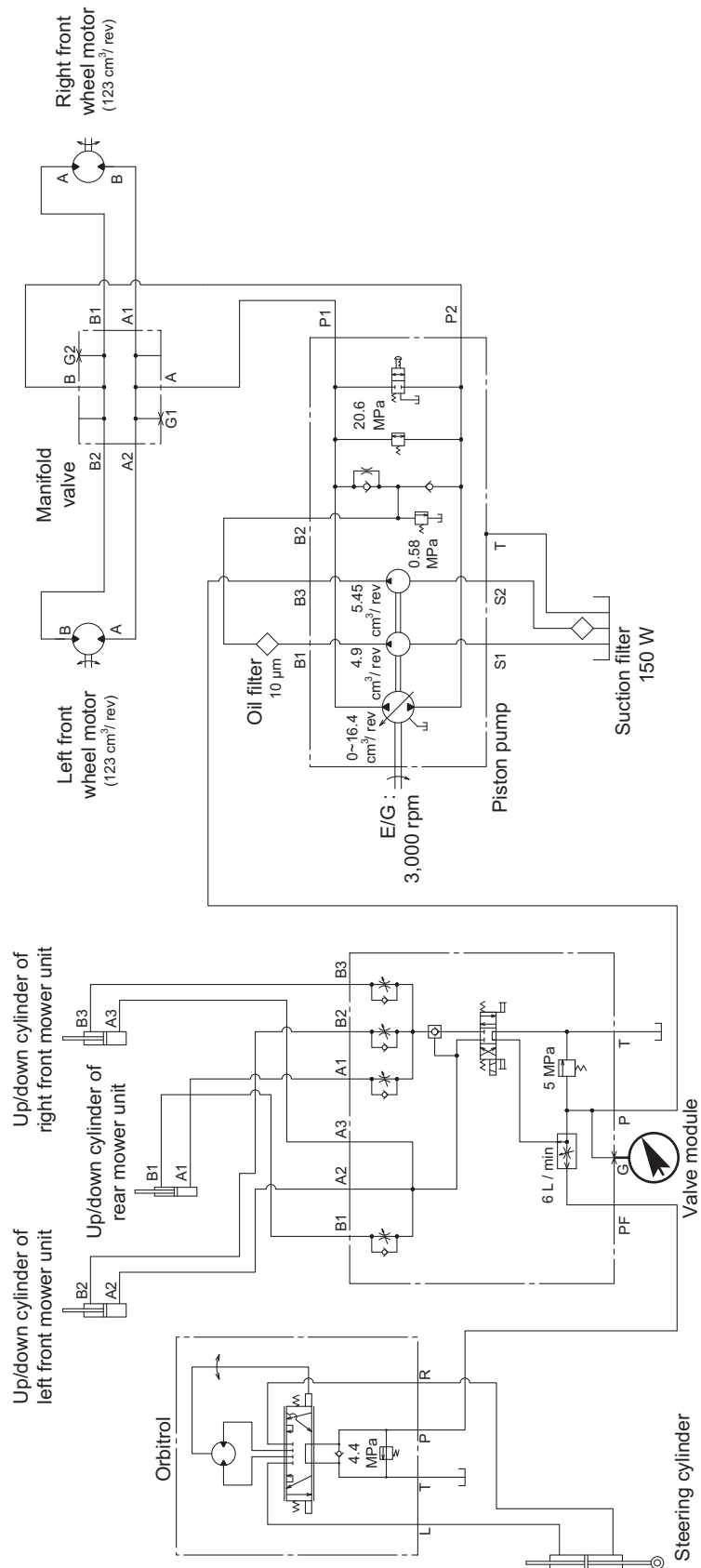

Up/Down circuit_001

z4kw7w-024

Caution

Before starting pressure measurement, make sure that there is no people around the machine.

1. Lower the mower units.
2. Remove the cap of the hydraulic measurement port G of the valve module with the hex key.

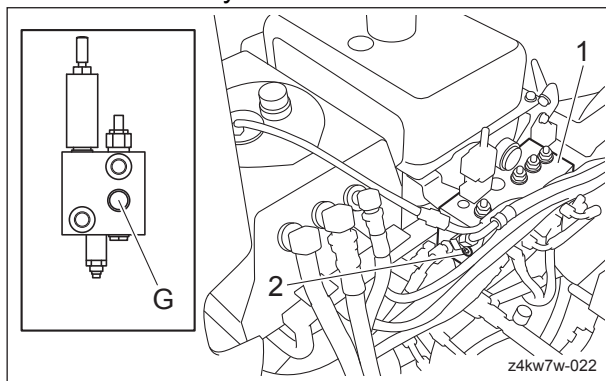

Up/Down circuit_002

1	Valve module
2	Cap

3. Install the adapter and pressure gauge for low pressure measurements at the hydraulic measurement port G.

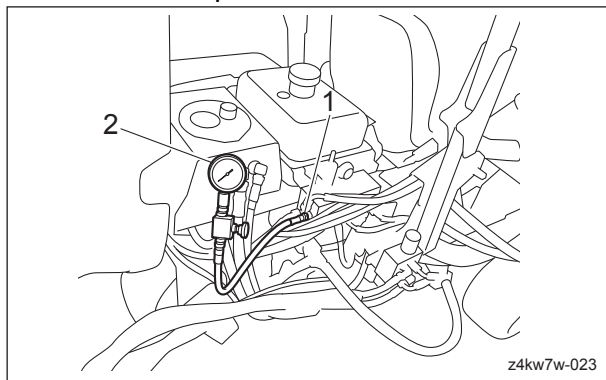

Up/Down circuit_003

1	Adapter
2	Pressure gauge for low pressure measurements

4. Make sure that the parking brake is applied.
5. Start the engine, and then raise the mower units.
6. Rev the engine up to the maximum rpm.
7. The normal pressure is 5.0 MPa (725.2 psi) when the up button is pressed and the hydraulic cylinder is shorten to the maximum extent.

⚠ Caution

Before starting pressure measurement, make sure that there is no people around the machine.

1. Remove the hydraulic hose from the elbow attached to the rear part of the steering cylinder.

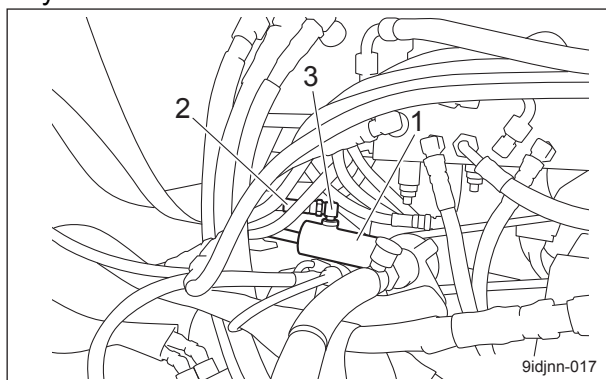

Steering Circuit_002

1	Steering cylinder
2	Hydraulic hose
3	Elbow

2. Install the pressure gauge for low pressure measurements between the removed hydraulic hose and the elbow.

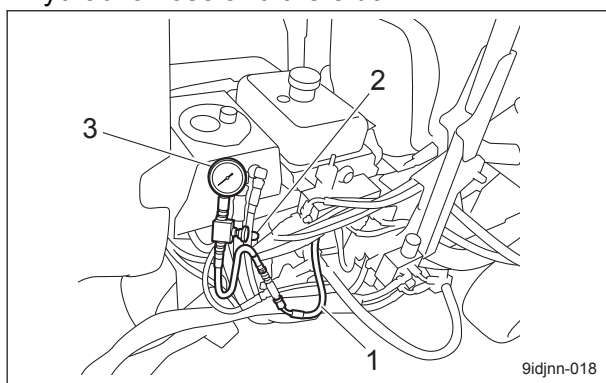

Steering Circuit_003

1	Hydraulic hose
2	Elbow
3	Pressure gauge for low pressure measurements

3. Make sure that the parking brake is applied.
4. Start the engine, and rev it up to the maximum rpm.
5. The normal pressure is 4.4 MPa (638.1 psi) when the handle is turned rightward completely.

Hydraulic system

Charge Circuit

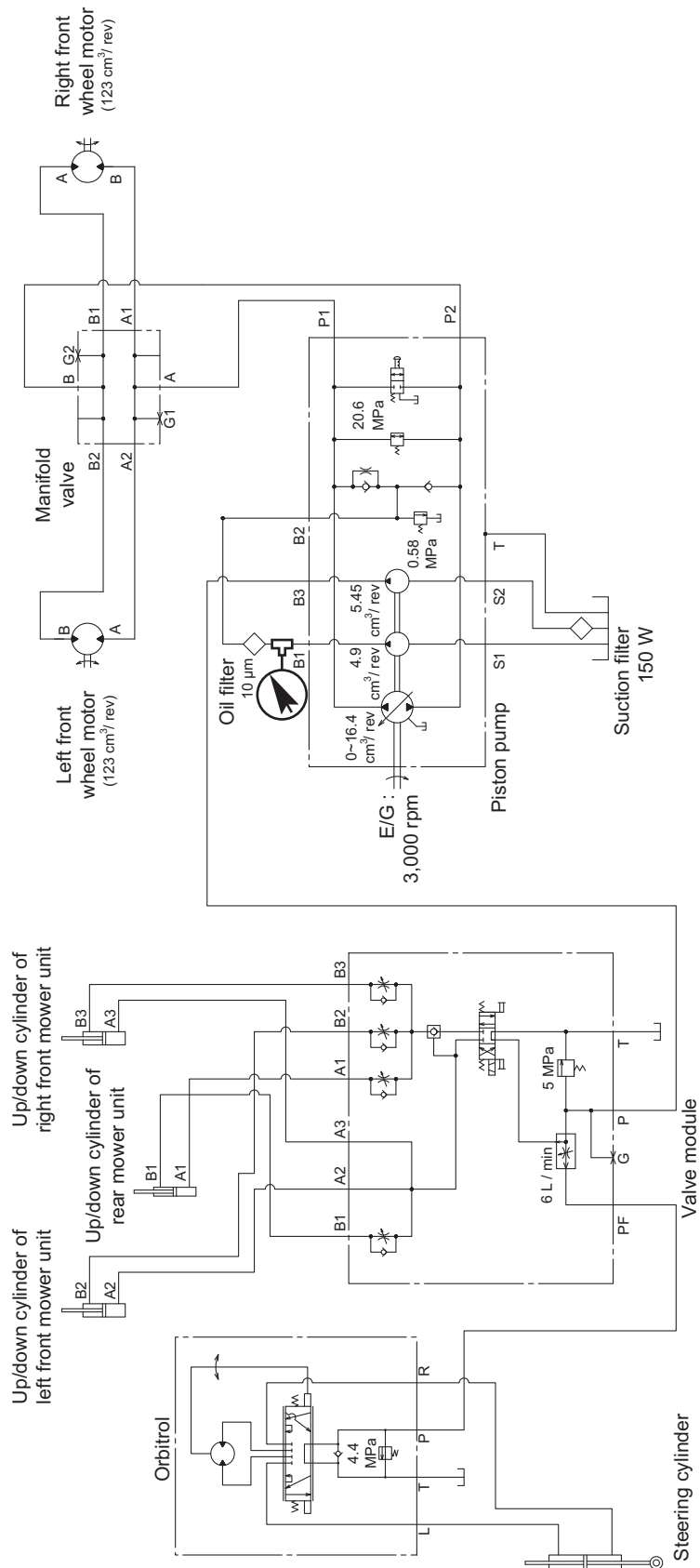

Charge Circuit_001

zg85f8-019

Caution

Before starting pressure measurement, make sure that there is no people around the machine.

1. Remove the hydraulic hose from the elbow attached to the oil filter.

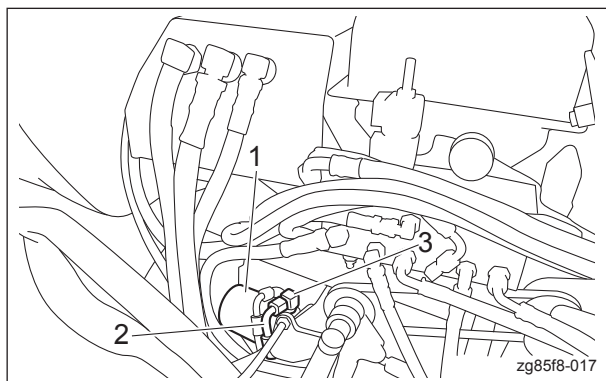

Charge Circuit_002

1	Oil filter
2	Hydraulic hose
3	Elbow

2. Install the pressure gauge for extremely low pressure measurements between the removed elbow and the hydraulic hose.

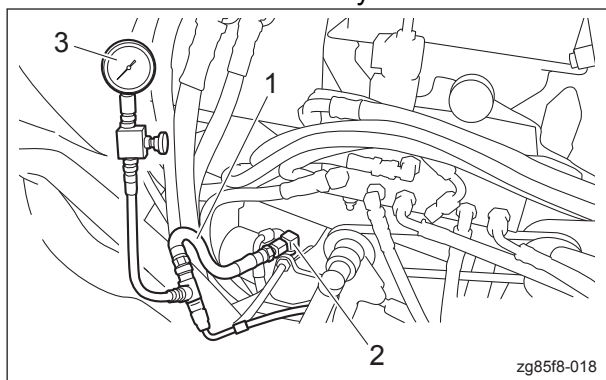

Charge Circuit_003

1	Hydraulic hose
2	Elbow
3	Pressure gauge for extremely low pressure measurements

3. Make sure that the parking brake is applied.
4. Start the engine, and rev it up to the maximum rpm.
5. The normal pressure is 0.58 MPa (84.1 psi).

Adjustment**Adjusting Mower Unit Up/Down Speed**

The Up/Down circuit of the mower unit has 4 sets of flow control valves to adjust the up/down speed.

Follow the steps below to make adjustments.

1. Warm up the hydraulic oil before the adjustment.
2. Open the hood and loosen the locknut for the flow control valve that you want to adjust.
3. To slow the speed, turn the screw to the right (direction for tightening). To quicken the speed, turn the screw to the left (direction for loosening).
4. Once the adjustment has completed, be sure to lock with the nut.

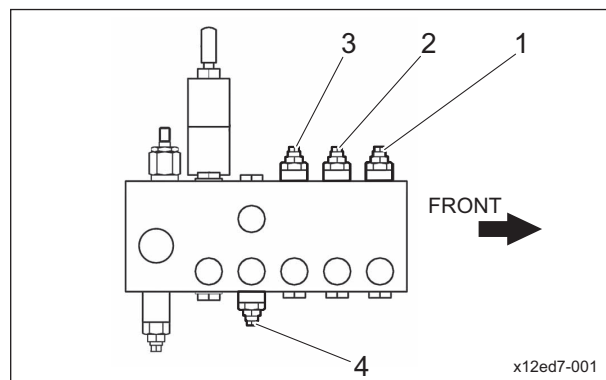

Adjusting Mower Unit Up/Down Speed_001

1	Up/down cylinder of the right front mower unit (down)
2	Up/down cylinder of the left front mower unit (down)
3	Up/down cylinder of the rear mower unit (down)
4	Up/down cylinder of the rear mower unit (up)

General inspection and repair**Note**

Before inspection and repair

1. Move the machine to level surface.
2. Apply the parking brake, and then lower the operating machine.
3. Stop the engine, and then remove the key.

Hydraulic system

- Clean the machine.
Be sure to clean parts such as the piping, hoses, and hydraulic fittings.
Remember that cleaning is always necessary upon inspection and repair of hydraulic systems.

Warning

Be sure to depressurize the hydraulic system before inspecting or repairing it.

- When piping and hoses are removed, put a cap or plug in its place to prevent contamination of the hydraulic systems.
- Attach labels or other identifications to the removed piping and hoses so that they can be correctly refitted.
- When removing piping and hoses, pay special attention to the connection part.
If necessary, mark the piping and hoses to ensure correct fitting.

After inspection and repair

Caution

After the installation, check if there is no hydraulic oil leakage in each part.
See the list in "Tightening torques" (Page 3-6).

Note that the Baroness product warranty may not apply to defects caused by incorrect or overtightening etc.

- Check the amount of oil in the hydraulic tank. Add as necessary.
In the event that failure or contamination is found in the hydraulic circuit, replace the hydraulic oil and filter.
- When fitting hydraulic fittings, apply hydraulic oil onto the O ring and seal.
- Fit hoses and hydraulic fittings only after removing the cap and plug.
- When fitting hoses and hydraulic fittings, follow the proper procedure for tightening.
- After repair, check to see whether the hydraulic system functions normally and whether there are any broken parts.
- When the hydraulic system has been repaired or replaced, operate the machine slowly, idling the engine, to allow the air to go out of the circuit.

- Make sure that there is no oil leakage.
In the event of leakage, stop the engine, set the oil stopper, and check the amount of oil in the hydraulic tank.
Add oil if necessary.

Hydraulic hose, piping

Warning

When checking for pinhole leakage of the hydraulic circuit or oil leakage of the nozzle, search for a leakage point using something like paper or cardboard, never with your bare hands. Be careful about high-pressure oil which may pierce your skin, resulting in physical injury.

Check the piping and hose every day for oil leakage, damage to the circuit, looseness, abrasion, loosening of connecting part, weather-related deterioration and chemical-related deterioration. If necessary, repair before operating the machine.

Hydraulic Oil

Important

In the event of hydraulic circuit failure, be sure to clean the circuit.

In the event of contamination or failure of the hydraulic circuit, clean and/or replace the parts. Since the hydraulic circuit is a closed circuit, any contaminant will remain within the circuit and may lead to other failures unless cleaned.

Caution

Be careful with hot oil, which could cause burns if it contacts your skin.

- Drive and maneuver the machine and warm up the hydraulic oil.
- Move the machine to level surface.
- Apply the parking brake, and then lower the operating machine.
- Stop the engine, and then remove the key.

Warning

Be sure to depressurize the hydraulic system before inspecting or repairing it.

Important

Be sure to clean the circuit connecting part to be repaired.

5. Drain the oil from the hydraulic tank.
6. Drain the oil from the hydraulic hoses and piping while the oil is still warm.
7. Replace the hydraulic oil and filter.
8. Check the hydraulic tank and clean.
9. Fit the hydraulic hoses, piping and hydraulic fittings that have been removed.

Caution

Use only the specified hydraulic oil. Use of other hydraulic oil may lead to the failure of hydraulic circuit or the like.

10. Supply new hydraulic oil.
11. Make sure that the traveling pedal and all the drives of the operating machine are in neutral position.
12. Start and run the engine for 10 seconds to check that there is no oil leakage or else. Perform this operation twice.
13. Start the engine.
Let it run idle for at least two minutes, then run at the maximum speed for one minute.
14. Raise and lower the operating machine, and turn the steering wheel side to side.
15. Stop the engine, and check for any oil leakage.
Check the amount of hydraulic oil. Add as necessary.
16. Operate for two hours under normal operating conditions.
17. Check the condition of hydraulic oil.
If it is contaminated, repeat the procedures from 1 through 15 until the oil becomes clean.
18. If no abnormality is found, operate normally and maintain according to the maintenance schedule.

Air bleeding**Caution**

When you replace or repair the motor, pump, cylinder, etc, make sure that the hydraulic system is properly connected. Make sure that air is bled to avoid malfunction.

Important

When you replace or repair hydraulic parts, be sure to replace the oil filter.

1. Move the machine to level surface.
2. Apply the parking brake, and then lower the operating machine.
3. Stop the engine, and then remove the key.
4. Make sure that the hydraulic equipments and hydraulic fittings are securely tightened.
5. When there is any malfunction of the hydraulic system or any dirt, clean the hydraulic system and the hydraulic tank, and then replace the hydraulic oil.
6. Check the amount of hydraulic oil. Add as necessary.
7. Make proper adjustment and connection, and make sure that there are neither broken parts nor oil leakage.
8. Make sure that the traveling pedal and all the drives of the operating machine are in neutral position.
9. Start and run the engine for 10 seconds to check that there is no oil leakage or else. Perform this operation twice.

Warning

Check " "Jacking up the machine" (Page 3-10) " when you jack up the machine.

10. Raise all the wheels of the machine, and then use jack stands or any proper blocks to support it firmly.
11. Make sure that the traveling pedal and all the drives of the operating machine are in neutral position.

Hydraulic system

12. Start the engine and depress the traveling pedal while it is running at low rpm. The charge pump sucks oil, air in the hydraulic system will be bled in about 30 seconds, and then the circuit will be filled with oil.
13. After the hydraulic circuit is filled with oil, operate the up/down lever and switches to operate the up/down cylinder several times. Stop the engine immediately when the cylinder does not move within 10 to 15 seconds or if there is any noise from the pump. And then check the cause. Then carry out the following inspections.
 - [1] Loose, malfunction of the filter or suction line
 - [2] Loose, malfunction of the pump coupler
 - [3] Block of the suction line
 - [4] Block of the charge relief valve
 - [5] Malfunction of the charge pump
14. Proceed to the following operation when the up/down cylinder moves within 10-15 seconds.
15. Operate the traveling pedal for forward and reverse to check if the wheels rotate in correct direction.
 - [1] When the wheels rotate in wrong direction, stop the engine and then swap the lines for the motor to correct rotation direction.
 - [2] Stop the engine when the rotation direction is correct.
16. Return the traveling pedal into the neutral position.
17. Check neutral of the traveling and make adjustment. (See the Owner's Operating Manual)
18. Lower the machine to the ground.
19. Carry out the following operations when the traveling pump or the wheel motor has been removed.
 - [1] Run for 10 minutes so as to rotate the wheels slowly.
 - [2] Then, gradually increase operation load while running for 10 minutes.
 - [3] Stop the machine, check the amount of hydraulic oil and add it as necessary. Make sure that there is no oil leakage. Check all of the connections.
- [4] Check that the traveling is in neutral position. When any adjustment is needed, raise all wheels of the machine, and then use jack stands or any proper blocks to support it firmly.

Maintenance.....	Page 5-2	Fuse box.....	Page 5-28
About Maintenance.....	Page 5-2	Buzzers.....	Page 5-29
Specifications.....	Page 5-2	Level Switch.....	Page 5-30
Adjusted Value.....	Page 5-2	General inspection and repair.....	Page 5-30
Electrical Part Layout.....	Page 5-3	Battery.....	Page 5-30
Special Tool.....	Page 5-7		
Special tools list.....	Page 5-7		
Measurement.....	Page 5-7		
Battery.....	Page 5-7		
Interlock system.....	Page 5-8		
Adjustment.....	Page 5-10		
Proximity Sensor.....	Page 5-10		
Proximity Switch.....	Page 5-12		
Limit Switch.....	Page 5-12		
Parking Brake Switch.....	Page 5-13		
Electromagnetic Clutch.....	Page 5-14		
Electrical components.....	Page 5-15		
About the Electrical components.....	Page 5-15		
Seat Switch.....	Page 5-17		
Parking Brake Switch.....	Page 5-17		
Toggle Switch.....	Page 5-17		
Up Switch.....	Page 5-18		
Proximity Switch.....	Page 5-18		
Limit Switch.....	Page 5-18		
Proximity Sensor.....	Page 5-19		
Solenoid Valve.....	Page 5-21		
Mower Unit Control Relay Unit.....	Page 5-21		
Interlock Relay Unit.....	Page 5-22		
Electromagnetic Clutch.....	Page 5-23		
Work Lamp.....	Page 5-24		
Key switch.....	Page 5-25		
Pilot lamps.....	Page 5-26		
Water temperature gauge.....	Page 5-27		
Hour meter.....	Page 5-27		
Starter Relay.....	Page 5-27		
Glow Lamp Timer.....	Page 5-28		
Fusible Link.....	Page 5-28		

Electrical system

Maintenance

About Maintenance

This chapter provides descriptions of the main inspection and maintenance procedures for the LM315GC electrical system.

For daily inspections and maintenance as well as machine handling, refer to the LM315GC Operator's Manual and Parts Catalog.

Also, for details for handling of the battery, please refer to the separate Battery Instruction Manual.

Specifications

Adjusted Value

Parking brake switch	Slight clearance	A clearance between the switch contact point and the parking brake lever when the parking brake lever is at the 4th notch
Proximity sensor (Reel rotation start position detection)	0 mm (0 in)	Horizontal distance between the sensor tip and the joint end of the tip of the right front up/down cylinder when the mower unit is lowered
	1.0 - 2.5 mm (0.04 - 0.10 in)	Clearance between the sensor detection part and the joint of the tip of the right front up/down cylinder when the mower unit is lowered
Proximity sensor (Mower unit up position detection)	415.0 mm (16.34 in)	Distance between the tip of the rear mower arm and the floor when the mower unit is raised
	1.0 - 2.5 mm (0.04 - 0.10 in)	Clearance between the sensor detection part and the cam when the mower unit is raised
	192.0 mm (7.56 in)	Length of the mower up/down cam adjustment rod
Proximity sensor (Mower unit down position detection)	285.0 mm (11.22 in)	Distance between the tip of the rear mower arm and the floor when the mower unit is lowered
	1.0 - 2.5 mm (0.04 - 0.10 in)	Clearance between the sensor detection part and the cam when the mower unit is lowered
	192.0 mm (7.56 in)	Length of the mower up/down cam adjustment rod
Proximity switch	5.0 mm (0.20 in)	Clearance between the switch and the plastic magnet when the traveling pedal is neutral
Electromagnetic clutch	0.3 - 0.6 mm (0.01 - 0.02 in)	Clearance between the clutch rotor main body and the armature board when the electromagnetic clutch is not energized
Limit switch (mower pedal switch)	75.0 mm (2.95 in)	Distance between the pedal back joint and the step when the mower pedal is released

Adjustment of Safety Switch

See "Adjustment" (Page 4-37) for method for adjustment.

Electrical Part Layout

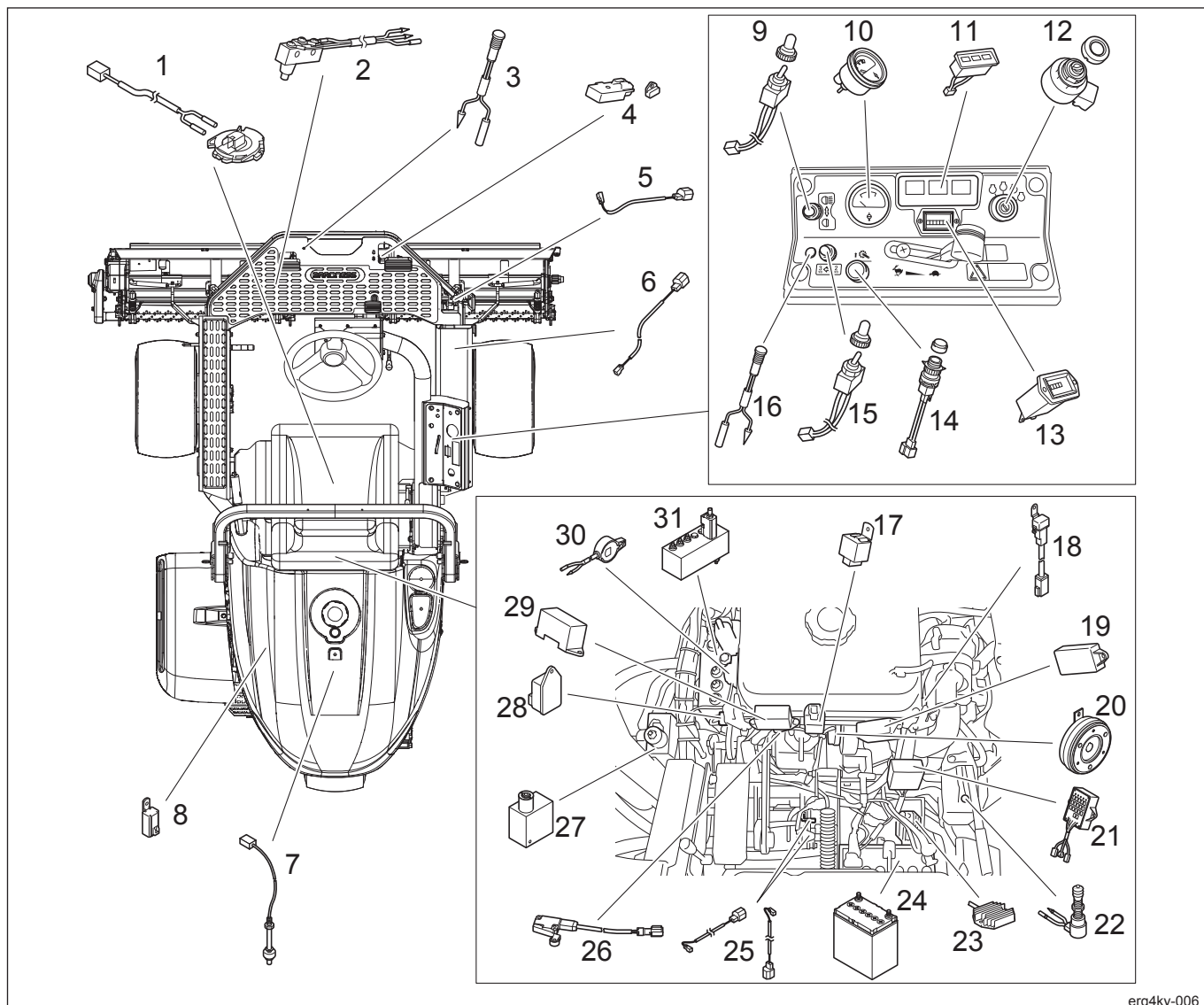

erq4ky-006

Electrical Part Layout_001

1	Seat switch	12	Key switch	23	Regulator
2	Limit switch (mower pedal switch)	13	Hour meter	24	Battery
3	LED lamp (green)	14	Up switch	25	Proximity sensor (mower unit up/down position detection)
4	Proximity switch	15	Toggle switch (2WD/3WD changeover switch)	26	Limit switch (back lapping switch)
5	Proximity sensor (reel rotation switch)	16	LED lamp (red)	27	2WD/3WD changeover valve
6	Proximity sensor (reel rotation start position detection)	17	Key stop timer	28	Glow lamp timer
7	Level Switch	18	Fusible link	29	Fuse box
8	Starter relay	19	Mower unit control relay unit	30	Buzzers
9	Toggle switch (light switch)	20	Electromagnetic clutch	31	Mower unit up/down valve
10	Water temperature gauge	21	Interlock relay unit		
11	Pilot lamps	22	Parking Brake Switch		

Electrical system

1. Seat switch
This is one of the safety switches that constitute the interlock system. It is located in the center of the seat cushion.
2. Limit switch (mower pedal switch)
The mower pedal switch is used to raise and lower the mower pedal and located in the mower pedal fulcrum.
3. LED lamp (green)
When it switches to Down position, this LED turns on. And it is located in the right side of the mower pedal.
4. Proximity switch
This is one of the safety switches that constitute the interlock system. It detects that the traveling pedal is in the neutral position.
The plastic magnet for detection is installed in the traveling pedal arm part.
It is located near the traveling pedal of the step of the operator' s foot.
5. Proximity sensor (reel rotation switch)
This is one of the safety switches that constitute the interlock system. It is used for the "rotation" and "stop" of the reel cutter.
It is located in the right side of the step of the operator' s foot.
6. Proximity sensor (reel rotation start position detection)
This is one of the safety switches that constitute the interlock system. It detects that the right front mower unit is in the down position.
It stops the rotation of the reel cutter when the mower unit is raised.
It is located in the right front mower up/down cylinder.
7. Level Switch
The level switch is connected to the buzzer (oil level).
The switch will be engaged and continuous buzzer alarm will sound if the oil volume in the hydraulic tank decreases (the float descends) by 1.2 liters (0.32 U.S.gals).
8. Starter relay
Only if the engine activation conditions of the interlock system are satisfied, the starter motor can be activated.
This is located in the left side of the hydraulic tank.
9. Toggle switch (light switch)
This is used to turn on/off the light and located on the control panel.
10. Water temperature gauge
The water temperature gauge is connected to the water temperature sensor of the engine. It indicates the temperature of engine coolant.
It is located on the control panel.
11. Pilot lamps
Status of charge of the engine, glow, and oil pressure is displayed with illumination of the lamps.
It is located on the control panel.
12. Key switch
This switch enables you to start, thermo-start, run, or stop the engine.
It is located on the control panel.
13. Hour meter
The hour meter indicates total operation time of the engine.
It is located on the control panel.
14. Up switch
This is used if the height of the mower unit is not sufficient. It is located on the control panel.
15. Toggle switch (2WD/3WD changeover switch)
This is used to switch between 2WD and 3WD and located on the control panel.

16. LED lamp (red)
This is turned on when 3WD is selected and located on the control panel.
17. Key stop timer
This controls the engine stop solenoid when the key switch is set to the "OFF" position.
It is located in front of the fuel tank.
18. Fusible link
The fusible link functions as the main fuse for the entire electrical circuit, and as the fuse for the charge circuit.
It is equipped with a specialized fuse (50A) cartridge.
It is located in the left front area of the fuel tank.
19. Mower unit control relay unit
This controls the Up/Down of the mower unit and Rotate/Stop of the reel cutter. The control can be confirmed with the light of LED.
It is located in the left front area of the fuel tank.
20. Electromagnetic clutch
This transmits/blocks the drive of the engine to the transmission.
It is located in the left side of the transmission.
21. Interlock relay unit
This is associated with various safety switch. The control can be confirmed with the light of LED.
It is located above the frame of the rear part of the battery.
22. Parking Brake Switch
The seat switch is one of the safety switches that constitute the interlock system. It is located in the fulcrum of the parking brake lever.
23. Regulator
This controls the amount of charge from the alternator. It is located above the frame of the rear part of the battery.
24. Battery
The battery supplies power to the starter motor at the start of the engine, as well as to all electrical parts.
This is located under the seat.
25. Proximity sensor (mower unit up/down position detection)
This detects the rear mower arm stop position when the mower unit is raised.
It is located under the seat and two units are installed to detect the up and down positions.
26. Limit switch (back lapping switch)
This is one of the safety switches that constitute the interlock system. It detects that the transmission selector lever is in the "LAP" position.
It is located near the transmission selector lever.
27. 2WD/3WD changeover valve
You can activate the 2WD/3WD changeover valve to enable "2WD" or "3WD" driving by operating the 2WD/3WD changeover switch.
It is located in the center of the right side of the body.
28. Glow lamp timer
This controls illumination of the thermo-start lamp inside the pilot lamp.
When the ignition key switch is set and held to "GLOW" position, the thermo-start lamp turns on for 5 seconds.
It is located on the control panel.
29. Fuse box
Each electrical device is connected through the fuse from the key switch.
Fuse standards are the same as those of "mini fuses for automobiles."
It is located in front of the fuel tank.

Electrical system

30. Buzzers

The buzzers sound when overheating, abnormal hydraulic oil level, or traveling while the parking brake is applied is detected. (intermittent tone)

31. Mower unit up/down valve

This is activated by the operation of the limit switch (mower pedal switch) and switches the hydraulic circuit inside the valve module.

It is composed of two solenoids for up and down motions.

It is located in the valve module.

Special Tool

Special tools list

No use of special tools is required.

Measurement

Battery

Measurement of Battery Specific Weight

Specific weight of electrolyte tends to reduce in linear proportion with the discharged electrical quantity of the battery and so checking the specific weight of electrolyte with a hydrometer can tell the remaining capacity of the battery. Temperature compensation is required for the specific weight measured with a hydrometer. The standard temperature for the specific weight of battery electrolyte is 20 ° C, and the specific weight increases or decreases by 0.0007 in accordance with the temperature change of 1 ° C. Thus it can be compensated by the following formula.

$$S_{20} = S_t + 0.0007(t - 20)$$

Measurement of Battery Specific Weight_001

1	Specific weight converted for 20 ° C
2	Measured specific weight
3	Fluid temperature at measurement

Specific weight and remaining capacity of battery		
Specific weight (20 ° C)	Discharged electrical quantity (%)	Remaining capacity (%)
1.28	0	100
1.24	25	75
1.20	50	50
1.16	75	25
1.12	100	0

Measurement of specific weight of 12V battery

1. Check all the cells after charge.

2. Replace it when the specific weight is 1.225 or less, or gap of that between each cell is 0.05 or more.

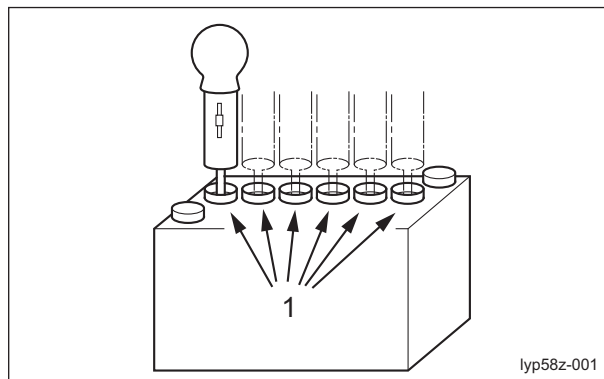

Measurement of Battery Specific Weight_002

1	Cell
---	------

Battery charging

Follow this procedure to fully charge the battery.

Warning

When charging the battery, do not use a current in excess of one tenth of the rated current. With regard to the maximum recommended charging current, follow the battery manufacturer's instructions.

Caution

If the battery gets extremely hot or releases a significant amount of gas during charging, unplug the battery charger at regular intervals.

1. Use a taper battery charger, which automatically reduces the charging rate during charging.
2. After charging is completed, fill the battery cells with distilled water (if the battery is in use).
3. After charging is completed, measure and record the specific gravity of each cell using a battery hydrometer. (See "Measurement of Battery Specific Weight" (Page 5-7) .)
4. Replace it when the specific weight is 1.225 or less, or gap of that between each cell is 0.05 or more.

Electrical system

Interlock system

The interlock system is a safety system to prevent injury or accident caused by lack of caution of operator using combined control with multiple switches and sensors.

The engine stop solenoid operates simultaneously with the seat switch, parking brake switch, proximity switch, proximity sensor (reel rotation switch) and back lapping switch. In addition the electromagnetic clutch operates simultaneously with the seat switch, proximity sensor (reel rotation switch) and limit switch (back lapping switch).

To start the engine,

- [1] An operator sits on the seat.
- [2] The parking brake is applied.
- [3] Set the position of the proximity switch (reel rotation switch) to "OFF."
- [4] Take the foot off the traveling pedal (forward or reverse pedal).

To drive,

- [1] An operator sits on the seat.
- [2] Release the parking brake.
- [3] Hit the traveling pedal (forward or reverse pedal).

In the following case, the engine is stopped.

- Apply the parking brake, leave the driver's seat, and hit the traveling pedal (forward or reverse pedal).
- Release the parking brake without sitting on the driver's seat.
- Apply the parking brake, and turn the proximity switch (reel rotation switch) "ON" without sitting on the driver's seat.

To operate (reel rotation),

- [1] An operator sits on the seat.
- [2] Turn the proximity sensor (reel rotation switch) "ON."
 - If the operator leaves the driver's seat, the engine is stopped.
- [3] Lower the mower units.

When the machine is parked or stopped,

- [1] Apply the parking brake.
- [2] In the event the operator leaves the seat, set the proximity sensor (reel rotation switch) to the "OFF" position.

- [3] Take the foot off the traveling pedal (forward or reverse pedal).
 - Unless the operator leaves the driver's seat, the engine is not stopped.
 - However, unless all of the above-mentioned conditions are satisfied, the interlock system is activated and the engine is stopped.

Maintenance of back lapping (The reel cutter rotates reversely)

- [1] Lower the mower units.
- [2] Stop the engine.
- [3] Set the reel reverse lever to "Reverse" position, then set the transmission selector lever to "LAP" position.
 - For the mower units not to back lap, set the reel reverse lever to the "N" position.
- [4] An operator sits on the seat.
- [5] Apply the parking brake.
- [6] Take the foot off the traveling pedal (forward or reverse pedal).
- [7] Start the engine, and run it at a low rpm.
- [8] Set the proximity sensor (reel rotation switch) to the "ON" position.

Interlock System Operation Requirements

	Seat	Parking brake	Transmission selector lever	Reel rotation switch	Traveling pedal
To start the engine,	ON (Sitting)	ON (Applied)	-	OFF	OFF (Take the foot off)
To drive,	ON (Sitting)	OFF (Released)	-	-	ON (Forward or reverse)
To operate (reel rotation),	ON (Sitting)	OFF (Released)	-	ON	-
When the machine is parked or stopped,	-	ON (Applied)	-	OFF	OFF (Take the foot off)
Maintenance of back lapping (The reel cutter rotates reversely)	-	ON (Applied)	ON (LAP)	ON	OFF (Take the foot off)

Confirming Operation of Interlock System

1. For the status of the engine start, check if the engine will stop when even one of the operation conditions on the seat, the parking brake, the reel rotation switch and traveling pedal is not met.
2. For the status of the back lapping maintenance, check if the electromagnetic clutch will be separated or the engine will stop when even one of the operation conditions on the parking brake, the reel rotation switch, traveling pedal and transmission selector lever is not met.

Electrical system

Adjustment

Proximity Sensor

Reel Rotation Circuit

■ Adjustment of Reel Rotation Start Position

The rotations/stops of the reel associated with the up/down motions of the mower unit are adjusted by the joint of the tip of the right front mower unit up/down cylinder and proximity sensor (reel rotation start position detection).

1. Start the engine.
2. Lower the mower units.
3. Stop the engine.
4. Remove the cover in the upper part of the right front mower up/down cylinder.

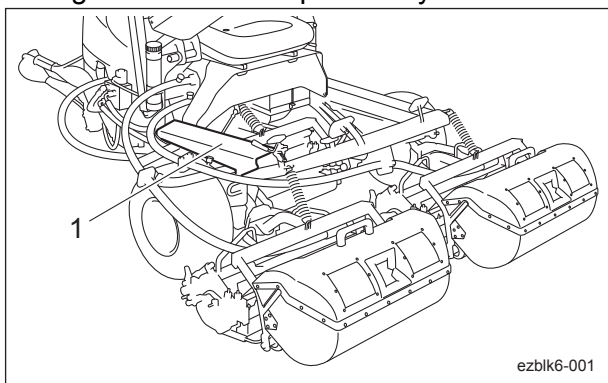

Adjustment of Reel Rotation Start Position_001

1	Cover
---	-------

5. Adjust the position of the proximity sensor (reel rotation start position detection) by the following steps.
 - [1] Loosen bolt A so that the sensor mounting plate can be moved.
 - [2] Move the sensor mounting plate in the front/back direction and then tighten bolt A in the position where the joint end of the up/down cylinder tip fits the sensor detection part end.
 - [3] Loosen bolt B so that the sensor mounting plate can be moved.

- [4] Tighten bolt B in the position where the clearance between the up/down cylinder tip and proximity sensor is 1.0 - 2.5 mm (0.04 - 0.10 in).

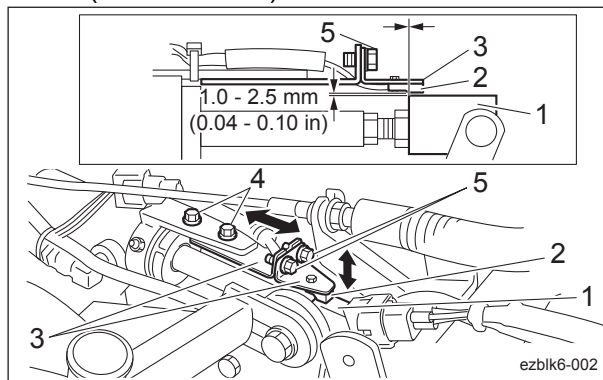

Adjustment of Reel Rotation Start Position_002

1	Up/Down cylinder tip joint
2	Proximity sensor (reel rotation start position detection)
3	Sensor mounting plate
4	Bolt A
5	Bolt B

6. Install the cover in the upper part of the right front mower up/down cylinder.

Mower Unit Up/Down Circuit

■ Adjustment of Up/Down Position

The mower arm stop position when the mower unit is raised/lowered is adjusted by the cam under the seat and two proximity sensors (mower up/down position detection).

1. Loosen the nut and rotate the rod to adjust the mower up/down cam adjustment rod to 192.0 mm (7.56 in).
2. Tighten the nut.

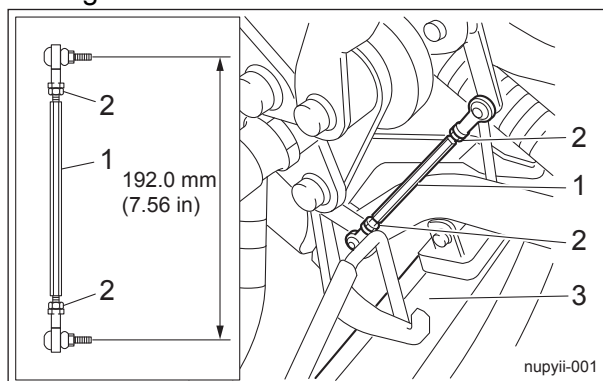

Adjustment of Up/Down Position_001

1	Mower up/down cam adjustment rod
2	Nut
3	Rear mower unit

Electrical system

3. Start the engine.
4. Lower the mower units.
5. Stop the engine.
6. Remove the mower mounting bracket and the flexible wire of the rear mower unit and then the rear mower unit.

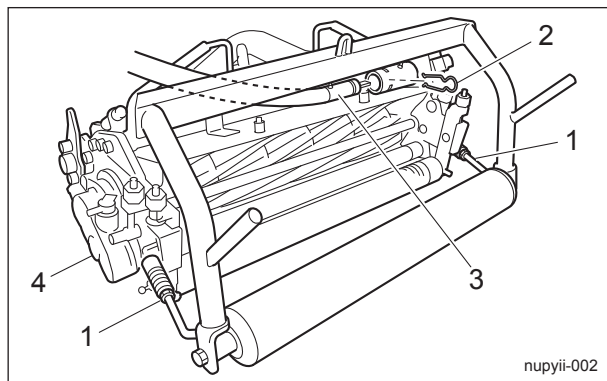

Adjustment of Up/Down Position_002

1	Mower mounting bracket
2	Clip
3	Flexible wire
4	Rear mower unit

7. Adjust the position of the proximity sensor (mower down position detection) by the following steps.

- [1] Loosen the bolt so that the sensor mounting plate can be moved.
- [2] Move the sensor mounting plate in the front/back direction and then tighten the bolt in the position where the distance from the rear mower arm tip to the ground is 285.0 mm (11.22 in).

Important

Adjust the proximity sensor to detect the front end of the cam.

- [3] Make sure that the clearance of the cam and proximity sensor is 1.0 to 2.5 mm (0.04 to 0.10 in).

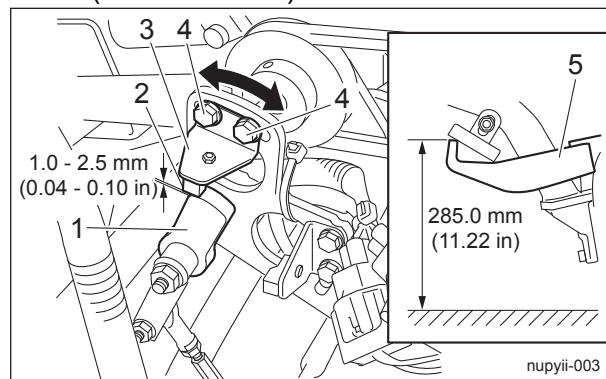

Adjustment of Up/Down Position_003

1	Cam
2	Proximity sensor (mower down position detection)
3	Sensor mounting plate
4	Bolt
5	Rear mower arm

8. Start the engine.
9. Raise the mower units.
10. Adjust the position of the proximity sensor (mower up position detection) by the following steps.
 - [1] Loosen the bolt so that the sensor mounting plate can be moved.
 - [2] Move the sensor mounting plate in the up/down direction and then tighten the bolt in the position where the distance from the rear mower arm tip to the ground is 415.0 mm (16.34 in).

Electrical system

Important

Adjust the proximity sensor to detect the rear end of the cam.

[3] Make sure that the clearance of the cam and proximity sensor is 1.0 to 2.5 mm (0.04 to 0.10 in).

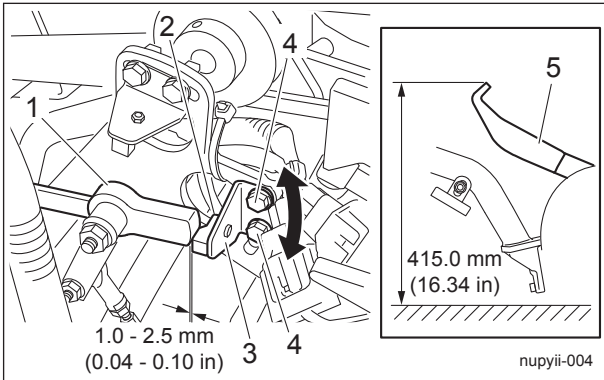

Adjustment of Up/Down Position_004

1	Cam
2	Proximity sensor (mower up position detection)
3	Sensor mounting plate
4	Bolt
5	Rear mower arm

11. Start the engine.
12. Lower the mower units.
13. Install the rear mower unit.

Proximity Switch

Neutral Position of Traveling Pedal

Adjust the position of the proximity switch so that the clearance between the proximity switch and plastic magnet becomes within 5.0 mm (0.20 in) when the traveling pedal is in the neutral position.

1. Adjust it by loosening the bolt and by moving the sensor mounting board parallel to the plastic magnet.

2. Tighten the bolt being careful not to move the sensor mounting board.

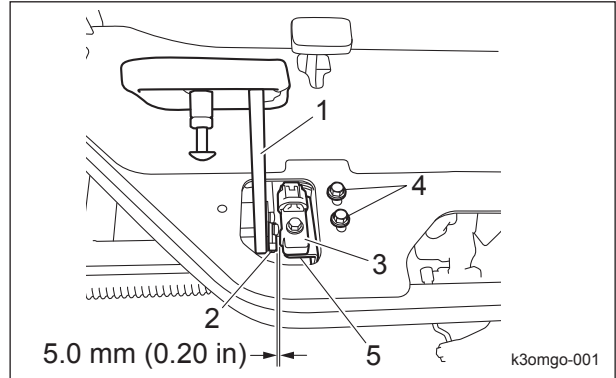

Neutral Position of Traveling Pedal_001

1	Traveling pedal
2	Plastic magnet for detection
3	Proximity switch
4	Bolt
5	Sensor mounting board

Limit Switch

Adjustment of Mower Pedal Switch

1. Loosen the nut and rotate the spring adjustment screw to the extent that there is no play in the spring.
2. Tighten the nut being careful not to rotate the spring adjustment screw.
3. Set the key switch to the "ON" position.
4. Loosen the nut and rotate the mower pedal stopper bolt to adjust the mower pedal, so that it stops in the position where it is tighten one revolution from the position where the switch is turned "ON" (LED (green) is turned on).
5. Tighten the nut being careful not to rotate the mower pedal stopper bolt.
6. Set the key switch to the "OFF" position.

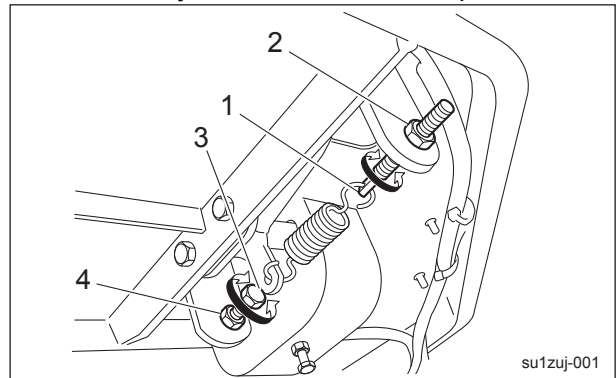

Adjustment of Mower Pedal Switch_001

1	Spring adjustment screw
2	Nut (for spring adjustment screw)
3	Mower pedal stopper bolt
4	Nut (for mower pedal stopper bolt)

- Adjust the distance between the pedal back joint and the step to 75.0 mm (2.95 in) by loosening the nut and rotating the mower pedal height adjustment bolt.
- Tighten the nut being careful not to rotate the mower pedal height adjustment bolt.

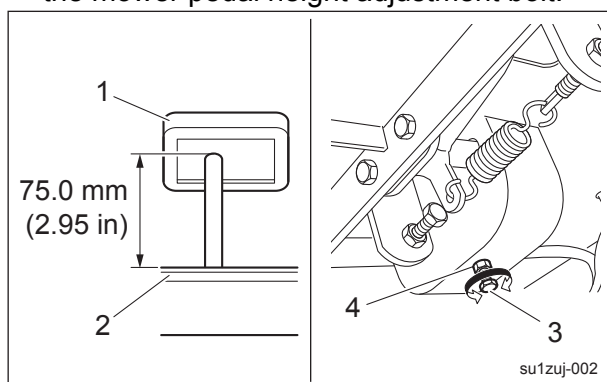

Adjustment of Mower Pedal Switch_002

1	Mower pedal
2	Step
3	Mower pedal height adjustment bolt
4	Nut (for mower pedal height adjustment bolt)

Adjustment of Back Lapping Switch

- Loosen the back lapping switch attaching screw.
- Set the transmission selector lever to the "LAP" position.
- Adjust the switch angle so that the back lapping switch becomes "ON."

Important

Keep the lever part of the back lapping switch not touching the main body of the switch. If the switch contact point is pressed more than a stroke of the switch, the switch may be damaged.

- Tighten the back lapping switch attaching screw.

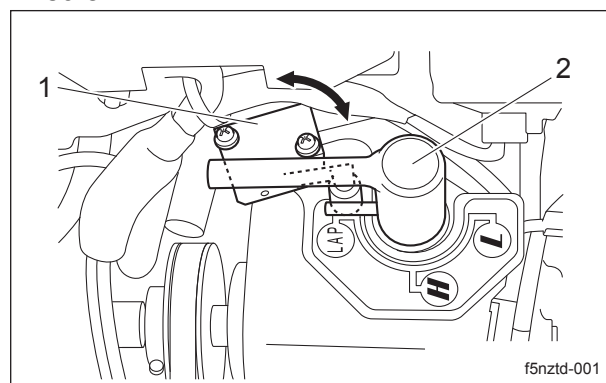

Adjustment of Back Lapping Switch_001

1	Limit switch (back lapping switch)
2	Transmission selector lever

Parking Brake Switch

The parking brake is equipped with a parking brake switch, one part of the interlock system. The switch contact point is activated through the operation of the parking brake lever, controlling starting and stopping of the engine.

- Apply the parking brake lever.

Electrical system

Important

After adjusting the parking brake wire, check that the machine is firmly stopped at notch 4 - 5.

2. With the parking brake at notch 4, adjust the adjustment nut of the parking brake switch to create a slight clearance at the switch contact point.

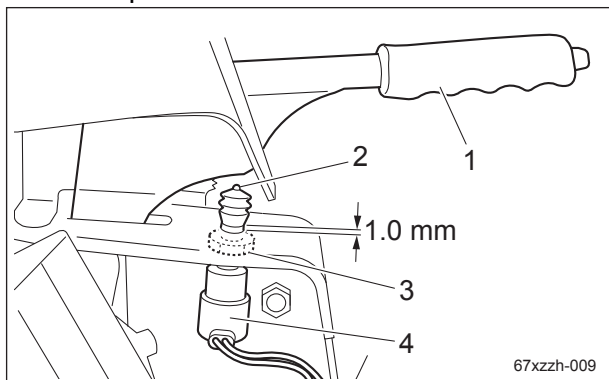

Parking Brake Switch_002

1	Parking Brake Lever
2	Switch contact point
3	Adjustment nut
4	Parking Brake Switch

Important

The screw part of the parking brake switch should not protrude by 1.0 mm (0.04 in) or more.

If the switch contact point is pressed more than a stroke of the switch, the switch may be damaged.

3. Release the parking brake, and then make sure that the switch contact point is pressed.
4. Follow the steps below to check the operation of the parking brake switch.
 - [1] While sitting on the seat with the parking brake set to at least notch 4 and the reel switch set to the OFF position, check that the engine starts.
 - [2] Check that the engine is stopped when you release the parking brake and leave the seat. (See "Interlock system" (Page 5-8))

Electromagnetic Clutch

The electromagnetic clutch is composed of the main body of the clutch rotor and armature board.

It is installed between the transmission and the transmission driver pulley, and connected with the armature board installed to the pulley when the main body of the clutch is conducted, and transmits the drive of the engine to the transmission.

1. Remove the transmission drive belt and transmission drive pulley.
2. Install the pulley with placing two 0.1 mm shims, one 0.3 mm shim and one 0.5 mm shim at the front/back of that pulley. .

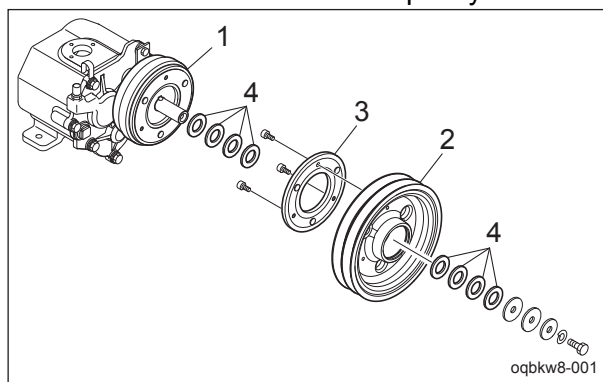

Electromagnetic Clutch_001

1	Main body of the clutch rotor
2	Pulley
3	Armature board
4	Shim

3. Measure the clearance between the main body of the clutch rotor and armature board to make sure that it is 0.3 - 0.6 mm (0.01 - 0.02 in).
If it is out of the range, remove the pulley again and then adjust it by rearranging the shims in front/back of that pulley so that the clearance is within the range.

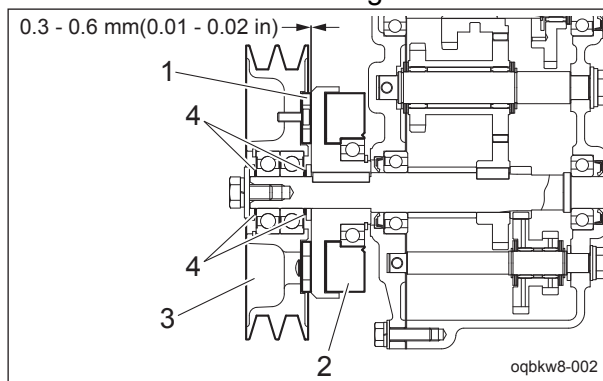

Electromagnetic Clutch_002

Electrical system

1	Armature board
2	Main body of the clutch rotor
3	Pulley
4	Shim

4. Install the transmission drive belt.
5. Make sure that the electromagnetic clutch works properly. "See "Electromagnetic Clutch" (Page 5-23) "

Electrical components

About the Electrical components



Warning
When servicing electrical components, be sure to disconnect the negative battery cable.

Safety Switches

The following devices are used as safety switches to prevent injuries and accidents due to operator inattentiveness.

Related to engine starting and operation (See "Interlock system" (Page 5-8) ".)

- Seat switch
- Parking Brake Switch
- Proximity sensor (reel rotation switch)
- Proximity switch
- Limit switch (back lapping switch)

Reel Rotation Circuit

The rotation of the reel cutter is controlled by the proximity sensor (reel rotation switch), proximity sensor (reel rotation start position detection), interlock relay unit, mower unit control relay unit, and electromagnetic clutch.

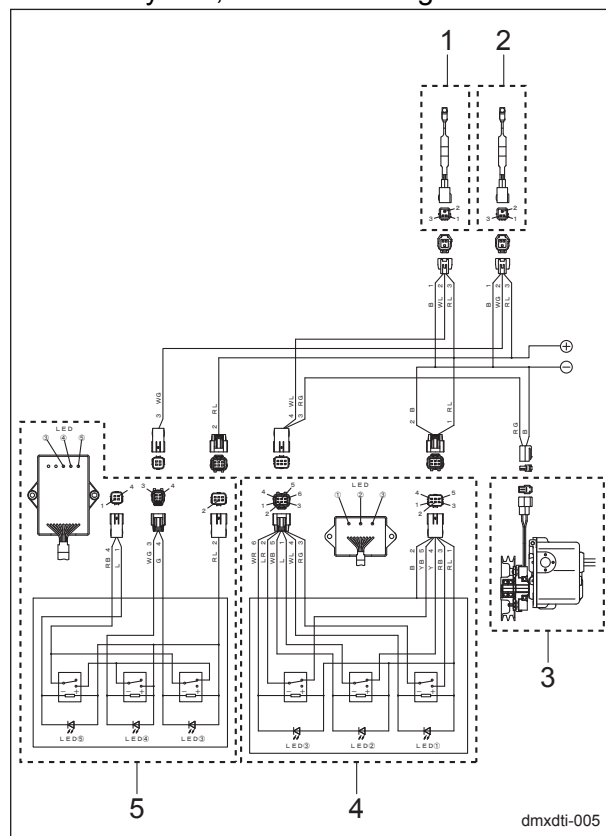

Reel Rotation Circuit_001

1	Proximity sensor (reel rotation start position detection)
2	Proximity sensor (reel rotation switch)
3	Electromagnetic clutch
4	Mower Unit Control Relay Unit
5	Interlock Relay Unit

Electrical system

Mower Unit Up/Down Circuit

The up/down motion of the mower unit is controlled by the limit switch (mower pedal switch), proximity sensor (mower unit up/down position detection), up switch, mower unit control relay unit, and valve module.

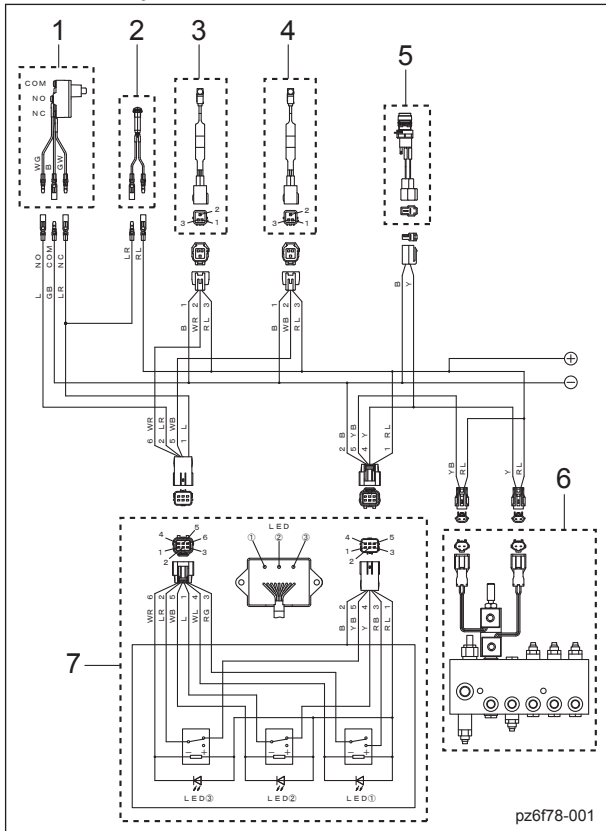

Mower Unit Up/Down Circuit_001

1	Limit switch (mower pedal switch)
2	LED lamp (green)
3	Proximity sensor (mower unit down position detection)
4	Proximity sensor (mower unit up position detection)
5	Up switch
6	Valve module
7	Mower Unit Control Relay Unit

2WD/3WD Changeover Circuit

2WD/3WD changeover is controlled by the proximity sensor (reel rotation switch), toggle switch (2WD/3WD changeover switch), 2WD/3WD changeover valve, and interlock relay unit.

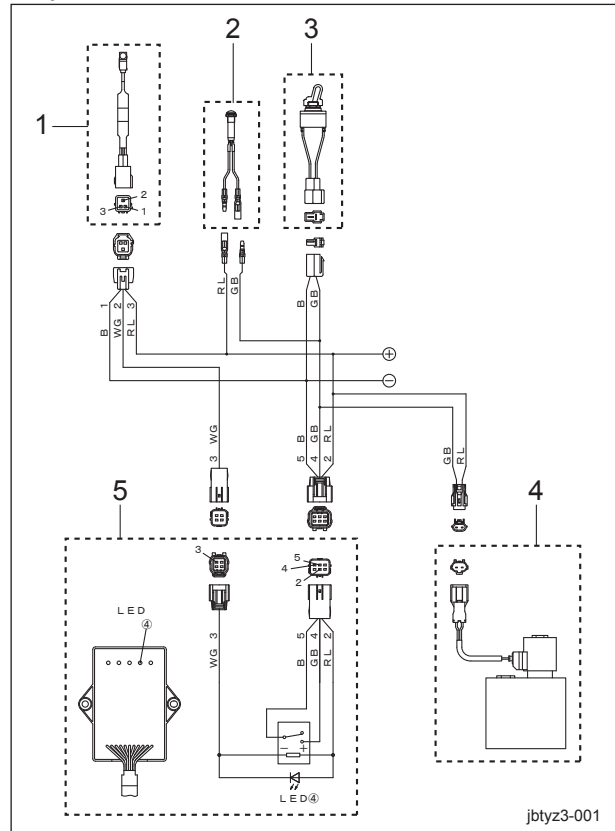

2WD/3WD Changeover Circuit_001

1	Proximity sensor (reel rotation switch)
2	LED lamp (red)
3	Toggle switch (2WD/3WD changeover switch)
4	2WD/3WD Changeover Valve
5	Interlock relay unit

Seat Switch

The seat switch is located right underneath the seat and is usually conducted. It is normal if its condition is stopped when seated.

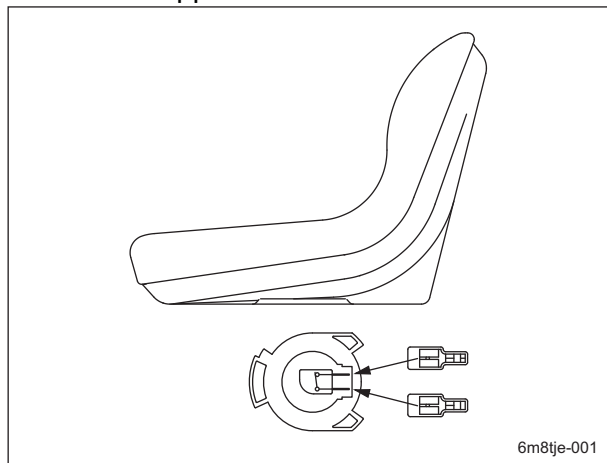

Seat Switch_001

Parking Brake Switch

The parking brake switch is located in the fulcrum of the parking brake lever.

1. It is normal if the two wires of the parking brake switch are conducted between them when the parking brake lever is pulled. (Condition that switch operation part is completely extended)
2. It is normal if the two wires of the parking brake switch are not conducted between them when the parking brake lever is released. [Condition that switch operation part is completely retracted]

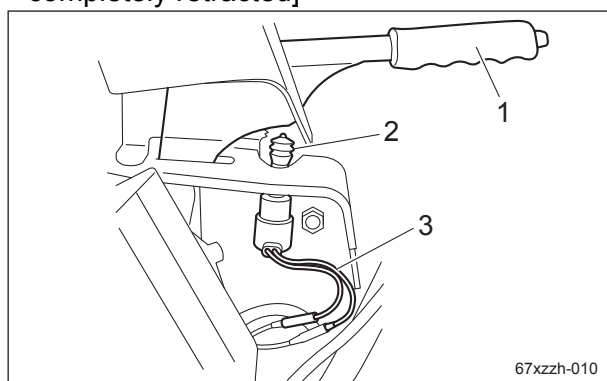

Parking Brake Switch_001

1	Parking Brake Lever
2	Parking Brake Switch
3	Wire

Toggle Switch

2WD/3WD Changeover Switch

The 2WD/3WD changeover switch is located in the operation panel.

1. Remove the operation panel cover.
2. It is normal if there is conduction between the connector terminals when the 2WD/3WD changeover switch is pressed towards the 3WD position.
3. It is normal if there is no conduction between the connector terminals when the 2WD/3WD changeover switch is pressed towards the 2WD position.

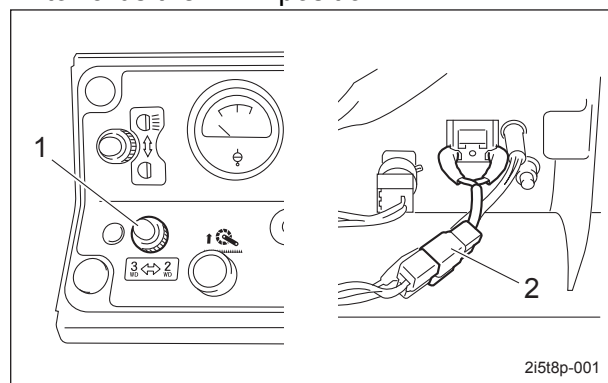

2WD/3WD Changeover Switch_001

1	Toggle switch (2WD/3WD changeover switch)
2	Connector

Light Switch

The light switch is located in the operation panel.

1. Remove the operation panel cover.
2. It is normal if there is conduction between the connector terminals when the light switch is pressed towards the ON position.

Electrical system

- It is normal if there is no conduction between the connector terminals when the light switch is pressed towards the OFF position.

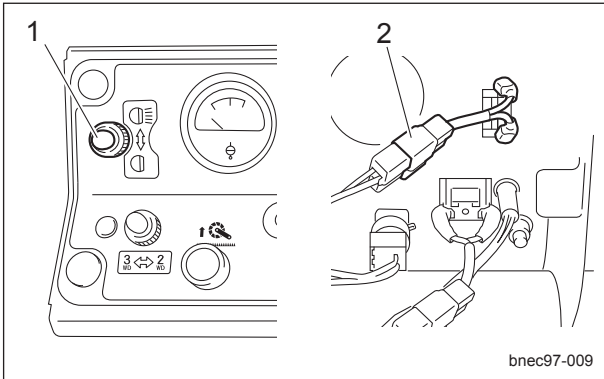

Light Switch_001

1	Toggle switch (light switch)
2	Connector

Up Switch

The up switch is located in the operation panel.

- Remove the operation panel cover.
- It is normal if there is conduction between the connector terminals when the up switch is pressed.
- It is normal if there is no conduction between the connector terminals when the up switch is released.

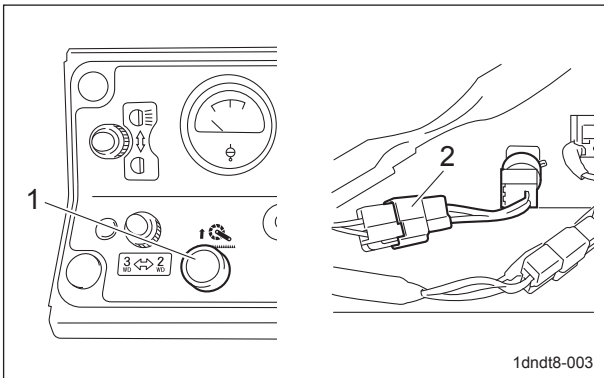

Up Switch_001

1	Up switch
2	Connector

Proximity Switch

The proximity switch is located near the traveling pedal of the frame and the plastic magnet for detection is attached to the traveling pedal arm part.

When the traveling pedal is neutral, the proximity switch detects the plastic magnet.

- Remove the 4-pin connector (male) of the interlock relay unit from the counterpart 4-pin connector.
- Set the key switch to the "ON" position and then follow the following inspection steps.

[1] Make sure that there is conduction between the counterpart 4-pin connector terminal (white red) and the body (ground) when the traveling pedal is neutral.

[2] Make sure that there is no conduction between the counterpart 4-pin connector terminal (white red) and the body (ground) when the traveling pedal is pressed.

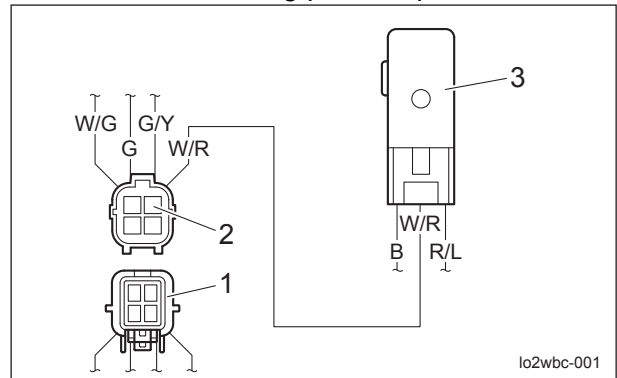

Proximity Switch_001

1	Interlock relay unit 4-pin connector (male)
2	Connector terminal (white red/ proximity sensor signal)
3	Proximity Switch

Limit Switch

Mower Pedal Switch

The mower pedal switch is located in the mower pedal fulcrum port.

- Remove the mower pedal switch cover.

2. Inspect the conduction of the mower pedal switch.

It is normal if the wire to be conducted to the wire (black) switches every time the switch is pressed.

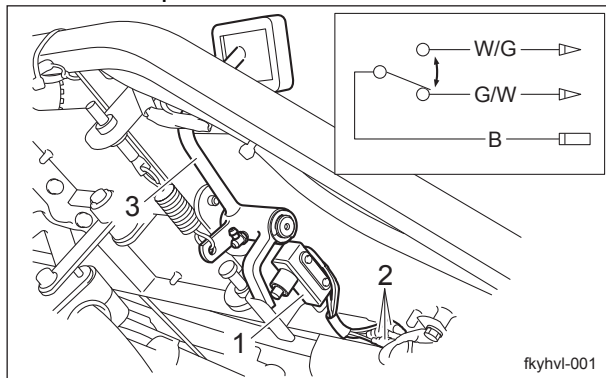

Mower Pedal Switch_001

1	Limit switch (mower pedal switch)
2	Wire
3	Mower pedal

3. Install the mower pedal switch cover.

Back Lapping Switch

The back lapping switch is located near the transmission selector lever.

1. It is normal if there is conduction between the connector terminals when the transmission selector lever is set to the "LAP" position.
2. It is normal if there is no conduction between the connector terminals when the transmission selector lever is set to the "H" or "L" position.

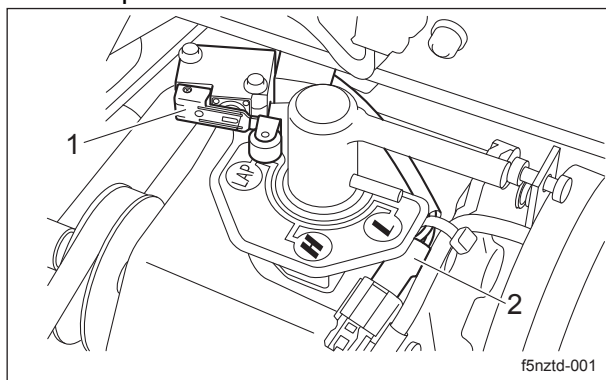

Back Lapping Switch_001

1	Limit switch (back lapping switch)
2	Connector

Proximity Sensor

Proximity sensors detect that objects are nearby through non-contact methods.

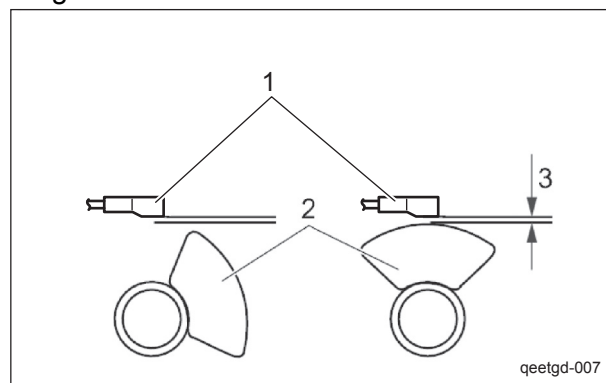

Proximity Sensor_001

1	Proximity Sensor
2	Object (metal)
3	Setting value [1.0 - 2.5 mm (0.04 - 0.10 in)]

1. If an object gets close to the proximity sensor, the sensor is set to the "ON" position and the operation indicator lights up in red.
2. If an object is away from the proximity sensor, the sensor is set to the "OFF" position and the operation indicator turns off.

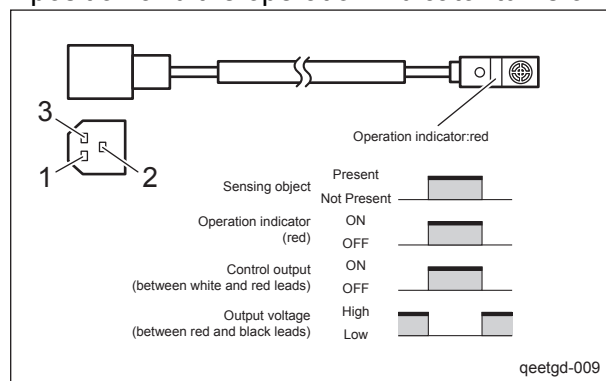

Proximity Sensor_002

1	Connector terminal (white/+)
2	Connector terminal (red/output)
3	Connector terminal (black/-)

Inspection of Action Indicator

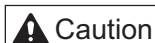

Do not short-circuit the battery terminals.

1. Connect the battery (+) to the connector terminal (white/+), and the battery (-) to the connector terminal (black/-).

Electrical system

2. It is normal if the action indicator is illuminated red when the object to be detected is close to the proximity sensor, and the action indicator is turned off when the object is away from the proximity sensor.

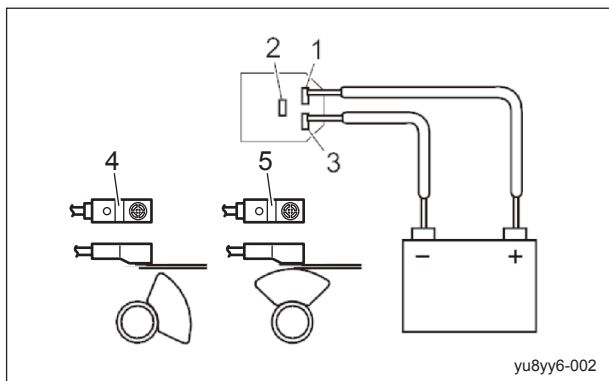

Inspection of Action Indicator_001

1	Connector terminal (white/+)
2	Connector terminal (red/output)
3	Connector terminal (black/-)
4	OFF
5	ON (red)

Inspection of Control Output

Caution

Do not short-circuit the battery terminals.

1. Connect the battery (+) to the connector terminal (white/+), and the battery (-) to the connector terminal (black/-).
2. It is normal if there is conduction between the connector terminal 2 and 3 when the object to be detected is close to the proximity sensor, and there is no conduction between the connector terminal 2 and 3 when the object is away from the proximity sensor.

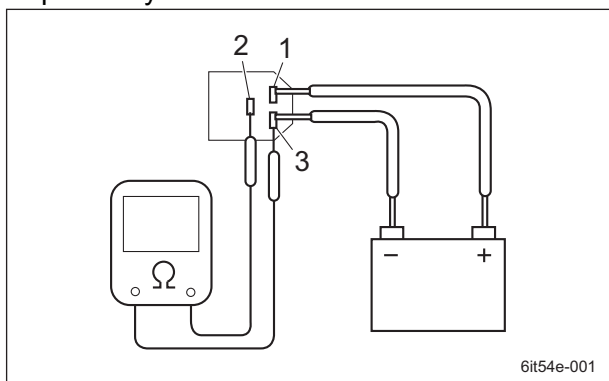

Inspection of Control Output_001

1	Connector terminal (white/+)
2	Connector terminal (red/output)
3	Connector terminal (black/-)

Inspection of Output Voltage

Caution

Do not short-circuit the battery terminals.

1. Follow the steps below to connect the battery and voltmeter.
 - [1] Connect the battery (+) to the connector terminal (white/+), and the battery (-) to the connector terminal (black/-).
 - [2] Connect the voltmeter (+) to the connector terminal (red/output) and the voltmeter (-) to the connector terminal (black/-).
2. It is normal if the voltage between the connector terminals 2 and 3 is 0 V when the object to be detected is close to the proximity sensor, and the voltage between the connector terminals 2 and 3 is battery voltage (12 V) when the object is away from the proximity sensor.

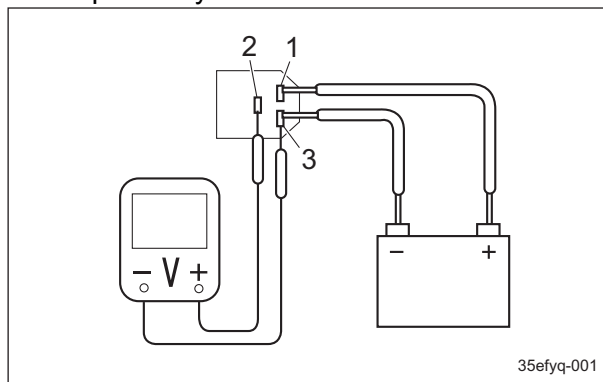

Inspection of Output Voltage_001

1	Connector terminal (white/+)
2	Connector terminal (red/output)
3	Connector terminal (black/-)

Solenoid Valve

Mower Unit Up/Down Valve

The mower unit up/down valve is located in the valve module.

According to the activation of the solenoid valve, the hydraulic circuit in the mower unit up/down valve is switched to control the up/down motion of the mower units.

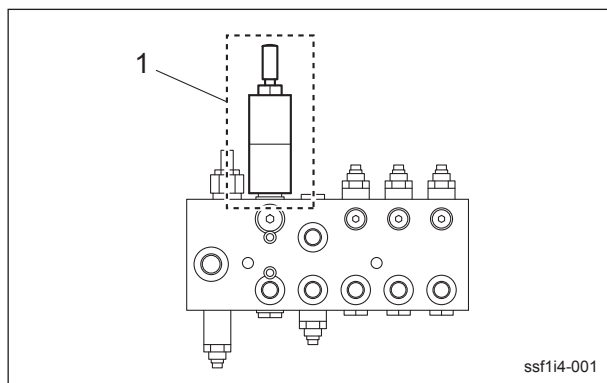

Mower Unit Up/Down Valve_001

1	Solenoid valve
---	----------------

■ Inspection of Solenoid

1. Disconnect the solenoid connectors.
2. Measure the resistance between the connector terminals of the solenoid. Normal operation is when the measured values are as in the table.

■ Solenoid Specifications

Solenoid	Voltage	Resistance	Holding Current
A	DC 12 V	7.6 Ω	1.58 A
B	DC 12 V	7.6 Ω	1.58 A

2WD/3WD Changeover Valve

The 2WD/3WD changeover valve is located in the center of the right side of the body.

It controls the drive wheels. The hydraulic circuit in the 2WD/3WD changeover valve is switched according to the activation of the solenoid valves.

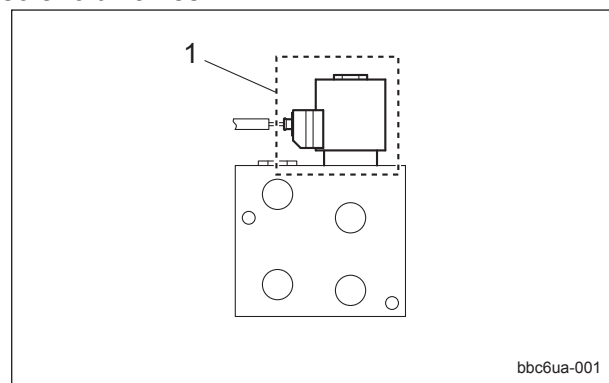

2WD/3WD Changeover Valve_001

1	Solenoid valve
---	----------------

■ Inspection of Solenoid

1. Disconnect the solenoid connectors.
2. The normal resistance between the connector terminals of the solenoid is about 7.1 Ω.

■ Solenoid Specifications

Voltage	Resistance	Holding Current
DC 12 V	7.1 Ω	1.7 A

Mower Unit Control Relay Unit

The motor unit control relay unit controls Up/Down of the mower unit and Rotate/Stop of the reel cutter (cutting cylinder) by the signals from the proximity sensors of reel rotation start position detection and mower up/down position detection.

The operating condition can be confirmed by checking the illumination of the LEDs. Three relay circuits are used inside.

Inspection of Mower Unit Control Relay Unit

1. Remove the mounting bolts of the mower unit control relay unit.
2. Start the engine.

Electrical system

3. Raise and lower the mower units to confirm whether each LED of the mower unit control relay unit is turned on.

If any LED cannot be turned on, follow the following steps to inspect it.

- [1] If the LED of (1) is not turned on, inspect the proximity sensor (reel rotation start position detection) and its peripheral circuit. (Refer to "Adjustment of Reel Rotation Start Position" (Page 5-10) " and "Proximity Sensor" (Page 5-19) ")
- [2] If the LED of (2) is not turned on, inspect the proximity sensor (mower up position detection) and its peripheral circuit. (Refer to "Adjustment of Up/Down Position" (Page 5-10) " and "Proximity Sensor" (Page 5-19) ")
- [3] If the LED of (3) is not turned on, inspect the proximity sensor (mower down position detection) and its peripheral circuit. (Refer to "Adjustment of Up/Down Position" (Page 5-10) " and "Proximity Sensor" (Page 5-19) ")

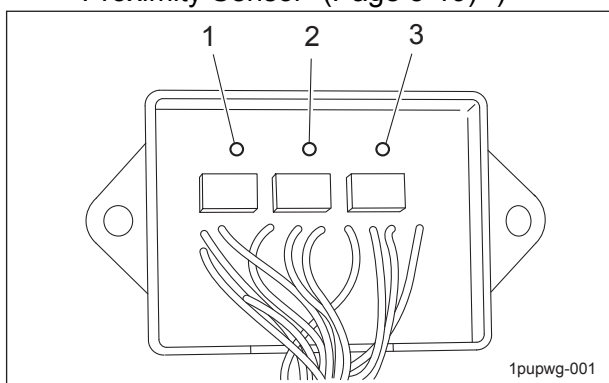

Inspection of Mower Unit Control Relay Unit_001

		Up	Down	Corresponding sensor
1	LED	OFF	ON	Proximity sensor (reel rotation start position detection)
2	LED	ON	OFF	Proximity sensor (mower up position detection)
3	LED	OFF	ON	Proximity sensor (mower down position detection)

4. If there is no abnormality in the parts nor circuit, replace the mower unit control relay unit.
5. Install the mower unit control relay unit.

Interlock Relay Unit

The interlock relay unit controls the operation of a safety device for starting/stopping of the engine by the signals from the proximity switch, parking brake switch, seat switch, proximity sensor (reel rotation switch) and limit switch (back lapping switch).

The operating condition can be confirmed by checking the illumination of the LEDs. Five relay circuits are used inside.

Inspection of Interlock Relay Unit

- Set the key switch to the "ON" position.
- Operate each part to confirm whether each LED of the interlock relay unit can be turned on.

If any LED cannot be turned on, follow the following steps to inspect it.

[1] If the LED of (1) is not turned on, inspect the proximity switch and its peripheral circuit. (Refer to "Neutral Position of Traveling Pedal" (Page 5-12) " and "Proximity Switch" (Page 5-18) ")

[2] If the LED of (2) is not turned on, inspect the parking brake switch and its peripheral circuit. (Refer to "Parking Brake Switch" (Page 5-13) " and "Parking Brake Switch" (Page 5-17) ")

[3] If the LED of (3) is not turned on, inspect the seat switch and its peripheral circuit. (See "Seat Switch" (Page 5-17) ")

[4] If the LED of (4) is not turned on, inspect the proximity sensor (reel rotation switch) and its peripheral circuit. (See "Proximity Sensor" (Page 5-19) ")

- [5] If the LED of (5) is not turned on, inspect the limit switch (back lapping switch) and its peripheral circuit. (Refer to "Adjustment of Back Lapping Switch" (Page 5-13) " and "Back Lapping Switch" (Page 5-19) ")

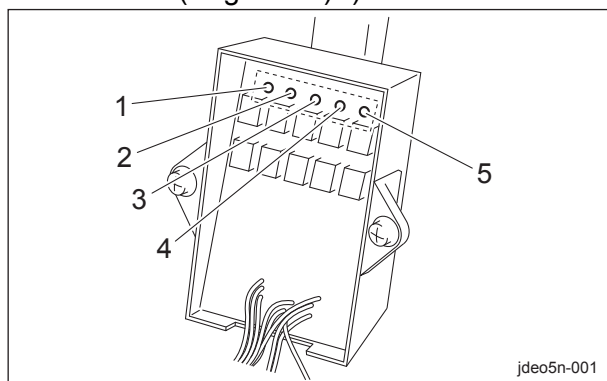

Inspection of Interlock Relay Unit_001

		Condition	LED	Corresponding sensor
1	LED	Neutral	ON	Proximity switch
		Depress	OFF	
2	LED	Pull	ON	Parking Brake Switch
		Release	OFF	
3	LED	Away	ON	Seat switch
		Seated	OFF	
4	LED	ON	ON	Proximity sensor (reel rotation switch)
		OFF	OFF	
5	LED	LAP	ON	Limit switch (back lapping switch)
		H	OFF	
		L	OFF	

3. If there is no abnormality in the parts nor circuit, replace the interlock relay unit.

Electromagnetic Clutch

The electromagnetic clutch is located in the left side of the transmission.

It transmits/blocks the drive of the engine to the transmission by the signals from each sensor and switch.

1. Apply the parking brake.

2. Set the transmission selector lever to the "LAP" position.

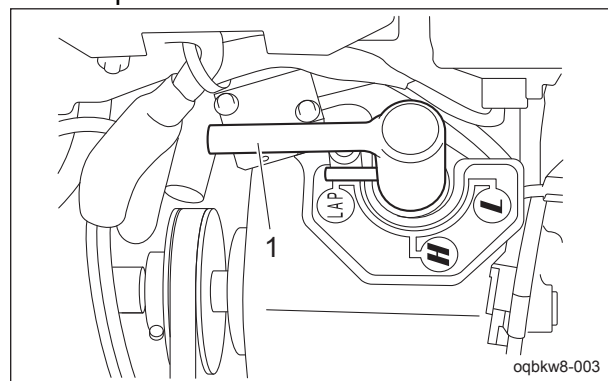

Electromagnetic Clutch_001

1	Transmission selector lever
---	-----------------------------

3. Remove the flexible wire from each mower unit and then hook it on the hook of the mower arm.

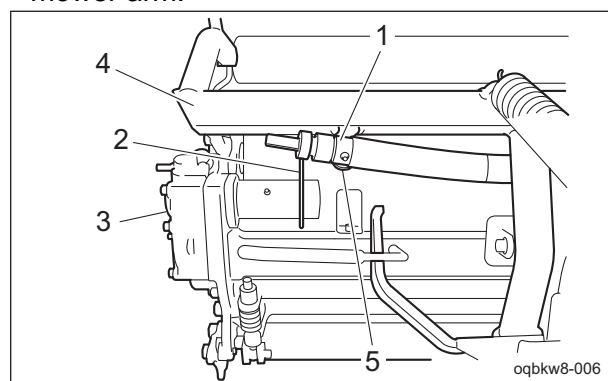

Electromagnetic Clutch_002

1	Flexible wire
2	Clip
3	Mower unit
4	Mower Arm
5	Hook

4. Start the engine.
5. Lower the mower units.
6. Turn "ON" the proximity sensor (reel rotation switch).

Electrical system

7. Make sure that the electromagnetic clutch is connected and the flexible wire drive belt is driven.

Warning

Make sure not to touch the driven belt.

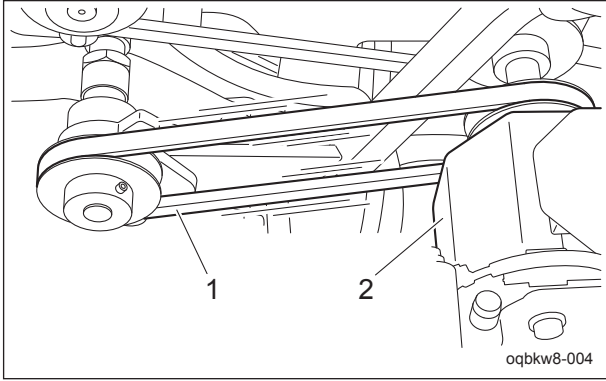

Electromagnetic Clutch_003

1	Flexible wire drive belt
2	Transmission

8. Turn "OFF" the proximity sensor (reel rotation switch).

9. Make sure that the electromagnetic clutch is disconnected and the flexible wire drive belt is not working.

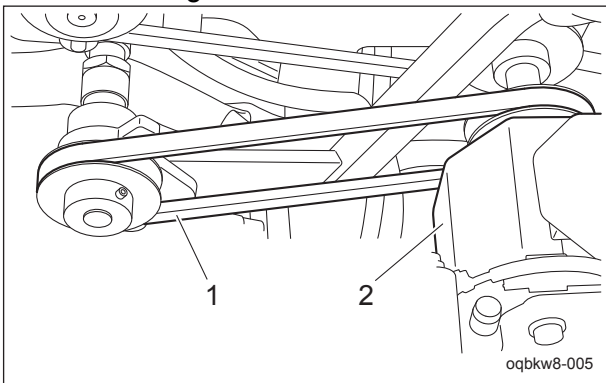

Electromagnetic Clutch_004

1	Flexible wire drive belt
2	Transmission

10. Stop the engine.

11. Install the flexible wire onto each mower unit.

Work Lamp

The work lamp is located on the front part of the machine.

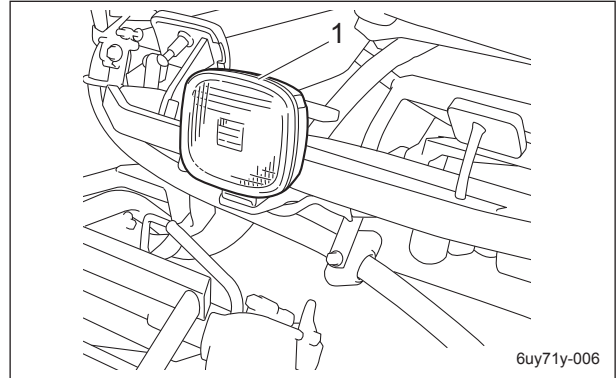

Work Lamp_001

1	Work Lamp
---	-----------

The work lamp lights up and off by operating the toggle switch (light switch).

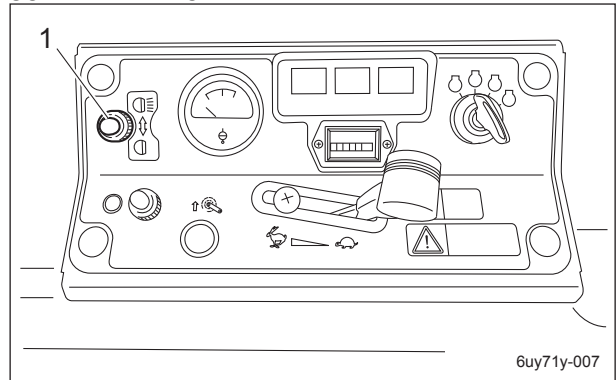

Work Lamp_002

1	Toggle switch (light switch)
---	------------------------------

Note:
Wiring diagram

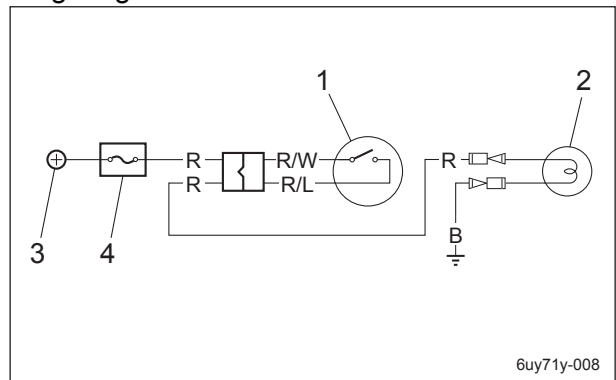

Work Lamp_003

1	Toggle switch (light switch)
2	Work Lamp
3	Battery power
4	Fuse

Valve Specifications

Type	Rating
H3	12 V 55 W

Key switch

Use the key switch to start or stop the engine. The conductive status of each key position is described below.

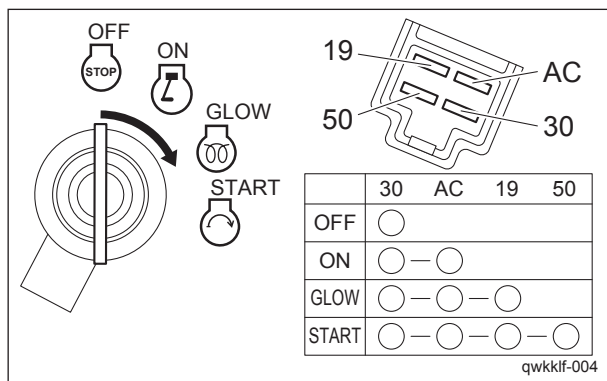

Key Switch_001

Key Position and Device Operation

ON (Run)

The diesel engine on the machine runs or stops based on the fuel supply. If the key position is set to "ON", each part is energized via the fuse from the battery, which makes them operable.

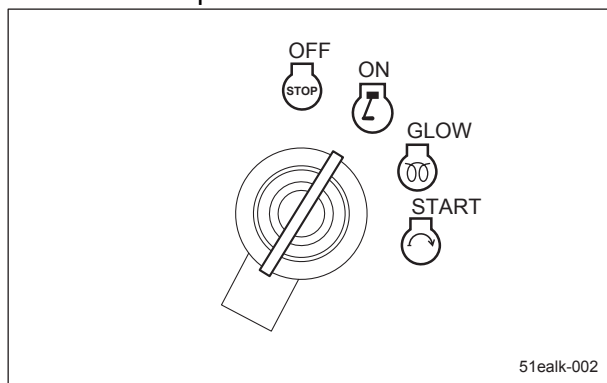

ON (Run)_001

Glow (thermo-start)

When the ignition key is kept in the "GLOW" position, the glow plug is generating heat and the thermo-start lamp is turned on. The lamp turns off at the specified time. However, the lamp turning off is not related to the glow plug generating heat, and the plug is kept heated as long as the key is in "GLOW" position even after the lamp is turned off.

The glow lamp will stay illuminated for five seconds. The glow plug is located at engine head of each cylinder and is connected by the plate. The electrical circuit is grounded at the engine block.

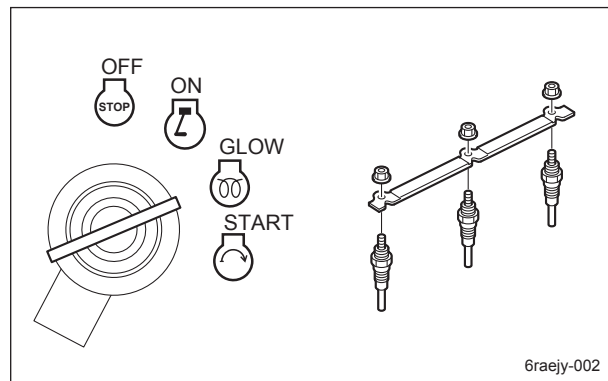

Glow (thermo-start)_001

START

The engine starts by rotating the starter motor, when the magnet switch of the starter motor is energized with the key at "START" position. The starter motor is connected via four safety switches. Only if the engine activation conditions of the interlock system are satisfied, the starter motor can be activated. (See "Interlock System Operation Requirements" (Page 5-9))

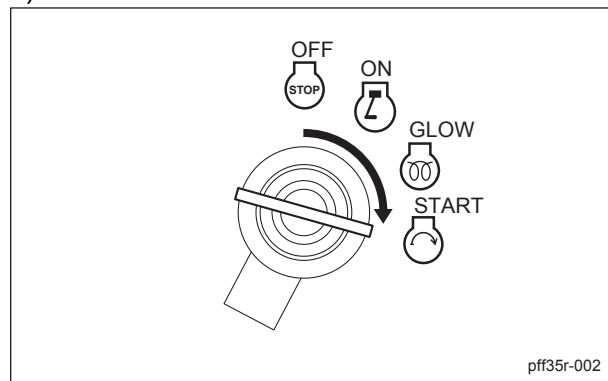

START_001

Electrical system

Pilot lamps

Status of charge of the engine, glow, and oil pressure is displayed with illumination of the lamps.

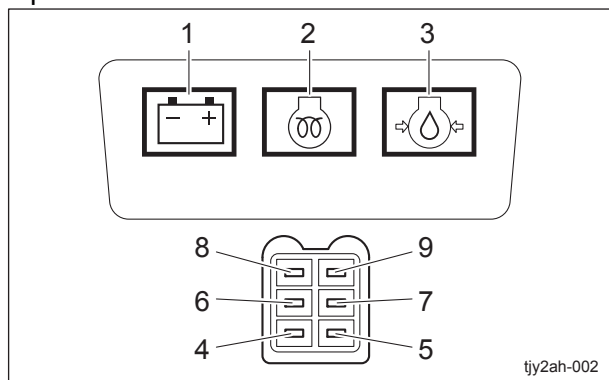

Pilot Lamps_001

1	Charge
2	Thermo-start
3	Engine Oil Pressure
4	Connector terminal (red/charge lamp power)
5	Connector terminal (brown/charge lamp ground)
6	Connector terminal (red/thermo-start lamp power)
7	Connector terminal (white/thermo-start lamp ground)
8	Connector terminal (green/engine hydraulic lamp power)
9	Connector terminal (black/engine hydraulic lamp ground)

Charge

The lamp lights up when the ignition key is set to the "ON" position before the engine starts. It blacks out when the engine starts and the alternator starts operating properly.

If the starter relay is excited with the key position "ON," the regulator internal circuit is conducted and the charge lamp is turned on. If the voltage is supplied from the alternator to the regulator after normal operation, the regulator internal circuit is disconnected and the lamp blacks out.

If the charge lamp lights up during the engine running, a failure in charging may occur due to malfunction of the alternator drive belt, the alternator or the regulator etc.

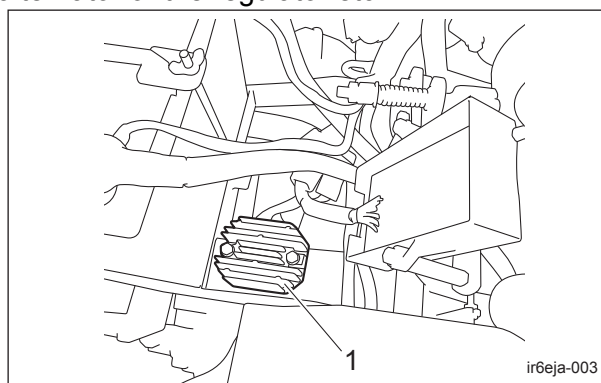

Charge_001

1	Regulator
---	-----------

Thermo-start

When the ignition key is set to the "GLOW" position, it illuminates at the same time when the glow plug generates heat.

Illumination time of the thermo-start lamp is controlled by the glow lamp timer, and the lamp is turned off after a specified amount of time passes.

The duration of illumination indicates an approximate period of time required for warm-up, and has been fixed at five seconds.

Engine Oil Pressure

The lamp turns on when the ignition key is set to the "ON" position before the engine starts. It turns off when the engine starts and engine oil pressure is generated properly.

It is connected to an oil pressure switch located in the engine block (beside the oil element) and lights up if the oil pressure is decreased during operation.

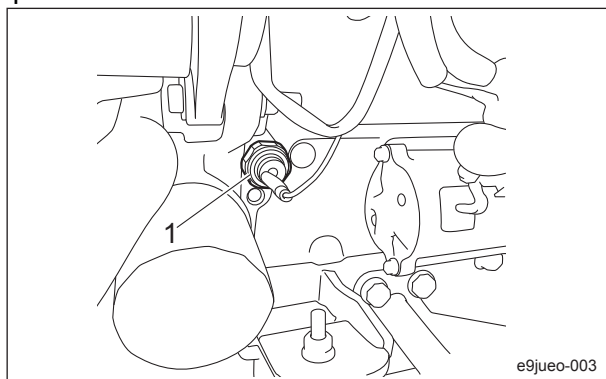

Engine Oil Pressure_001

1	Oil pressure switch
---	---------------------

Water temperature gauge

The water temperature gauge is connected to a water temperature sensor located under the engine thermostat and displays the water temperature.

The resistance value of the water temperature sensor changes according to a temperature and is converted to display the temperature.

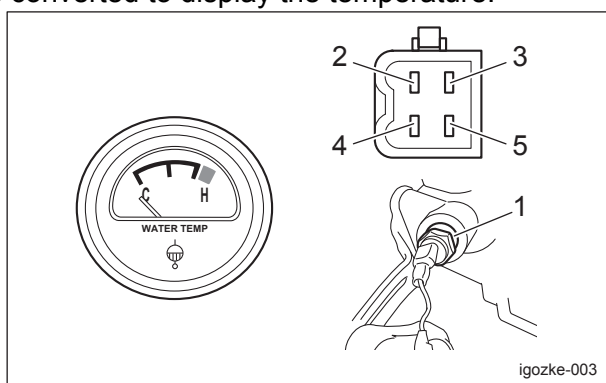

Water Temperature Gauge_001

1	Water temperature sensor
2	Connector terminal (white/water temperature sensor output)
3	Connector terminal (black/ground)
4	Connector terminal (yellow/light) (not in use)
5	Connector terminal (red/IGN)

Hour meter

The hour meter is located in the operation panel, and indicates the accumulated operation time of the engine.

The number in black figures on a white background is incremented every six minutes.

The number in white figures on a black background is incremented every hour. 1/10 wheel ... black figures on a white background

Hour wheel ... white figures on a black background

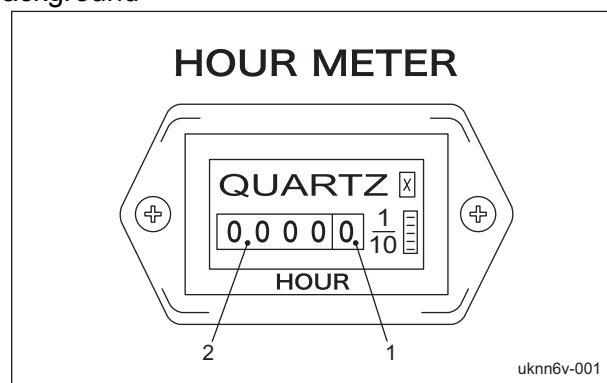

Hour meter_001

1	1/10 wheel
2	Hour wheel

Starter Relay

The starter relay is located in the left side of the hydraulic tank and controls the activation of the starter motor.

Only if the engine starting conditions of the interlock system are satisfied, the starter motor can be activated. (See "Interlock System Operation Requirements" (Page 5-9))

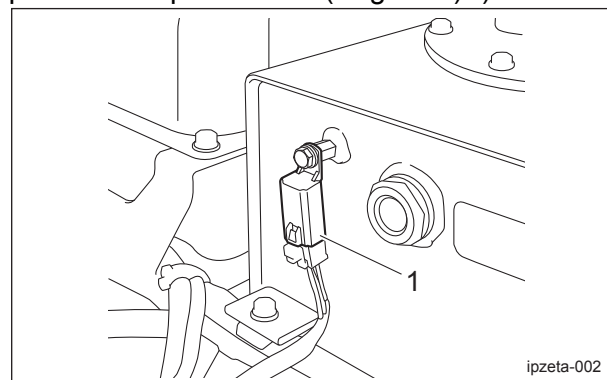

Starter Relay_001

1	Starter relay
---	---------------

Electrical system

Glow Lamp Timer

The glow lamp timer is located in front of the valve module and controls illumination of the thermo-start lamp.

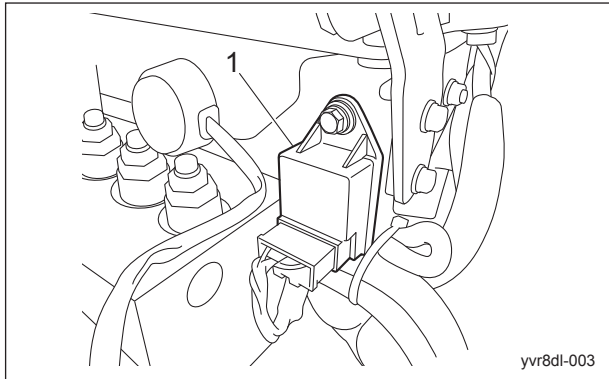

Glow Lamp Timer_001

1	Glow lamp timer
---	-----------------

When the ignition key is set and held to the "GLOW" position, the thermo-start lamp turns on for 5 seconds.

The timer unit is activated with the "GLOW" and "START" signals from the ignition key switch. When the glow signal is input, the thermo-start lamp turns on (5 seconds).

When the ignition key is set to the "START" position (starter motor start), even during the period of the thermo-start lamp turning on (before 5 seconds pass), the starter start signal is input and the lamp is turned off.

If the timer unit malfunctions, the lamp will not turn on; however, this will not affect engine starting.

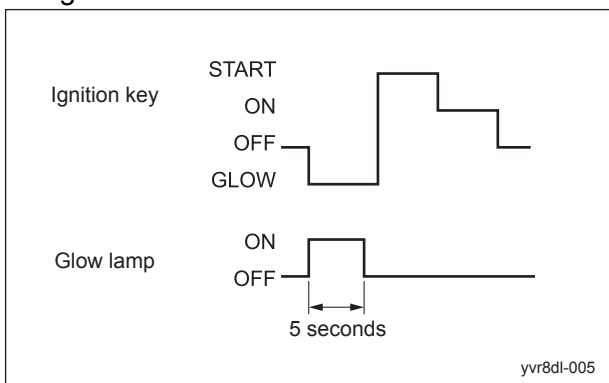

Glow Lamp Timer_002

Fusible Link

The fusible link acts as a main fuse for the entire circuit and a fuse for the charging circuit. Located in the right hood, it is equipped with a specialized fuse (50 A) cartridge.

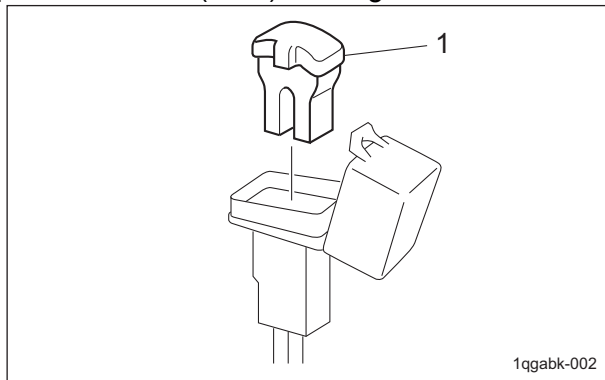

Fusible Link_001

1	Specialized fuse
---	------------------

Fuse box

Respective electrical equipments are connected from the key switch through fuses in the fuse box which is located in front of the fuel tank. Fuse standards are "mini fuses for automobiles".

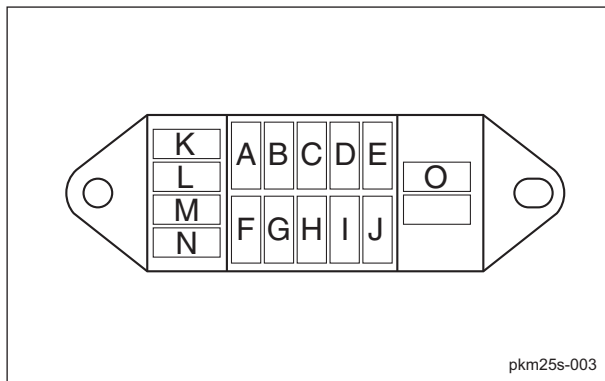

Fuse Box_001

A	5 A	Glow lamp timer
B	5 A	Key stop timer
C	5 A	Glow lamp timer, glow lamp (thermo-start lamp)
D	-	-
E	-	-
F	15 A	Engine stop solenoid
G	15 A	Others
H	5 A	Water temperature gauge, regulator
I	-	-
J	-	-
K	5 A	Spare
L	5 A	
M	15 A	
N	15 A	
O	Fuse removal tool	

Replacement of Fuse

The fuse box includes spare fuses and tools.

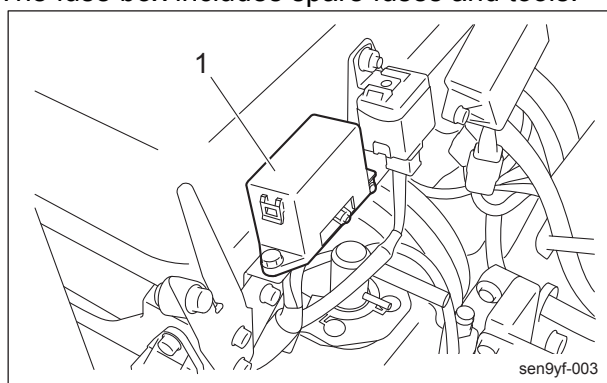

Replacement of Fuse_001

1	Fuse box
---	----------

Buzzers

Buzzers work as a water temperature warning, hydraulic oil level warning, and parking brake warning.

With the circuit in this machine, the engine will not stop, even if any buzzers sound.

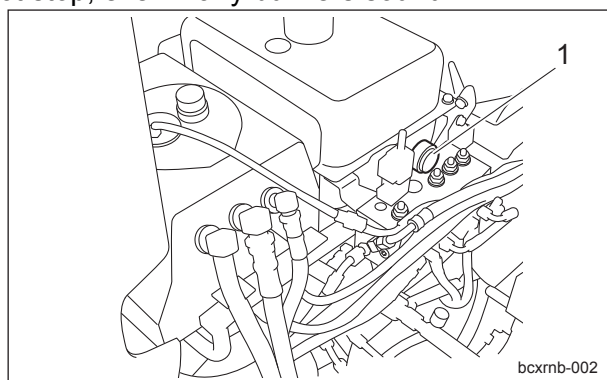

Buzzers_001

1	Buzzers
---	---------

1. The water temperature buzzer is a warning buzzer for the engine water temperature connected to the thermo switch on the engine.

If the water temperature inside the engine exceeds 105 degrees C (221 degrees F), the thermo switch is conducted with the engine block and a buzzer will sound. [intermittent tone]

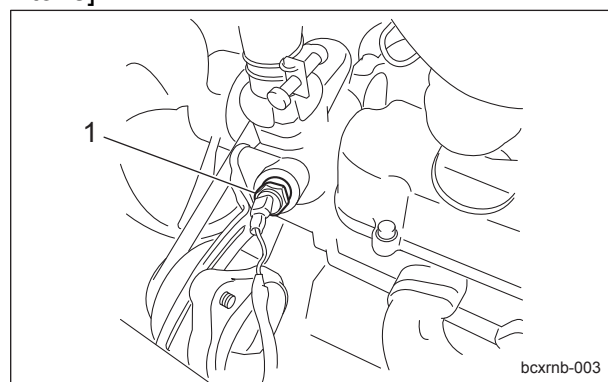

Buzzers_002

1	Thermo switch
---	---------------

2. The hydraulic oil level warning is a buzzer that warns about insufficient oil and is connected to the level switch on the hydraulic tank.

If the hydraulic oil level declines from the specified level by approximately 1.2 dm³ (1.2 L) (0.32 U.S.gals), the internal circuit of the level switch is conducted and a buzzer will sound [intermittent tone].

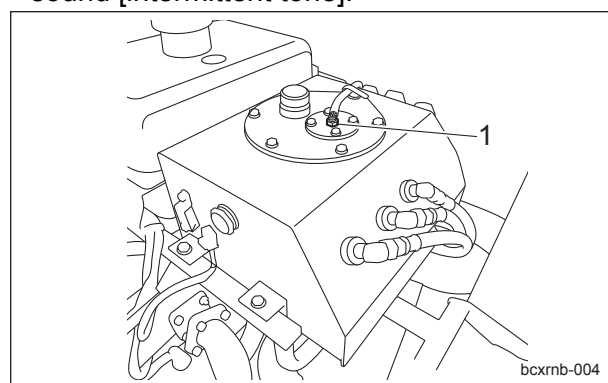

Buzzers_003

1	Level Switch
---	--------------

Electrical system

3. The parking brake warning is connected to the parking brake switch and proximity switch via the interlock relay unit. If you hit the traveling pedal with sitting on the seat while the parking brake is applied, the internal circuit of the interlock relay unit is conducted and a buzzer will sound [intermittent tone].

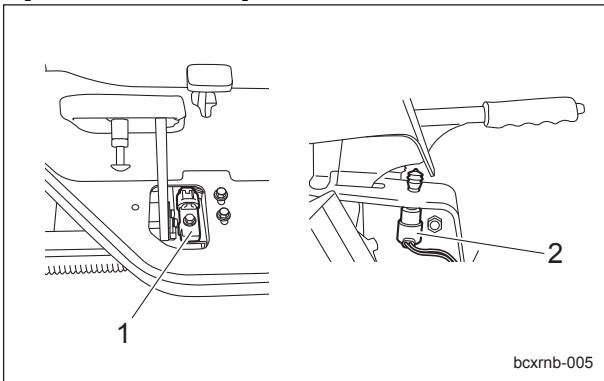

Buzzers_004

1	Proximity Sensor
2	Parking Brake Switch

Level Switch

The level switch is located at the top of the hydraulic tank, and switches ON and OFF according to the rise and fall of the float. (The arrow indicates the float travel distance.) It is normal if there is conduction when the float is down, and no conduction when the float is up.

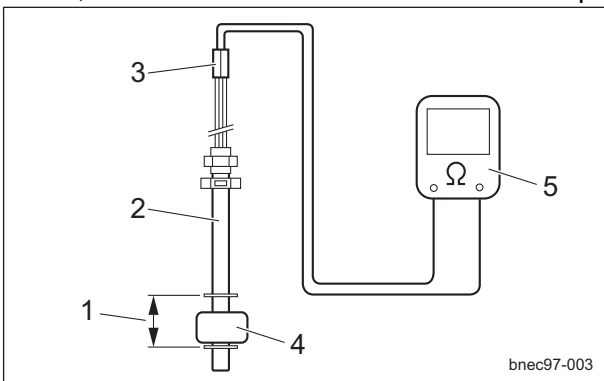

Level Switch_001

1	Float travel distance
2	Level Switch
3	Connector
4	Float
5	Circuit tester

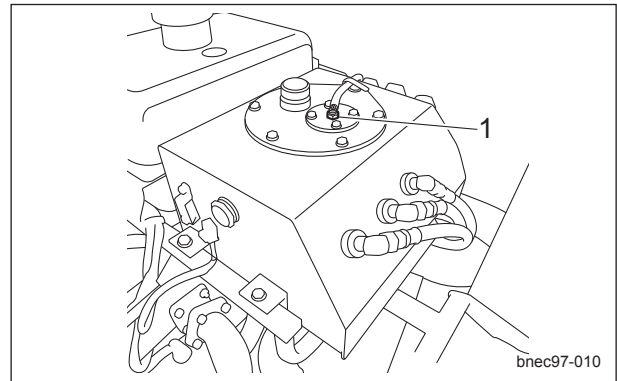

Level Switch_002

1	Level Switch
---	--------------

General inspection and repair

Battery

Handling of the battery

For details on handling the battery, please refer to the separate Battery Instruction Manual. For safe use of the battery, observe the following precautions:

⚠ Danger

Do not use the battery near open flames or in a poorly ventilated area. Keep the battery away from lit cigarettes and other open flames.

Do not short-circuit the battery.

If the positive and negative terminals are connected to each other by a metallic tool, the battery will short-circuit. And a short-circuit will also occur if the positive terminal contacts another metallic part (machine body etc.).

1. Keep the battery away from open flames. Hydrogen gas may be generated from the battery. Improper handling of the battery could cause a fire or explosion.

⚠ Danger

Do not throw, drop, tilt or upset the battery, or allow it to undergo physical impact.

Doing so could cause the electrolyte to leak. If contact of the electrolyte with the eye, skin, or clothing occurs, immediately wash it off with plenty of water.

In particular, if eye contact or ingestion occurs, immediately seek medical treatment. If the electrolyte spills over the machine etc., wipe away with a wet cloth and flush the affected area with plenty of water.

2. The electrolyte contained in the battery is sulfuric acid.
Contact of the electrolyte (sulfuric acid) with the skin could cause blindness or burns.
Contact of the electrolyte with the machine etc. could cause damage to the machine.

⚠ Danger

Do not allow anyone to handle the battery who does not fully understand the correct battery handling procedures and relevant dangers.

When handling the battery, wear protective glasses and rubber gloves, etc.

If the battery has an unusual odor, if the electrolyte level goes down unusually fast, or if the electrolyte leaks, do not continue to use the battery.

Failure to observe these precautions could cause a fire, explosion, etc.

⚠ Caution

If the electrolyte overflows, neutralize it with bicarbonate etc. until the bubbles disappear, and wash out with plenty of water.

Failure to do so could cause corrosion of the surrounding area or environmental pollution.

If deformation of the exterior of the battery is observed, do not continue to use it.

Doing so could result in damage to the battery or electrolyte leaks.

3. Use extra care when handling the battery, and if any problems are found, replace the battery with a new one.
Carry or store the battery with care so that it does not fall or become damaged.

Inspection of the battery

To ensure safe use of the battery, inspect it at least once a month.

Before inspecting the battery, be sure to stop the engine and remove the key.

⚠ Danger

Do not allow anyone to handle the battery who does not fully understand the correct battery handling procedures and relevant dangers.

When handling the battery, wear protective glasses and rubber gloves, etc. The electrolyte may cause blindness or burns. Never use an open flame when inspecting the battery.

Do not connect the positive and negative battery terminals to each other using a metallic tool etc.

Doing so could cause a fire or explosion.

Always keep the electrolyte level above the LOWER (minimum level line) limit.

Failure to do so could cause the battery life to be shortened or cause explosion.

Loose connections between cable and terminal, or corroded terminals could cause a fire or explosion.

⚠ Warning

Before handling the battery such as for purposes of inspection etc, touch a metal part of the machine body with your bare hand in order to remove static electricity.

Static electricity could cause a fire.

When cleaning the battery, do not use dry cloth or tissue paper, etc.

Static electricity could cause a fire.

When adding distilled water, keep the electrolyte level below the UPPER (maximum level line) limit.

Failure to do so could cause the electrolyte to leak.

Electrical system

⚠ Caution

If the electrolyte overflows from the battery, wipe it with a wet cloth.

Failure to do so could cause damage to the instruments.

When cleaning the battery, do not use organic solvents such as benzene, thinner or gasoline and refrain from using cleaner, or chemical cloth.

Doing so could damage the battery case, resulting in electrolyte leaks.

Do not add anything but distilled water to the battery.

Adding anything other than distilled water could cause the battery to become extremely hot or generate toxic gases due to impurities.

Do not add sulfuric acid to the battery.

Doing so could cause the specific gravity of the electrolyte to exceed the specified value, causing the battery life to be shortened.

After adding distilled water to the battery, firmly tighten the vent plug.

When inspecting the battery, inspect the following items:

1. Visual inspection

Visually inspect the battery case for cracks, chips and deformation, and check that there are no electrolyte leaks.

If any of the above are found, investigate what has caused them and replace the battery.

2. Cleaning of the exterior

When cleaning the battery, use cloth that has been dampened with water.

Inspect the vent plug or vent hole on the side.

If the plug or hole is clogged with mud etc., wash it with water.

A clogged vent hole could cause the internal pressure to increase due to gases generated inside the battery, causing the battery to burst.

3. Inspection of the mounting bracket

Ensure that the battery is firmly secured by the mounting bracket.

If it is not, tighten the nuts securing the battery until it is firmly secured.

If the battery is not firmly secured by the mounting bracket, the battery could move due to vibration while the machine is moving, resulting in damage to the battery case or electrolyte leaks.

4. Inspection of the cable terminals for looseness

If a connection between a battery terminal and machine-side cable terminal is loose, tighten the nut securing the cable terminal until it is firmly secured.

Loose connections could result in an insufficiently charged battery, damaged terminals, or explosion.

Note:

If a terminal has corroded, polish it using a wire brush or fine sandpaper, and apply a small amount of anti-rust grease.

Important

When adding distilled water, be careful not to add an excessive amount.

5. Inspection of the electrolyte level and addition of distilled water

Check the electrolyte level by looking from the side of the battery.

If the electrolyte level has fallen to less than halfway between the "UPPER" (maximum level line) and "LOWER" (minimum level line) limits, add distilled water to the battery immediately until the "UPPER" limit is reached.

When adding distilled water, loosen and remove the vent plug and add distilled water up to the "UPPER" (maximum level line) limit.

After adding distilled water, firmly tighten the vent plug.

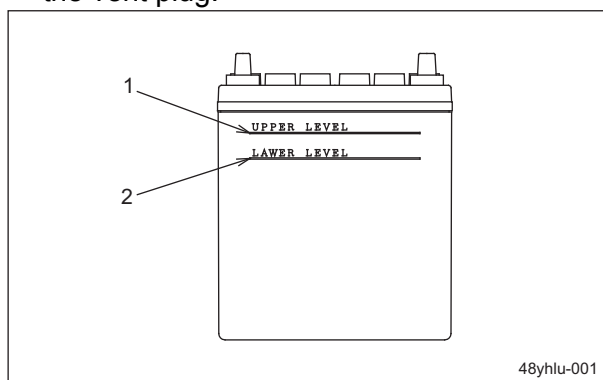

48yhtu-001

Inspection of the battery_001

1	Upper limit
2	Lower limit

Replacement of Battery

When replacing the battery, note the following precautions and be sure to turn off the power switch etc., stop the engine, and remove the key before replacement.

! Danger

Do not replace the battery near open flames or in a poorly ventilated area. Keep the battery away from lit cigarettes and other open flames.

Failure to observe these precautions could cause a fire or explosion.

Do not short-circuit the battery.

If the positive and negative terminals are connected to each other by a metallic tool, the battery will short-circuit. And a short-circuit will also result if the positive terminal contacts another metallic part (machine body etc.).

When connecting a machine-side cable terminal to a battery terminal, ensure that the nut is firmly tightened.

A loose nut could cause a fire or explosion.

! Warning

When connecting the machine-side cable terminals to the battery, ensure that they are correctly connected to the positive and negative terminals.

Secure the battery firmly with the mounting bracket.

Failure to do so could cause damage to the battery, leakage of the electrolyte, fire or explosion.

Do not modify the battery terminals.

Ensure that the vent plug or vent hole on the side of the battery is not covered by the connection cables etc.

Do not connect any electrical devices directly to the battery.

! Caution

Select a battery that has the same terminal positions (the positions of the positive and negative terminals) as the old one. Installing a battery that has different terminal positions could cause damage to the cables. Do not use organic solvents such as benzene, thinner or gasoline and refrain from using cleaners.

Do not allow the battery to come in contact with vinyl chloride containing plasticizer etc. When handling the battery, keep it in a horizontal position and install it on the mounting so that it is horizontal.

If the battery has terminal covers or heat shield plates attached, re-install them in their original positions after replacing the battery. When mounting the battery on the machine, never hold the battery terminals.

Doing so could cause the terminals to deform, resulting in poor connections or electrolyte leaks from around the terminals. Replace the battery with one that is the same size.

When replacing the battery, follow these steps:

Removing the old battery

Important

Be careful when handling the used battery as it still contains electrical energy.

- [1] Stop the engine and remove the key.
- [2] Disconnect the negative cable.
- [3] Disconnect the positive cable.
- [4] Loosen the mounting bracket and remove the old battery.

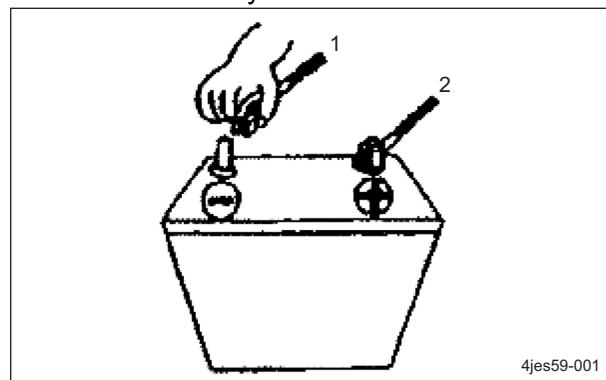

4jes59-001

Replacement of Battery_001

1	(-) Cable
2	(+) Cable

Electrical system

Installing a new battery

- [1] Install the new battery with the correct polarities and firmly secure the battery with the mounting bracket.

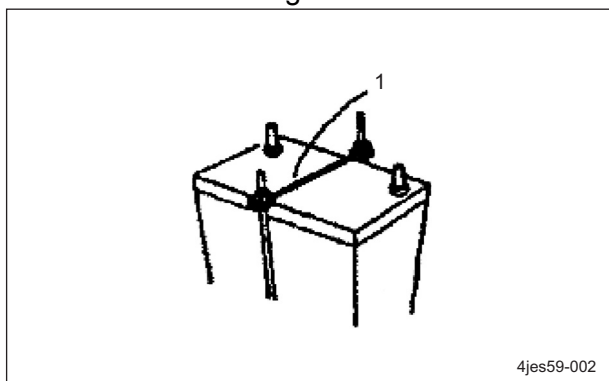

Replacement of Battery_002

1	Mounting bracket
---	------------------

- [2] Remove the protection cap from the new battery.
 [3] Firmly secure the positive cable to the positive terminal.
 [4] Firmly secure the negative cable to the negative terminal.

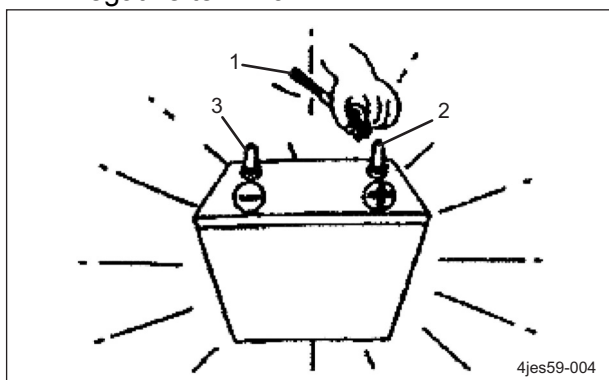

Replacement of Battery_003

1	(+) Cable
2	(+) Terminal
3	(-) Terminal

Battery Charge

When charging the battery with the battery charger, follow the correct steps according to the handling instructions attached to the battery charger.

⚠ Danger

Do not charge the battery near open flames or in a poorly ventilated area. Keep the battery away from lit cigarettes and other open flames.

Failure to observe these precautions could cause a fire or explosion.

Do not connect the charge clip to the battery nor remove it while the power of the battery charger is ON.

Failure to observe these precautions could cause a fire or explosion.

If the battery charger has a changeover switch for voltage, set the battery voltage for charge.

If the voltage for charge is wrong, it may cause overheating or ignition of the battery charger or explosion of the battery.

 Warning

Charging the battery mounted on the vehicle may cause ignition, explosion, or damage on the vehicle or equipment.

If there is no way other than to charge the battery mounted on the vehicle, remove the minus cable terminal on the vehicle side, which is connected to the battery.

When connecting to the battery charger, firmly connect the plus and minus charge clip to the plus and minus terminals of the battery, respectively.

If they are connected reversely or loosely, it may cause ignition, explosion, failure of the battery charger, or damage on the vehicle or equipment due to the polarity inversion of the battery.

Set the charging current to 1/10 or less than the rating capacity of battery. In the case of fast charging, set it to that rating capacity or less.

If the charging current is too large, it may cause ignition or explosion due to electrolyte leaks or liquid shortage.

Do not mount the battery on the vehicle and wait for 30 minutes after charging.

Failure to observe these precautions could cause a fire or explosion.

Important

Fast charging is not suitable for charging to recover the battery left for a long time.

A high electrolyte temperature deteriorates parts such as polar plates inside the battery and shorten its lifetime.

 Caution

The temperature of the electrolyte must be 45 degrees C or lower. In the case of fast charging, it must be 55 degrees or lower.

If these temperature limits are exceeded, it could result in battery deformation or electrolyte leaks.

When charging the battery, remove the vent plug of the battery, if possible, to expedite the diffusion of the hydrogen gas derived from the battery.

Electrolytic solution adheres to the vent plug, so be careful so that your skin nor clothes do not touch the solution.

If the electrolyte level is lower than halfway between the solution levels, add purified water up to the UPPER LEVEL (maximum line).

If UPPER LEVEL is exceeded, it may cause electrolyte leaks.

Electrical system

Maintenance..... Page 6-2

About Maintenance.....Page 6-2

Specifications..... Page 6-2

Tire pneumatic pressure..... Page 6-2

Adjusted Value..... Page 6-2

Special Tool.....Page 6-2

List of Special Tools.....Page 6-2

Adjustment..... Page 6-3

Brake..... Page 6-3

Adjusting the Neutral Position of the
Piston Pump..... Page 6-3

Throttle wire.....Page 6-4

Main body

Maintenance

About Maintenance

This chapter provides descriptions of the main inspection and maintenance procedures for the LM315GC.

For daily inspections and maintenance as well as machine handling, refer to the LM315GC Operator's Manual and Parts Catalog.

Specifications

Tire pneumatic pressure

	kPa	kgf-cm ²	psi=lb-in
Front wheel	80	0.8	11.60
Front wheel (Option)	100	1.0	14.50
Rear wheel	80	0.8	11.60

Adjusted Value

		mm	in
Spring compression distance (neutral adjustment rod part)	Compression spring	55.0	2.17
Parking brake wire part	Brake drum side clearance	1.0	0.04
Throttle wire part	Engine side clearance	1.0	0.04

Adjusted Value of Parking Brake Wire

The clearance adjusted value of brake wire on the brake drum side is described below.

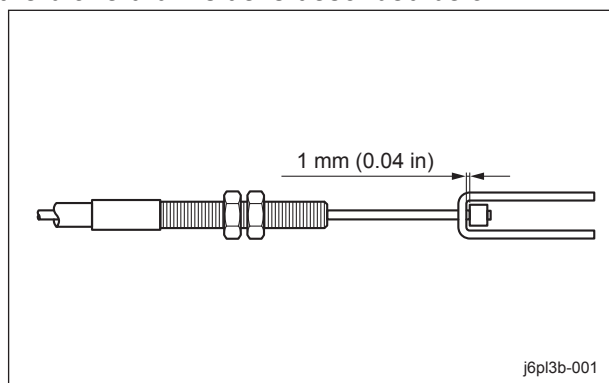

Adjusted Value of Parking Brake Wire_001

Adjusted Value of Throttle Wire

The adjusted value of clearance of engine side throttle wire part is described below.

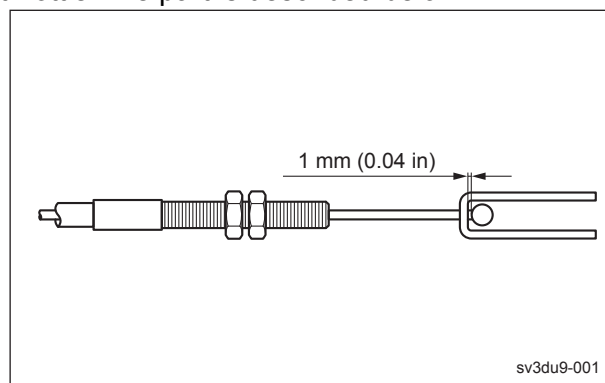

Adjusted Value of Throttle Wire_001

Special Tool

List of Special Tools

No special tool is required.

Adjustment

Brake

Adjustment of Parking Brake Wire

! Danger

Make sure that the brake wire is not cracked or damaged.

Make sure that the brake is effective on slopes and that it is not applied any longer when you release it.

Adjust the parking brake system whenever there is any abnormality.

Adjust the parking brake system by the adjustment bolt on brake drum side at first.

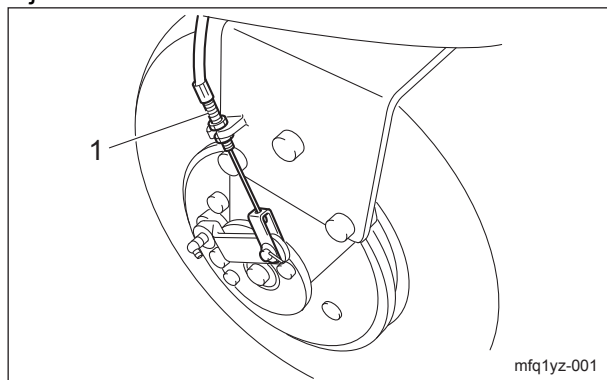

Adjustment of Parking Brake Wire_001

1	Adjustment bolt (on brake drum side)
---	--------------------------------------

1. Follow the steps below to adjust the parking brake.

[1] Tighten the lever-side adjuster bolt of the parking brake wire to the maximum extent.

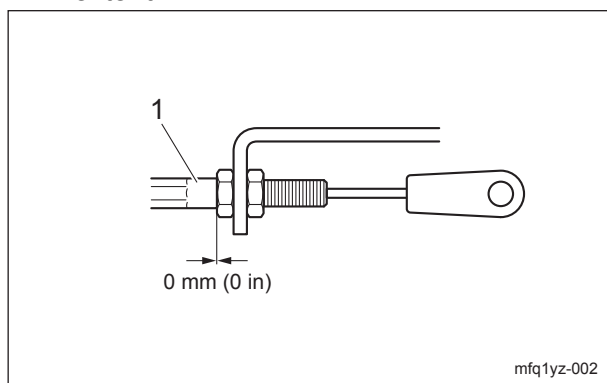

Adjustment of Parking Brake Wire_002

1	Parking brake wire
---	--------------------

[2] Pull the parking brake lever to engage the latch on the notch.

[3] Adjust it by the adjustment bolt so that the latch is located at 4 to 5 notches when the parking brake lever is pulled to the maximum extent.

[4] If you cannot adjust it just by the adjustment bolt on the brake drum side, adjust it by the adjustment bolt on the parking brake lever side.

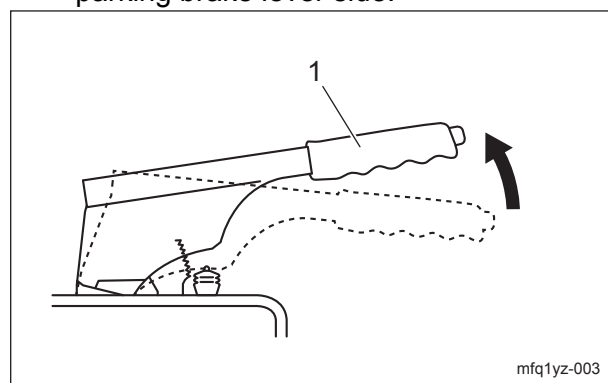

Adjustment of Parking Brake Wire_003

1	Parking Brake Lever
---	---------------------

Adjusting the Neutral Position of the Piston Pump

! Caution

Make sure not to touch rotating tires. When adjusting the neutral position, pay close attention to abrupt start of the machine. Place the jacks beneath the jack-up points, and then lift the machine up until all the tires get off the ground.

If the machine moves forward or backward while the traveling pedals are released, they are not set to the neutral position.

Follow the steps below to make adjustments.

1. Stop the engine.

Main body

- Remove the cotter pin and washer at the pedal end, and then remove the end of the push-pull cable.

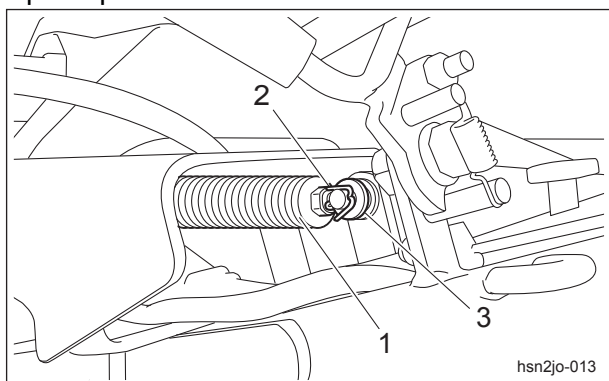

Adjusting the Neutral Position of the Piston Pump_001

1	Push-pull cable
2	Cotter pin
3	Washer

- Place the jacks beneath the jack-up points, and then lift the machine off the ground. (See "Jack-up Points" (Page 3-10) .)
- Make sure that no tires get contact with the jack stand.
- Start the engine, and rev it up to the maximum rpm.
- Adjust the neutral position.
 - Loosen the lock nut.
 - Rotate the camshaft slowly until the front wheel stops. Find the position where the front wheel stops and lock the camshaft with the nut.

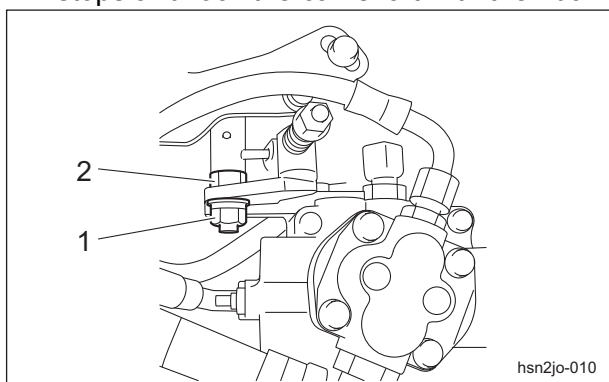

Adjusting the Neutral Position of the Piston Pump_002

1	Lock nut
2	Cam shaft

- Insert the push-pull cable, and then install the washer and cotter pin.

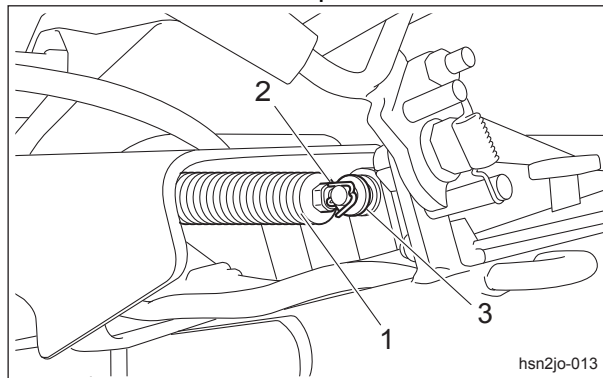

Adjusting the Neutral Position of the Piston Pump_003

1	Push-pull cable
2	Cotter pin
3	Washer

Throttle wire

Adjustment of Throttle Wire

Movement of the lever may become dull, play of the inner wire depending on R angle of the outer wire may change, and the inner wire may be stretched due to frequent use. Inspect it and, if necessary, implement adjustment etc.

- Remove the operation panel cover.
- Tighten nut B in the position where the tip of the lever-side adjuster bolt of the throttle wire fits with the edge face of nut A.

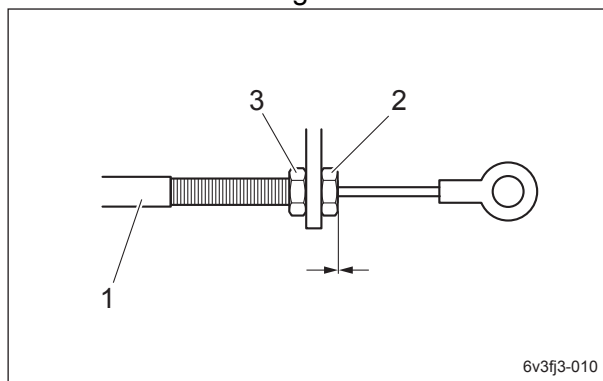

Adjustment of Throttle Wire_001

1	Throttle wire
2	Nut A
3	Nut B

- Install the operation panel cover.
- Move the throttle lever to Low side until it contacts the cover.

5. Adjust the clearance of the joint part to 1.0 mm (0.04 in) with the engine-side adjustment bolt of the throttle wire, and tighten the nut.

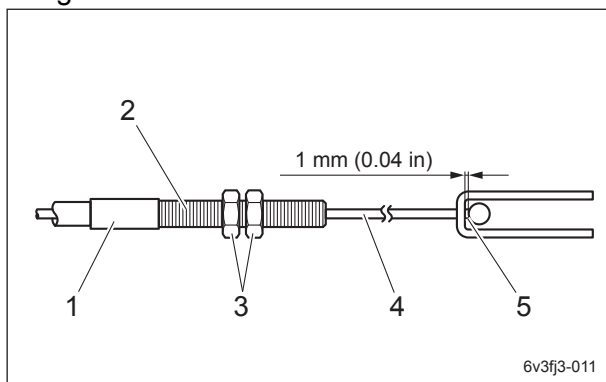

Adjustment of Throttle Wire_002

1	Throttle wire (outer)
2	Adjustment bolt
3	Nut
4	Inner wire
5	Joint part

7. Make sure that there is clearance between the stopper for maximum rpm of the engine side and the throttle lever. If there is no clearance, adjust the position of the stopper bolt on the operation panel.

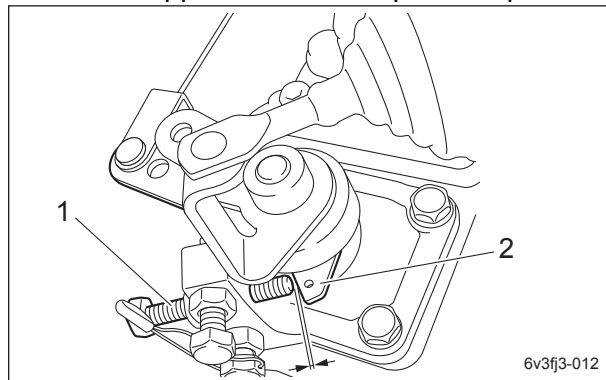

Adjustment of Throttle Wire_004

1	Stopper for maximum rpm
2	Throttle lever

6. Move the throttle lever on the operation panel to the position where it touches the stopper bolt.

Note:

If the throttle lever touches the stopper bolt, the maximum engine rpm is applied.

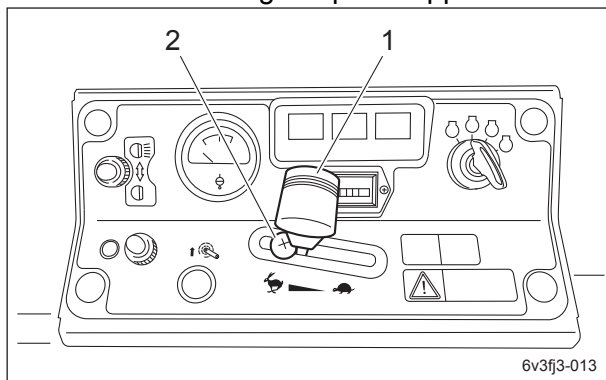

Adjustment of Throttle Wire_003

1	Throttle lever
2	Stopper bolt

Operating Machine and Mower Units

Maintenance.....	Page 7-2	CR Brush.....	Page 7-43
About Maintenance.....	Page 7-2	Groomer Assy.....	Page 7-44
Specifications.....	Page 7-2		
Grease.....	Page 7-2		
Adjusted Value.....	Page 7-2		
Special Tool.....	Page 7-3		
List of Special Tools.....	Page 7-3		
Usage.....	Page 7-5		
Bearing Driver.....	Page 7-5		
Oil Seal Installer.....	Page 7-5		
Adjustment.....	Page 7-6		
Adjustment of Blade Engagement.....	Page 7-6		
Collimating.....	Page 7-6		
Cutting Height Adjustment.....	Page 7-8		
Adjustment of Groomer Height.....	Page 7-8		
Adjustment of Cutter Adjustment Spring.....	Page 7-8		
Removal and installation of each section.....	Page 7-8		
Mower unit.....	Page 7-8		
Groomer Assy.....	Page 7-9		
Bed Knife Mounting Assy.....	Page 7-10		
Reel Cutter.....	Page 7-13		
Front Roller Assy.....	Page 7-16		
Rear Roller Assy.....	Page 7-19		
Grass catcher roller.....	Page 7-20		
CR Brush Driver.....	Page 7-21		
Inspection and repair of each section.....	Page 7-22		
Reel cutter.....	Page 7-22		
Reel Housing.....	Page 7-23		
One-shaft Housing.....	Page 7-25		
Transmission Gear.....	Page 7-29		
Bed Knife.....	Page 7-30		
Roller.....	Page 7-31		
Mower Mounting Bracket.....	Page 7-40		
CR Brush Driver.....	Page 7-41		

Operating Machine and Mower Units

Maintenance

About Maintenance

This chapter describes primary checking and maintenance operations for the LM315GC mower unit.

For information on daily checks, maintenance and handling of the machine, please refer to the separate LM315GC Owner's Operating Manual and Parts Catalog.

For information on attaching and removing optional parts and attachments, please refer to the handling manual for the corresponding attachment.

Specifications

Grease

Use the following type of grease on the operating machine and mower units.

Grease	Excelite EP No. 2 (urea base)
	Moly speed grease No.2 (Flexible wire only)

Adjusted Value

Spring compression distance	Cutter adjustment spring	26.0 mm	1.02 in
Rod distance (From the center of the rod end to the end of the ball joint holder)	Mower mounting bracket	100.0 mm	3.94 in

Operating Machine and Mower Units

Special Tool

List of Special Tools

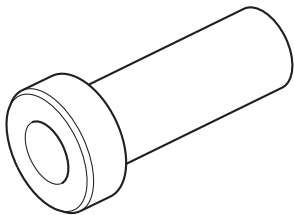
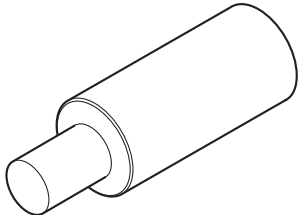
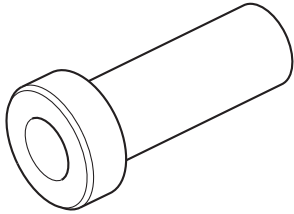
<p>6303 Bearing driver</p>  <p style="text-align: right;">q9c6v6-009</p>	<p>K4802000752</p>	<p>Used when installing bearings with outer $\Phi 47$ and inner $\Phi 17$</p>
<p>Needle TAF212920 Bearing driver</p>  <p style="text-align: right;">q9c6v6-033</p>	<p>K4802000852</p>	<p>Used when installing the needle bearings and oil seals of the mower unit one-shaft housing.</p>
<p>6003 Bearing driver</p>  <p style="text-align: right;">q9c6v6-009</p>	<p>K4802000842</p>	<p>Used when installing bearings with outer $\Phi 35$ and inner $\Phi 17$.</p>

Operating Machine and Mower Units

6205 Bearing driver

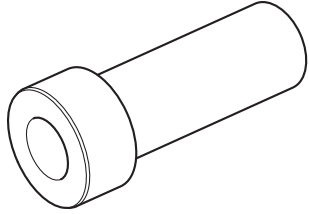

q9c6v6-010

K4802000822

Used when installing the bearing of
outer $\Phi 52$ and inner $\Phi 25$

Operating Machine and Mower Units

Usage

Bearing Driver

Use bearing drivers to drive in bearings etc. accurately.

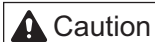

Be careful not to hit your hand with a hammer etc.

1. Place the bearing driver so as to contact it at right angle to the face of bearing.

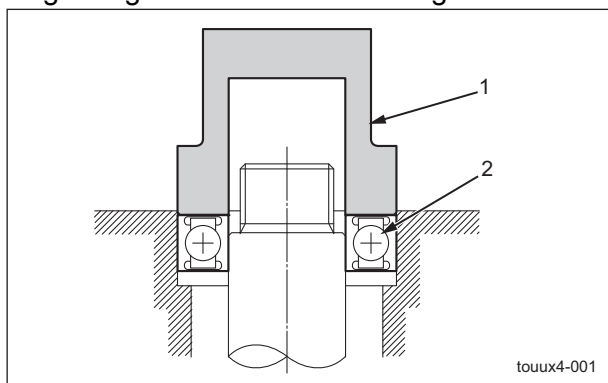

Bearing Driver_001

1	Bearing Driver
2	Bearing

2. Hold the bearing driver securely with hand and drive in with a hammer etc.

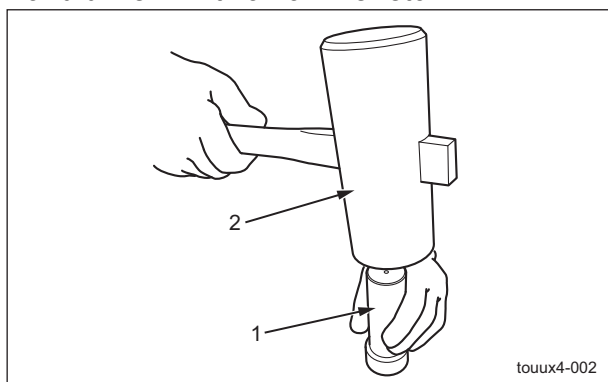

Bearing Driver_002

1	Bearing Driver
2	Hammer

Oil Seal Installer

Use an oil seal installer to install the oil seal etc. correctly.



Be careful not to hit your hand with a hammer etc.

1. Position the oil seal installer so that it is perpendicular to the surface of the oil seal.

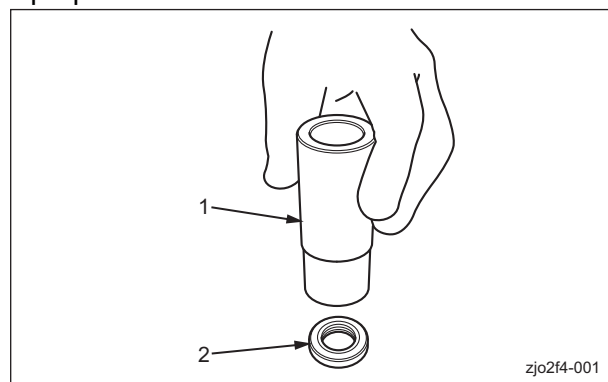

Oil Seal Installer_001

1	Oil Seal Installer
2	Oil seal

2. Firmly hold the oil seal installer, and then hit it with a hammer etc.

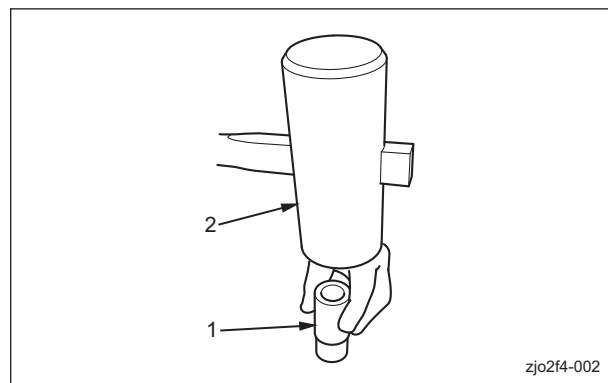

Oil Seal Installer_002

1	Oil Seal Installer
2	Hammer

Operating Machine and Mower Units

Adjustment

Adjustment of Blade Engagement

Check to see the clearance between the reel cutter (cutting cylinder) and the bed knife (bottom blade), and adjust them, if necessary. For the method of adjustment, refer to the Owner's Operating Manual.

Collimating

Caution

Both the reel cutter (cutting cylinder) and the bed knife (bottom blade) are edged tools. Handle them carefully, since they could cut your hands and feet.

1. Follow the steps below to install the bed knife mounting Assy to the mower unit.
 - [1] Make sure that no spring etc. is attached to the cutter adjustment bolt.
 - [2] Make sure that cam bushes are installed onto the left and right frames.
 - [3] Tighten the cutter pins to the maximum extent with fingers and install the bed knife mounting Assy.

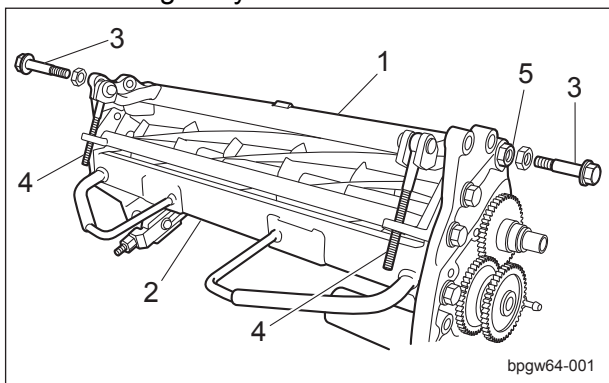

Collimating_001

1	Bed Knife Mounting Assy
2	Mower unit
3	Cutter pin
4	Cutter adjustment bolt
5	Cam bush

2. Position the punch marks of both left and right cam bushes to face toward the travelling direction.

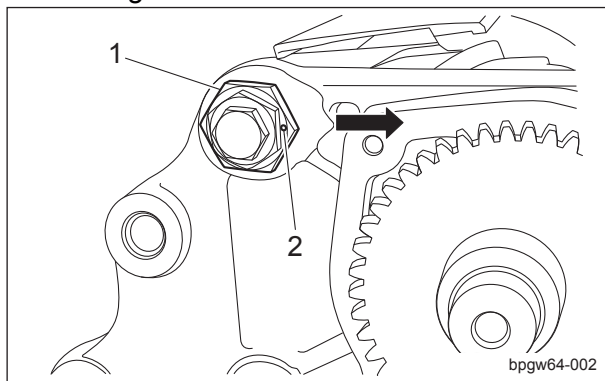

Collimating_002

1	Cam bush
2	Punch mark

3. Make sure that the reel cutter touches the bed knife.

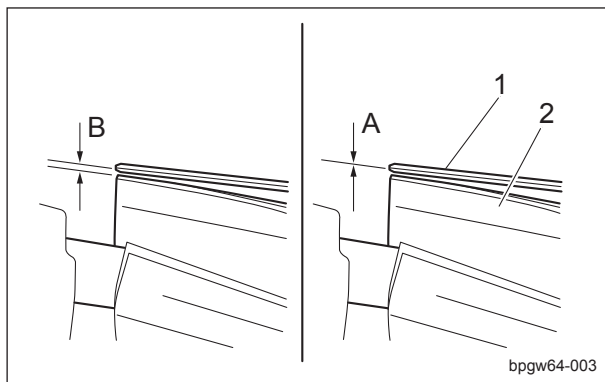

Collimating_003

1	Bed Knife
2	Reel cutter
A	No clearance
B	Some clearance

Operating Machine and Mower Units

Caution

Before cutting newspaper as a test, be sure to stop the engine and wear gloves to protect your hands. Pay attention not to let the reel cutter (cutting cylinder) catch your gloves during your rotating it. Otherwise, you may injure your hand or fingers.

Important

The reel cutter and bed knife are yet to be collimated so do not rotate the reel cutter swiftly.

4. Follow the steps below to check the sharpness for the entire reel cutter.
 - [1] Insert a strip of newspaper at a right angle to the bed knife and cut it by rotating the reel cutter slowly with hands.
 - [2] Check the sharpness at five or six parts from the left to the right of the reel cutter.

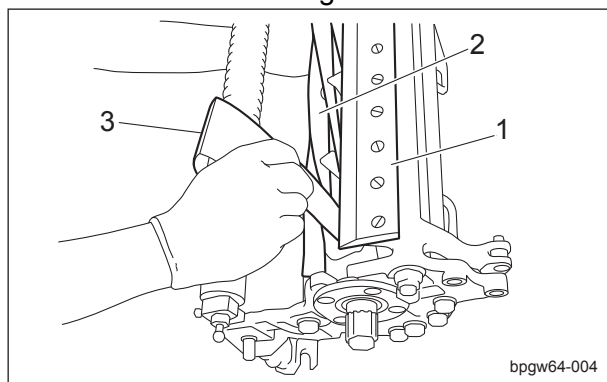

Collimating_004

1	Bed Knife
2	Reel
3	Newspaper

5. Adjust the position of the cam bushes so that newspaper is cut at both ends of the reel cutter.

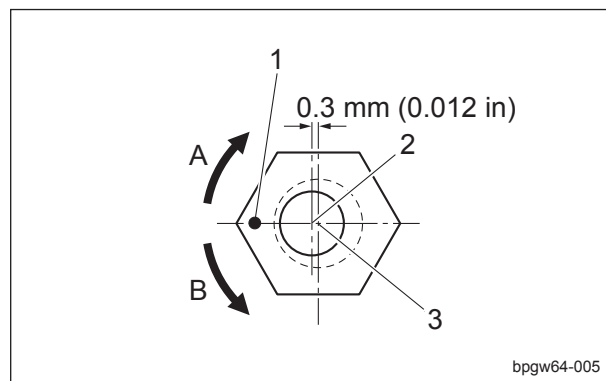

bpgw64-005

Collimating_005

1	Punch mark
2	Center of cutter pin
3	Center of cam bush
A	Bed knife (bottom blade) moving up
B	Bed knife (bottom blade) moving down

6. Mark the position of the punch mark on the mower unit with an indelible marker.

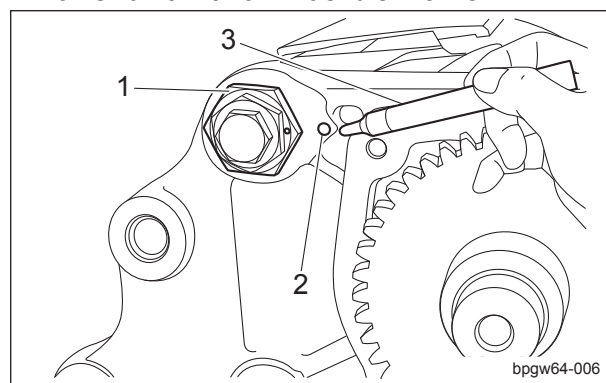

bpgw64-006

Collimating_006

1	Cam bush
2	Marking position
3	Indelible maker

Operating Machine and Mower Units

Important

Make sure that the cam bush does not move from the marking position when tightening the lock nut.

7. Tighten the lock nuts of the left and right cutter pins.

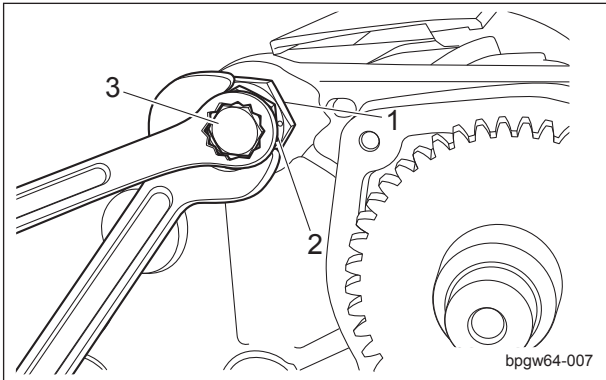

Collimating_007

1	Cam bush
2	Lock nut
3	Cutter pin

Adjustment of Cutter Adjustment Spring

Due to working conditions, the gap between the reel cutter (cutting cylinder) and the bed knife (bottom blade) may fluctuate. If necessary, check the clearance and make adjustment. Adjust the length of A to 26.0 mm (1.02 in) with the pipe with cutter adjustment screw.

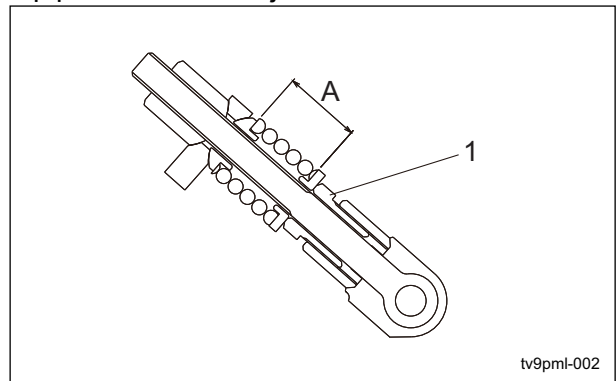

Adjustment of Cutter Adjustment Spring_001

1	Pipe with cutter adjustment screw
A	26.0 mm (1.02 in)

Cutting Height Adjustment

Adjust the front and rear rollers so as to obtain desired cutting height. See the owner's operating manual for method of adjustment.

Adjustment of Groomer Height

Note:
Depending on the specifications, this function may not be available. Adjust the groomer height at your will. For the method of adjustment, refer to the Owner's Operating Manual.

Removal and installation of each section

Mower unit

Removal of Mower Unit

1. Remove the clip which fixes the mower unit and flexible wire. Remove the flexible wire and hook it on the hook.

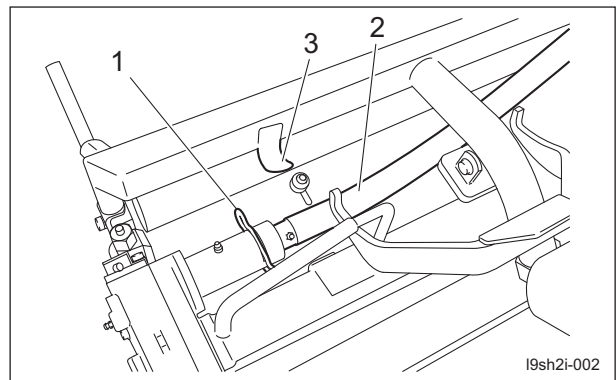

Removal of Mower Unit_001

1	Clip
2	Flexible wire
3	Hook

2. Slide the stopper of the mower mounting bracket forward and pull it up.

Operating Machine and Mower Units

3. Pull out the mower unit and remove it.

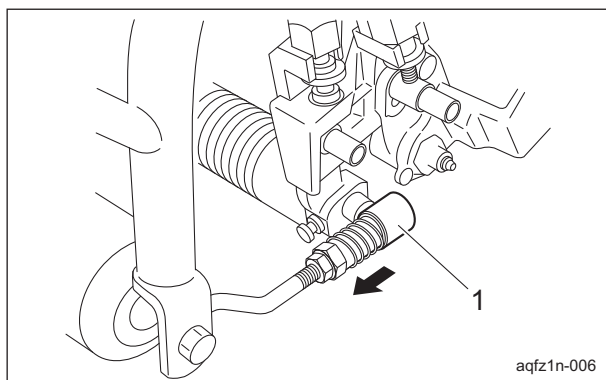

Removal of Mower Unit_002

1	Stopper (right/left)
---	----------------------

Installation of Mower Unit

⚠ Caution

See the list in "Tightening torques" (Page 3-6) .

Note that the Baroness product warranty may not apply to defects caused by incorrect or overtorque tightening etc.

For installation, reverse the removing procedure.

Groomer Assy

Removal of Groomer Assy

⚠ Caution

The reel cutter (cutting cylinder), bed knife (bottom blade), and groomer blades are all edged tools.

Handle them carefully, since they could cut your hands and feet.

1. Remove the mower unit. (See "Removal of Mower Unit" (Page 7-8) ".)
2. Turn the mower unit Assy with the front roller facing upward.
3. Follow the steps below to remove the bolts and nuts.

[1] Remove the gear case fixing bolt, spring washer, and washer holding the groomer Assy.

[2] Remove the high nut, spring washer and carriage bolt.

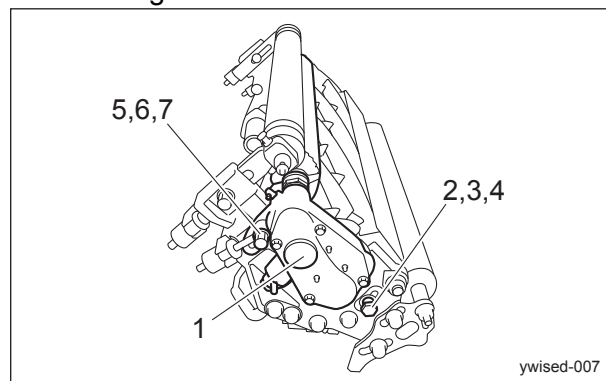

Removal of Groomer Assy_001

1	Groomer Assy
2	Gear case fixing bolt
3	Spring
4	Washer
5	High nut
6	Spring washer
7	Carriage bolt

4. Remove the high nut, spring washer A, spring washer and carriage bolt on the opposite side.
Remove the bolt and spring washer B and then remove the housing plate.

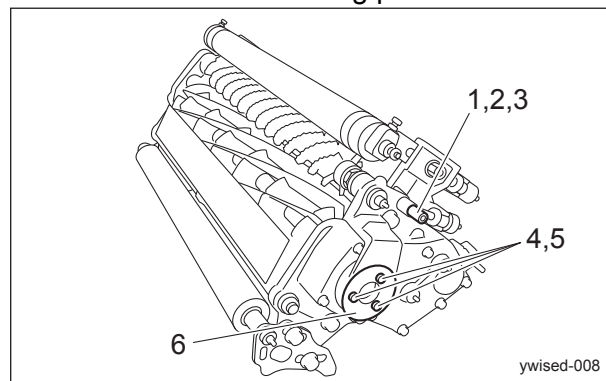

Removal of Groomer Assy_002

1	High nut
2	Spring washer A
3	Carriage bolt
4	Bolt
5	Spring washer B
6	Housing plate

Operating Machine and Mower Units

5. Hold the gear case in one hand and then slowly lift up the groomer in the direction of the arrow with the other hand.

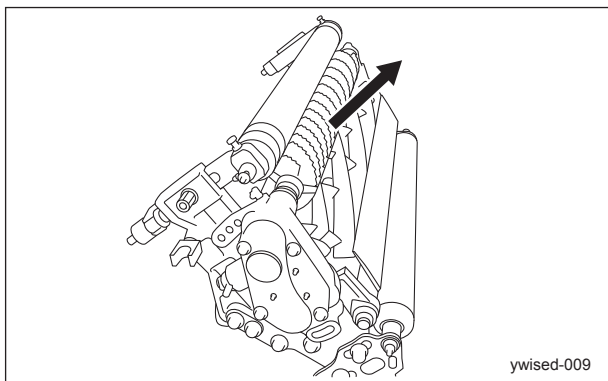

Removal of Groomer Assy_003

6. Hold and move the groomer in the direction of the arrow to remove the groomer.

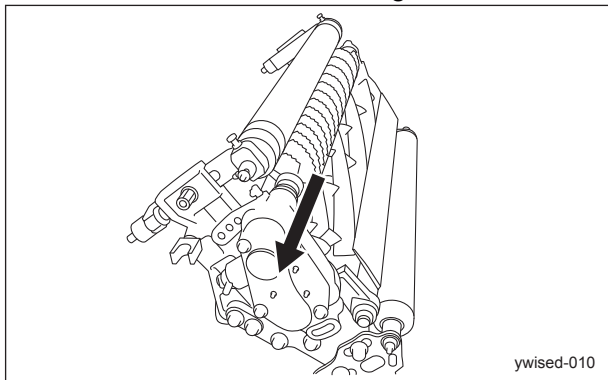

Removal of Groomer Assy_004

Installation of Groomer Assy

⚠ Caution

The reel cutter (cutting cylinder), bed knife (bottom blade), and groomer blades are all edged tools. Handle them carefully, since they could cut your hands and feet.

Important

Be sure to replace the O ring with a new one, if it is damaged.

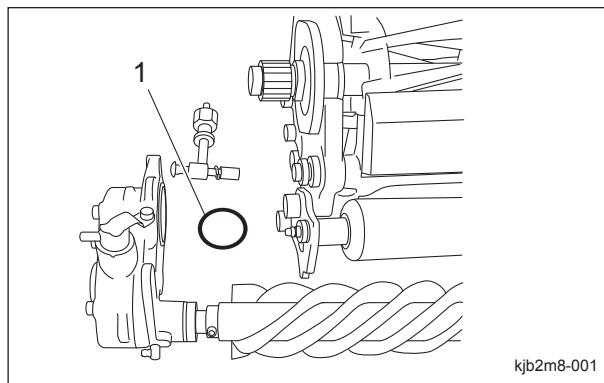

Installation of Groomer Assy_001

1	O-ring
---	--------

For installation, reverse the removing procedure.

Bed Knife Mounting Assy

Removal of Bed Knife Mounting Assy

⚠ Caution

The reel cutter (cutting cylinder), bed knife (bottom blade), and groomer blades are all edged tools. Handle them carefully, since they could cut your hands and feet.

1. Remove the mower unit and turn it upside down. (See " "Removal of Mower Unit" (Page 7-8) ".)

Operating Machine and Mower Units

- Loosen the lock nuts of the left and right cutter pins fixing the bed knife.

Note:

Loosen the cutter pins and, if it is tight, tighten or loosen the bed knife adjustment high nut to the extent that it does not touch the reel cutter to find the position where the cutter pin is loosen easily, and then loosen and remove the left and right cutter pins.

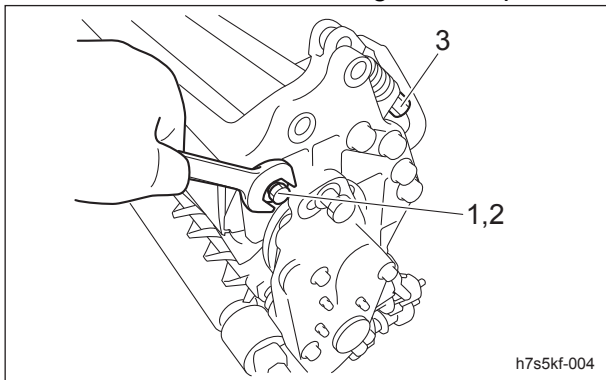

Removal of Bed Knife Mounting Assy_001

1	Lock nut
2	Cutter pin
3	Bed knife adjustment high nut

- Loosen the left and right bed knife adjustment high nut one after the other to remove them.

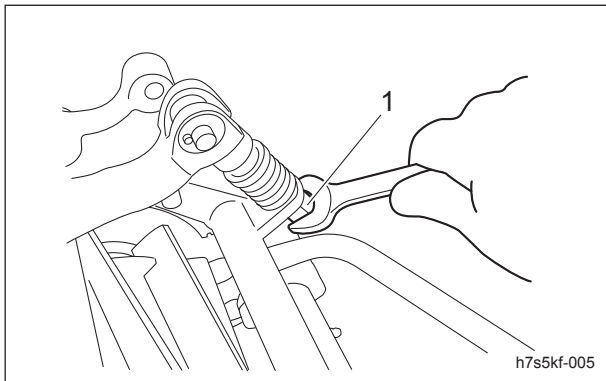

Removal of Bed Knife Mounting Assy_002

1	Bed knife adjustment high nut
---	-------------------------------

Important

The cutter adjustment part comes off when removing the bed knife mounting Assy. Be careful not to lose it.

- Lift up the bed knife mounting Assy, and then pull out it keeping its horizontal attitude to remove it from the mower unit.

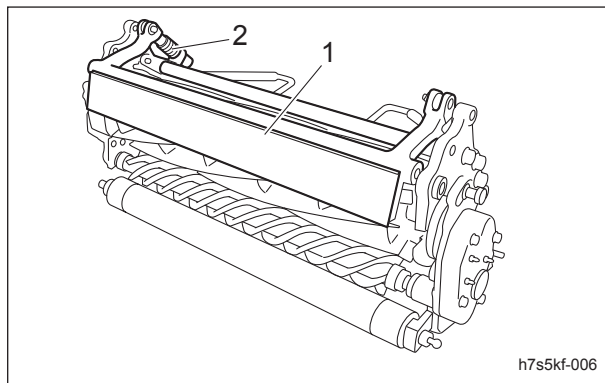

Removal of Bed Knife Mounting Assy_003

1	Bed Knife Mounting Assy
2	Cutter adjustment part

Operating Machine and Mower Units

Installation of Bed Knife Mounting Assy

Caution

The reel cutter (cutting cylinder), bed knife (bottom blade), and groomer blades are all edged tools. Handle them carefully, since they could cut your hands and feet.

1. Collimate them. (See "Collimating" (Page 7-6).)

Important

The cutter adjustment part has two types of spring holders. Be careful not to install it in a wrong position.

2. Follow the steps below to install the bed knife mounting Assy.
 - [1] Make sure that the bed knife adjustment high nut is removed.
 - [2] Insert the left and right cutter adjustment parts into the cutter adjustment holders.
 - [3] Insert the bed knife mounting Assy keeping its horizontal attitude into the mower unit.
 - [4] Install the bed knife adjustment high nut.

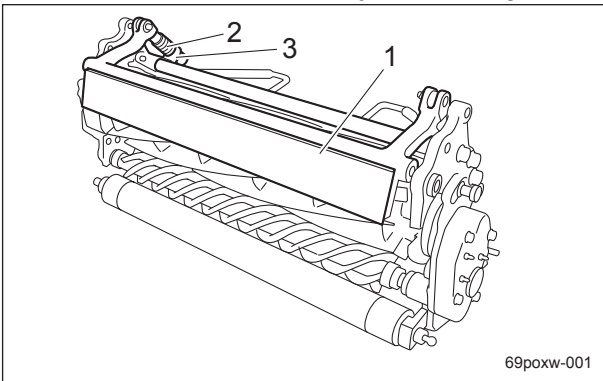

Installation of Bed Knife Mounting Assy_001

1	Bed Knife Mounting Assy
2	Cutter adjustment part
3	Cutter adjustment part holder

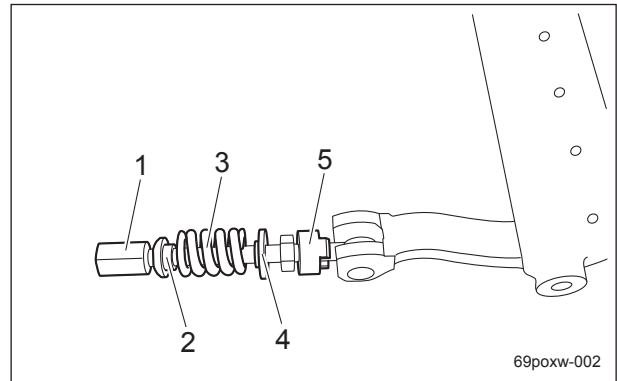

Installation of Bed Knife Mounting Assy_002

1	Bed knife adjustment high nut
2	Spring holder A
3	Spring
4	Spring holder B
5	Spring adjustment Assy

3. Tighten the bed knife adjustment high nut. At the same time, press the bed knife mounting Assy in the direction of the arrow and adjust its position so that the installation hole of the bed knife mounting Assy fits into the center of the cam bush.

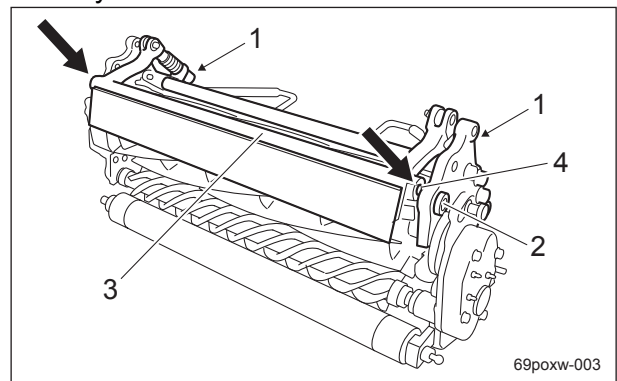

Installation of Bed Knife Mounting Assy_003

1	Bed knife adjustment high nut
2	Cam bush
3	Bed Knife Mounting Assy
4	Installation hole of the bed knife mounting Assy

4. Follow the steps below to install the cutter pin.
 - [1] Temporarily install the lock nut onto the cutter pin.

Operating Machine and Mower Units

[2] Position the punch mark of the cam bush on the position of the marking made at the time of collimating, and then tighten the lock nut.

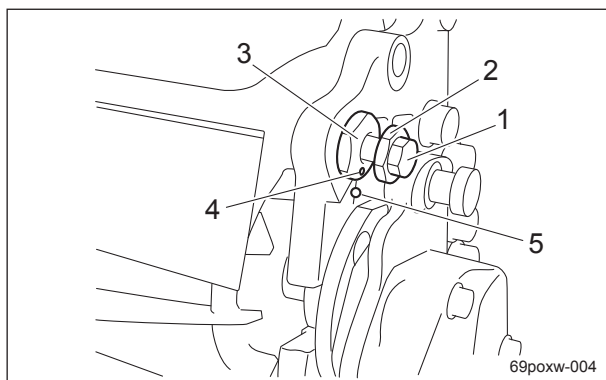

Installation of Bed Knife Mounting Assy_004

1	Cutter pin
2	Lock nut
3	Cam bush
4	Punch mark
5	Marking position

5. Adjust blade engagement. (See the Owner's Operating Manual)
6. Tighten the pipe with cutter adjustment screw until it stops in the direction of arrow A. Turn back one revolution.

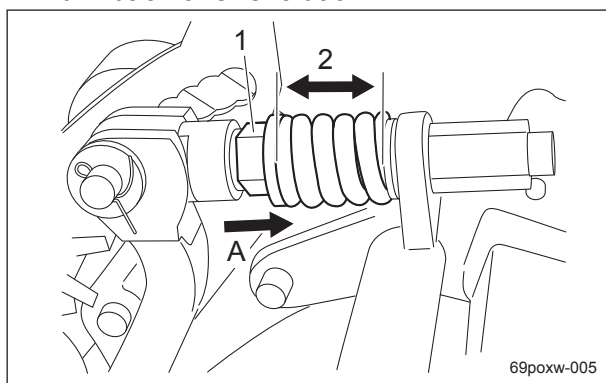

Installation of Bed Knife Mounting Assy_005

1	Pipe with cutter adjustment screw
2	Spring adjustment distance

7. Adjust cutting height. (See the Owner's Operating Manual)
8. Install the mower unit. (See "Installation of Mower Unit" (Page 7-9) .)

Reel Cutter

Removal of Reel Cutter

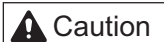

Caution
The reel cutter (cutting cylinder), bed knife (bottom blade), and groomer blades are all edged tools. Handle them carefully, since they could cut your hands and feet.

1. Remove the mower unit and turn it upside down. (See " "Removal of Mower Unit" (Page 7-8) ".)
2. Remove the groomer Assy. (See " "Groomer Assy" (Page 7-9) ".)
3. Remove the bed knife mounting Assy. (See " "Removal of Bed Knife Mounting Assy" (Page 7-10) ".)
4. Follow the steps below to remove the reel reverse lever.

- [1] Remove the bolt, spring washer and washer, and then remove the clutch lever clamber.
- [2] Remove the reel reverse lever.

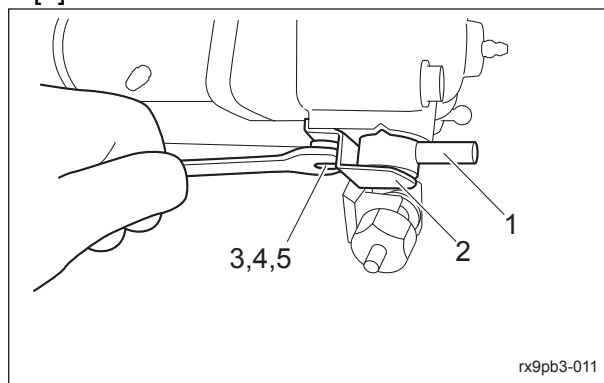

Removal of Reel Cutter_001

1	Reel reverse lever
2	Clutch lever clamber
3	Bolt
4	Spring washer
5	Washer

Operating Machine and Mower Units

5. Remove the bolt and then the gear cover and gear cover packing.

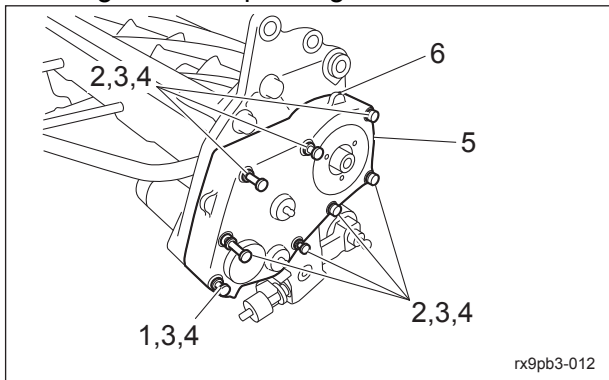

Removal of Reel Cutter_002

1	Bolt A
2	Bolt B
3	Spring washer
4	Washer
5	Gear Cover
6	Gear cover packing

6. Follow the steps below to remove reel gear A.

[1] Remove the reel gear nut holding reel gear A with a wrench.

[2] Remove reel gear A.

[3] Remove the wave washer.

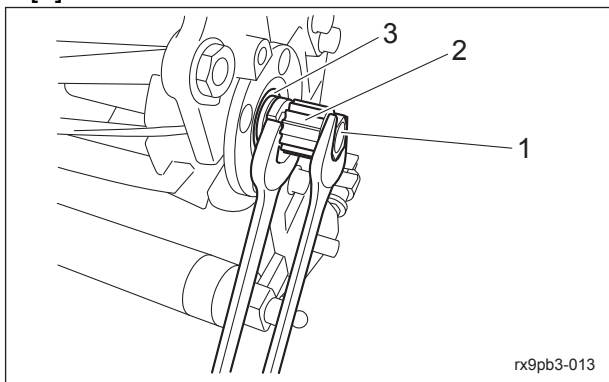

Removal of Reel Cutter_003

1	Reel gear nut
2	Reel gear A
3	Wave washer

Important

When removing the reel gear, the reel cutter rotates.
To fix it, insert a piece of wood during work.

7. Remove reel gear A and wave washer.

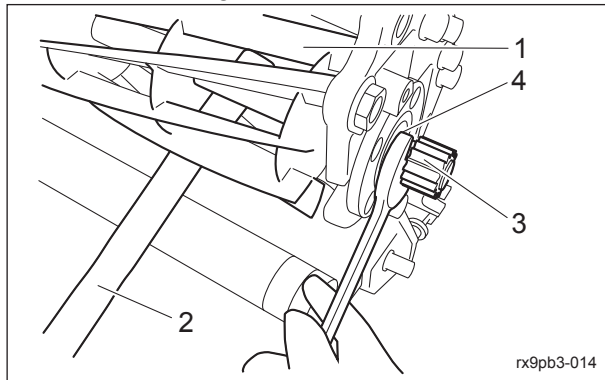

Removal of Reel Cutter_004

1	Reel cutter
2	Piece of wood
3	Reel gear A
4	Wave washer

8. Follow the steps below to remove reel gear B.

[1] Remove the O ring.

[2] Remove the cover for pin lock.

[3] Pull out the pin with the pin puller.

[4] Pull out reel gear B in the direction of the arrow.

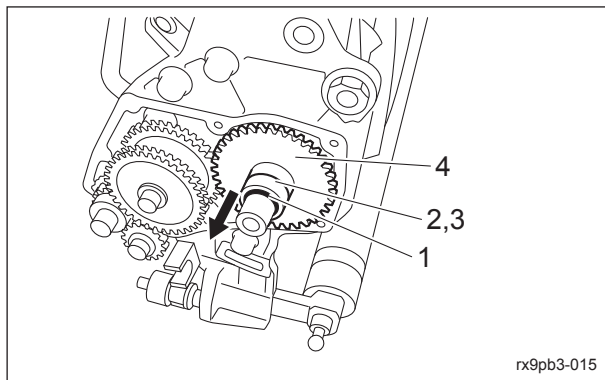

Removal of Reel Cutter_005

1	O-ring
2	Cover for pin lock
3	Pin
4	Reel gear B

Operating Machine and Mower Units

9. Remove the key from the reel cutter shaft.

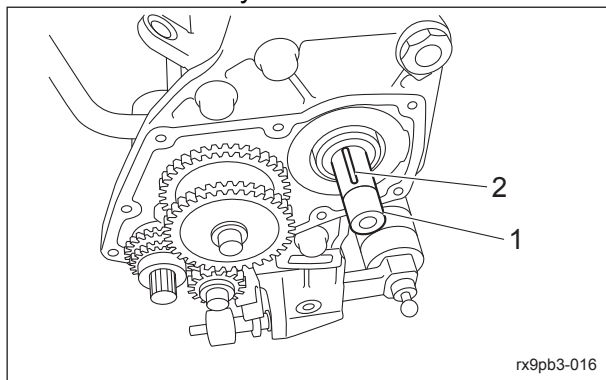

Removal of Reel Cutter_006

1	Reel cutter shaft
2	Key

Important

Be sure to hold the reel cutter when removing the reel housing Assy.
If the reel cutter shaft is damaged, the reel cutter is hard to remove, so fix the damage before removing it.

10. Remove the bolt.

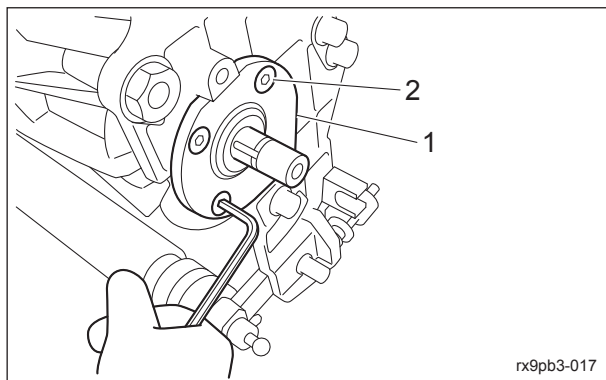

Removal of Reel Cutter_007

1	Reel housing Assy
2	Bolt

11. Pull out reel housing Assy in the direction of the arrow.

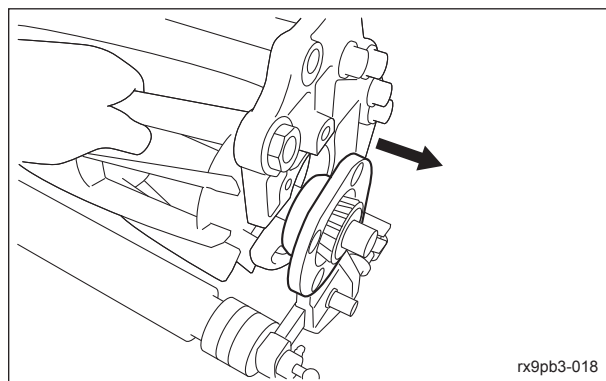

Removal of Reel Cutter_008

Important

If the reel cutter shaft is damaged, the reel cutter is hard to remove, so fix the damage before removing it.

12. Follow the steps below to remove the reel cutter.

[1] Remove the taper roller bearing (inner) of the left frame side.

[2] Remove the reel cutter from the frame.

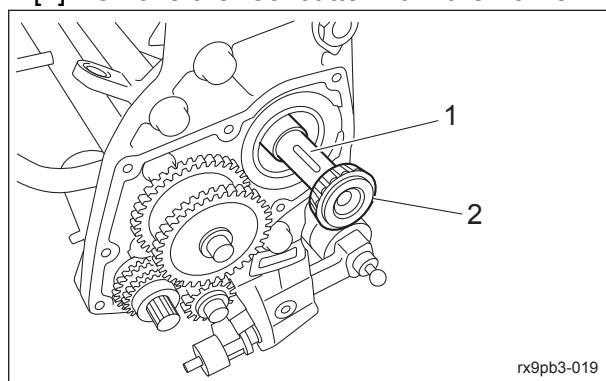

Removal of Reel Cutter_009

1	Cutter
2	Taper roller bearing (inner)

Operating Machine and Mower Units

Attaching Reel Cutter (Cutting Cylinder)

Caution

The reel cutter (cutting cylinder), bed knife (bottom blade), and groomer blades are all edged tools. Handle them carefully, since they could cut your hands and feet.

Important

Be sure to replace the oil seals and bearings with new ones.

1. Apply a profuse amount of grease to new bearings and oil seals. To bearings, apply grease like rubbing until the grease leaks from the other side. Also apply a profuse amount of grease to the lip of the oil seal.

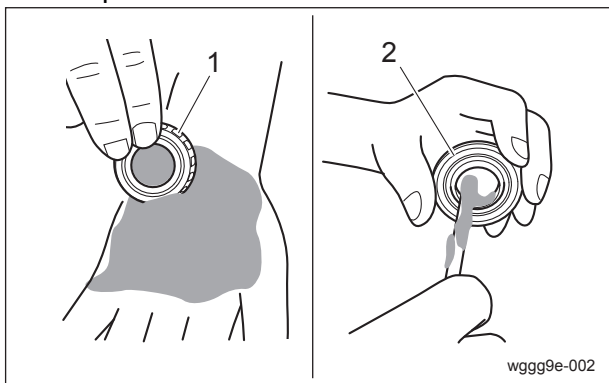

Attaching Reel Cutter (Cutting Cylinder)_001

1	Taper roller bearing
2	Oil seal

2. For installation, reverse the removing procedure.
3. Follow the steps below to tighten the reel cutter nut.
 - [1] Insert two wave washers.
 - [2] Tighten the reel gear nut and check the taper roller bearing for backlash.
 - [3] Loosen the reel gear nut at the level that the reel cutter (cutting cylinder) can be rotated lightly by your hand and you don't feel the backlash. Tightening torque: 7.0 N-m (71.4 kgf-cm / 61.96 lb-in)

- [4] Tighten the reel gear nut holding reel gear A with a wrench.

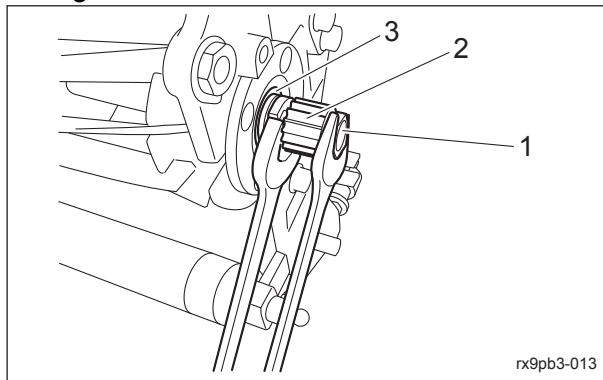

Attaching Reel Cutter (Cutting Cylinder)_002

1	Reel gear nut
2	Reel gear A
3	Wave washer

Front Roller Assy

Removal of Front Roller Assy

Caution

The reel cutter (cutting cylinder), bed knife (bottom blade), and groomer blades are all edged tools. Handle them carefully, since they could cut your hands and feet.

1. Remove the high nut, spring washer, and washer fastening the front roller bracket on the left frame side.

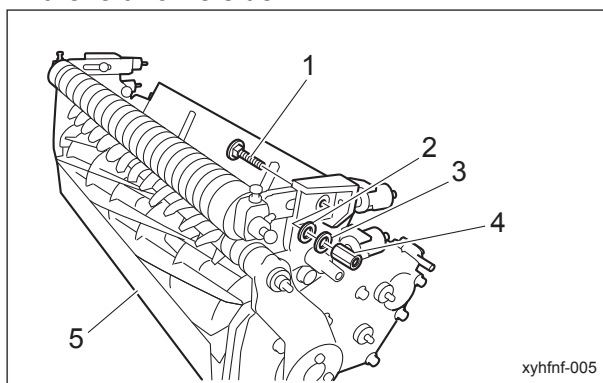

Removal of Front Roller Assembly_001

1	Round-head square-root bolt
2	Washer
3	Spring washer
4	High nut
5	Mower unit Assy

Operating Machine and Mower Units

2. Loosen the lock nut of the bolt fixing the front roller on the right side of the mower unit and then loosen the bolt by one turn.

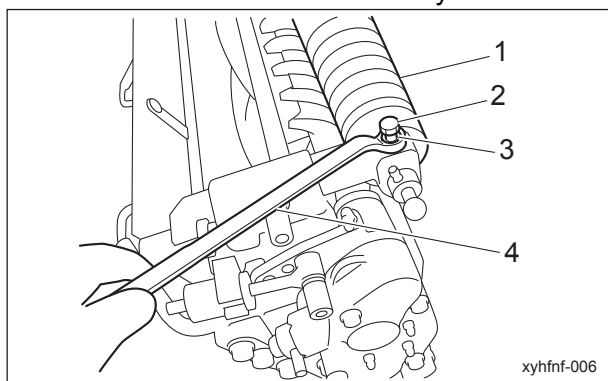

Removal of Front Roller Assembly_002

1	Front Roller
2	Bolt
3	Lock nut
4	Ring wrench

3. Remove mower mounting bolt B and washer while holding the front roller. Mower mounting bolt B is the right screw.

Note:

If the roller is hard to remove, loosen the round-head square-root bolt of roller bracket B before removing the roller a little to make a play in the bracket, which makes removal smoother.

However, in this case, the front roller may drop just after the round-head square-root bolt is removed so hold it securely with your hands.

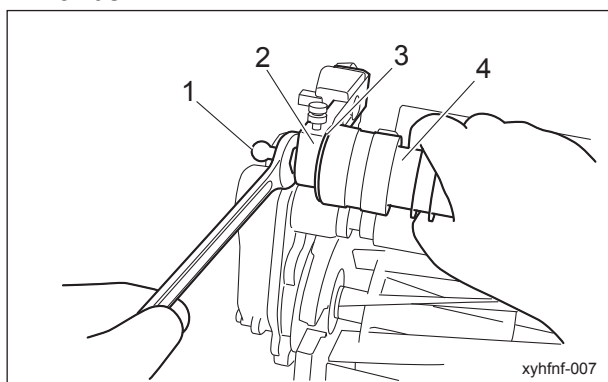

Removal of Front Roller Assembly_003

1	Mower mounting bolt B
2	Roller bracket B
3	Washer
4	Front Roller

4. Remove the front roller Assy with holding it with both hands.

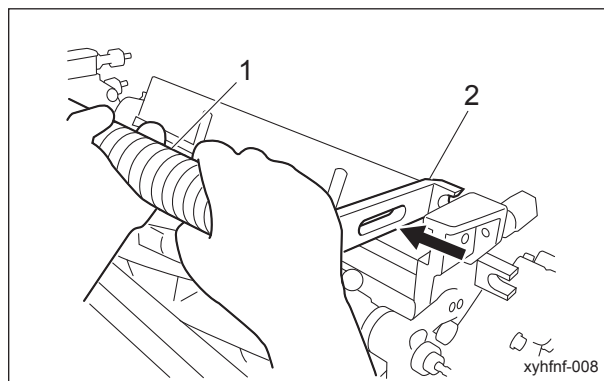

Removal of Front Roller Assembly_004

1	Front roller Assy
2	Roller bracket A

5. Remove mower mounting bolt A with holding the front roller. Mower mounting bolt A is the left screw.

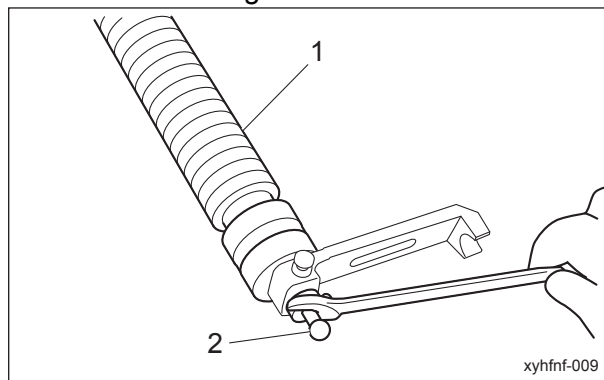

Removal of Front Roller Assembly_005

1	Front Roller
2	Mower mounting bolt A

Operating Machine and Mower Units

Important

The part of the front roller shaft fixing bolt fixed to the front roller shaft is processed to be flat.

Confirm it before loosening the bolt.

6. Loosen the lock nut and bolt of roller bracket A and then remove roller bracket A.

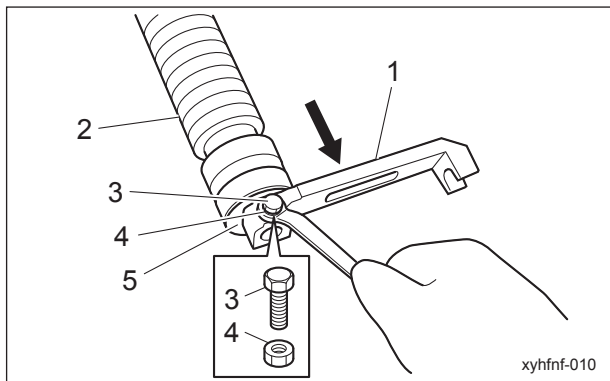

Removal of Front Roller Assembly_006

1	Roller bracket A
2	Front Roller
3	Bolt
4	Lock nut
5	Washer

Installation of Front Roller Assy

Caution

The reel cutter (cutting cylinder), bed knife (bottom blade), and groomer blades are all edged tools.

Handle them carefully, since they could cut your hands and feet.

For installation, reverse the removing procedure.

Note:

Follow the steps below to adjust the grease nipple position of the mower mounting bolt.

[1] Fully tighten mower mounting bolt A. (The white arrow indicates the travelling direction)

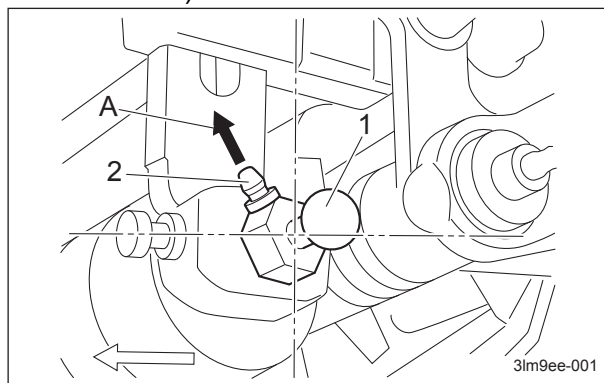

Installation of Front Roller Assy_001

1	Mower mounting bolt A
2	Grease nipple
A	Direction of 45 degrees

[2] If the grease nipple position of mower mounting bolt A is not positioned 45 degrees upward toward the travelling direction, insert the necessary number of adjustment washers into mower mounting bolt A to adjust the angle.

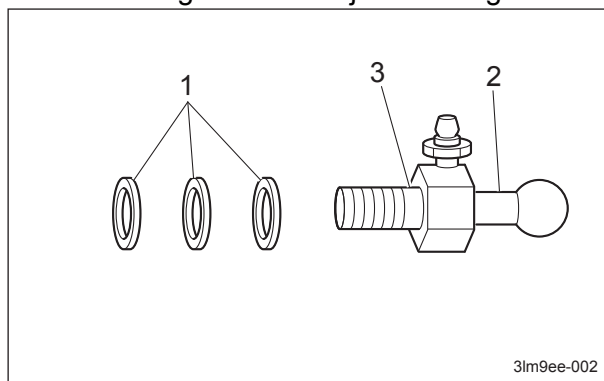

Installation of Front Roller Assy_002

Operating Machine and Mower Units

1	Adjustment washer
2	Mower mounting bolt A
3	Part to insert the adjustment washer

[3] Follow the same steps to adjust the mower mounting bolt on the opposite side as well.

Rear Roller Assy

Removal of Rear Roller Assy

⚠ Caution

The reel cutter (cutting cylinder), bed knife (bottom blade), and groomer blades are all edged tools.

Handle them carefully, since they could cut your hands and feet.

1. Remove the mower unit from this machine. (See "Removal of Mower Unit" (Page 7-8).)
2. Turn up the mower units.

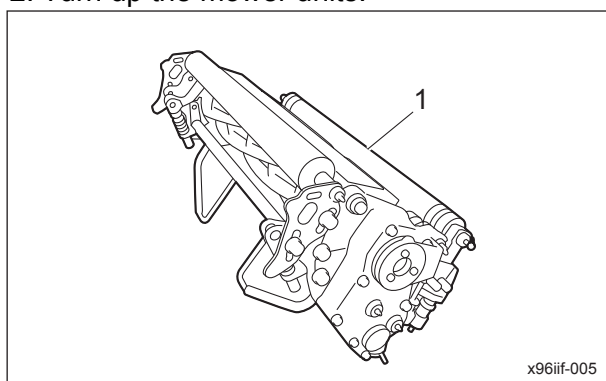

Removal of Rear Roller Assy_001

1	Mower unit
---	------------

3. Remove the special bolts, spring washers, and washers fixing the left and right rear roller brackets, and then the rear roller Assy with the brackets installed.

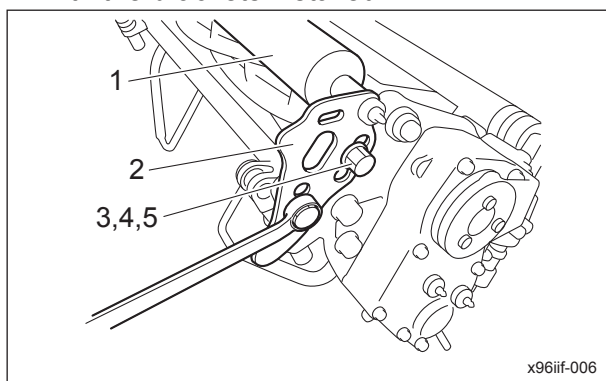

Removal of Rear Roller Assy_002

1	Rear roller
2	Rear roller bracket
3	Washer
4	Spring washer
5	Special bolt

4.

- [1] Remove the spring washers and nuts from the rear roller, and then remove the left and right rear roller brackets.

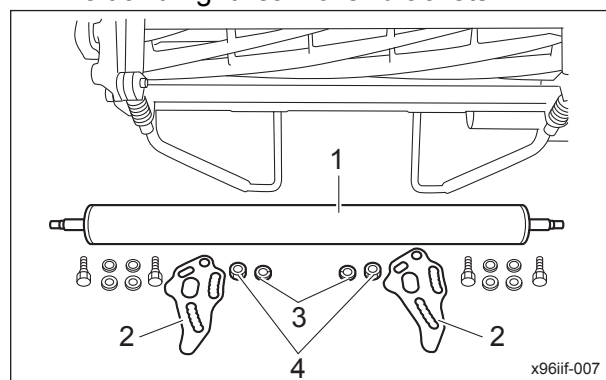

Removal of Rear Roller Assy_003

1	Rear roller
2	Rear roller bracket
3	Spring washer
4	Nut

Installation of Rear Roller Assy

For installation, reverse the removing procedure.

Operating Machine and Mower Units

Grass catcher roller

Removal of Grass Catcher Roller Assy

⚠ Caution

The reel cutter (cutting cylinder), bed knife (bottom blade), and groomer blades are all edged tools. Handle them carefully, since they could cut your hands and feet.

1. Slide the stopper of the mower mounting bracket forward, and then remove the mower mounting bracket from the ball joint.

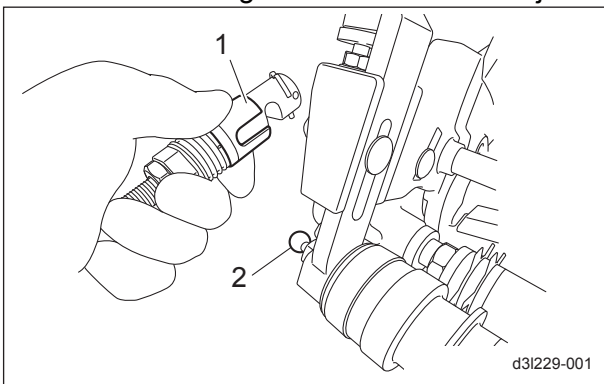

Installation of Grass Catcher Roller Assy_001

1	Stopper
2	Ball joint

2. Remove the bolts and spring washers fixing the grass catcher roller Assy.

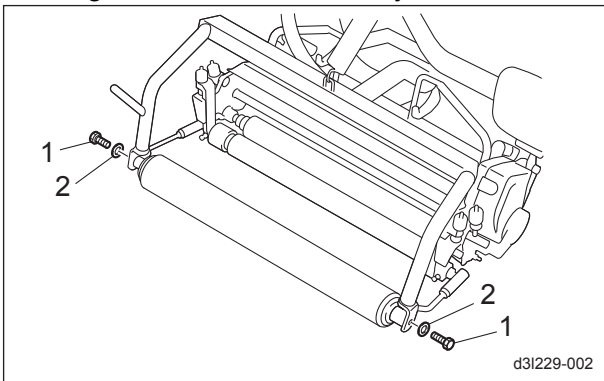

Installation of Grass Catcher Roller Assy_002

1	Bolt
2	Spring washer

3. Remove the mower mounting brackets, washers, and grass catcher roller Assy.

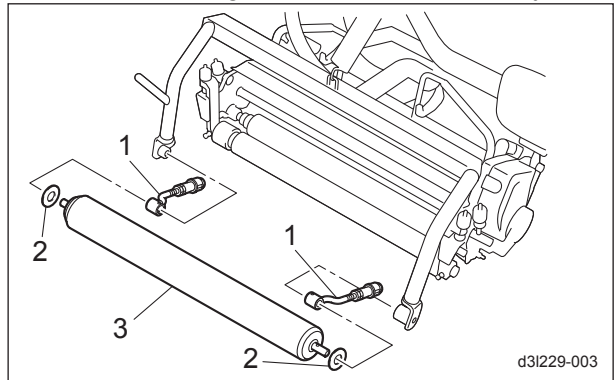

Installation of Grass Catcher Roller Assy_003

1	Mower mounting bracket
2	Washer
3	Grass catcher roller Assy

Installation of Grass Catcher Roller Assy

⚠ Caution

The reel cutter (cutting cylinder), bed knife (bottom blade), and groomer blades are all edged tools. Handle them carefully, since they could cut your hands and feet.

For installation, reverse the removing procedure.

Note:

Follow the steps below to install the mower mounting bracket.

- [1] Install the mower mounting bracket with the larger notch of the ball joint holder facing downward.

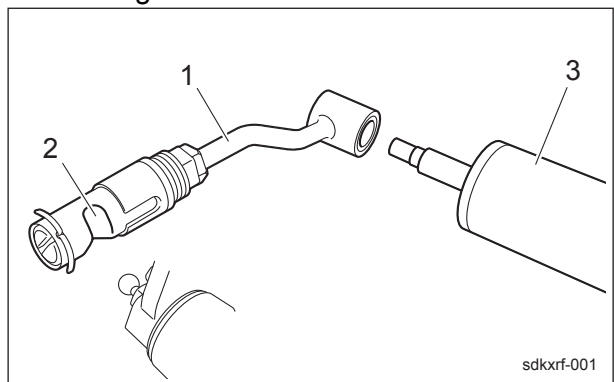

Installation of Grass Catcher Roller Assy_001

1	Mower mounting bracket
2	Ball joint holder
3	Grass catcher roller Assy

Operating Machine and Mower Units

- [2] Follow the same steps to install the mower mounting bracket on the opposite side as well.

CR Brush Driver

Removal of CR Brush Driver Assy

Caution

The reel cutter (cutting cylinder), bed knife (bottom blade), and groomer blades are all edged tools. Handle them carefully, since they could cut your hands and feet.

1. Remove the mower unit and turn it upside down. (See "Removal of Mower Unit" (Page 7-8) ".)
2.
 - [1] Remove the bracket mounting bolt, spring washer, and washer A.
 - [2] Remove washer B, spring washer, and nut fixing the rear roller.
 - [3] Pull out the rear roller bracket in the direction of the arrow.

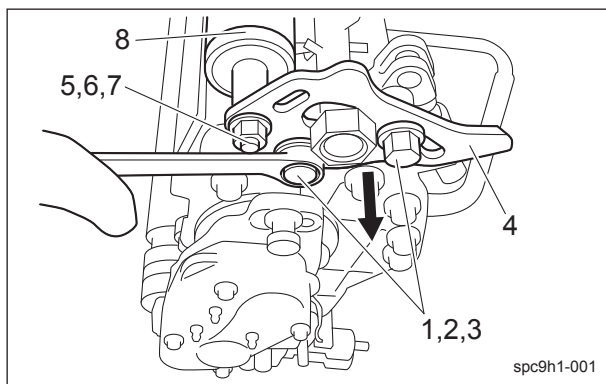

Removal of CR Brush Driver Assy_001

1	Bracket mounting bolt
2	Spring washer
3	Washer A
4	Rear roller bracket
5	Washer B
6	Spring washer
7	Nut
8	Rear roller

3. Remove the special bolt and U nut fixing the brush and pull out the brush in the direction of the arrow.

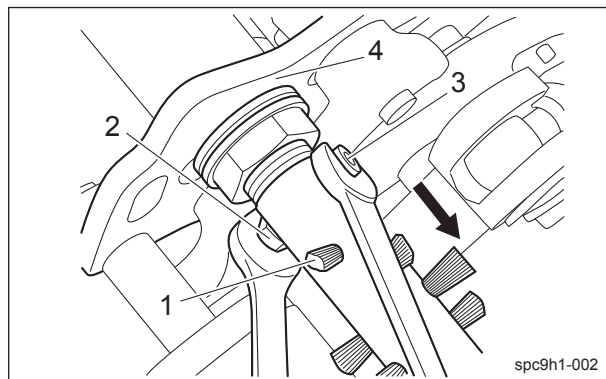

Removal of CR Brush Driver Assy_002

1	Brush
2	Special bolt
3	U nut
4	Brush Driver

4. If the movement of the bearing of the brush fulcrum metal Assy is bad, follow the steps below to replace the bearing.
 - [1] Remove the brush fulcrum metal Assy from the rear roller bracket.

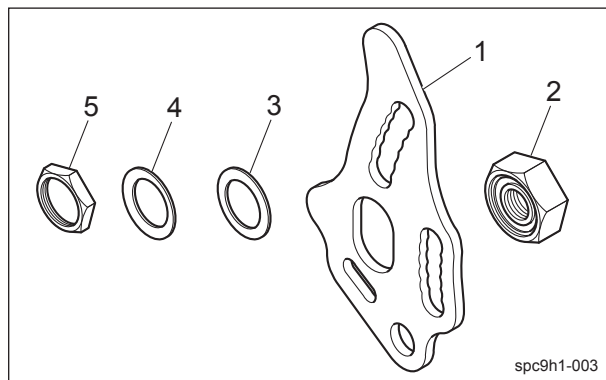

Removal of CR Brush Driver Assy_003

1	Rear roller bracket
2	Brush fulcrum metal Assy
3	Washer
4	Spring washer
5	Nut

Operating Machine and Mower Units

[2] For the brush fulcrum metal Assy, remove the stop ring and then replace the bearing.

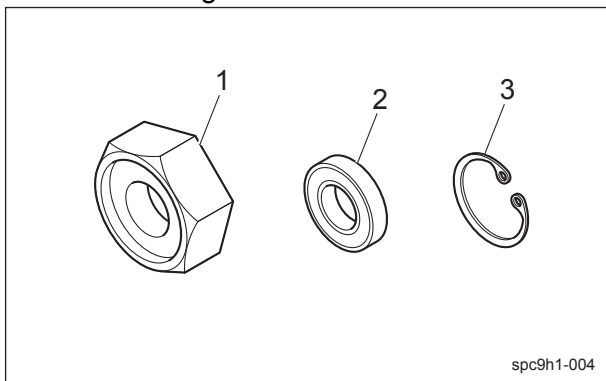

Removal of CR Brush Driver Assy_004

1	Brush fulcrum metal
2	Bearing
3	Stop ring

Installation of CR Brush Driver Assy

⚠ Danger

The reel cutter (cutting cylinder), bed knife (bottom blade), and groomer blades are all edged tools. Handle them carefully, since they could cut your hands and feet.

⚠ Caution

See the list in "Tightening torques" (Page 3-6)". Note that the Baroness product warranty may not apply to defects caused by incorrect tightening etc.

1. For installation, reverse the removing procedure.

Inspection and repair of each section

Reel cutter

Important

Be sure to replace the oil seals and bearings with new ones.

The reel cutter (cutting cylinder) may become dull due to frequent use, objects crushed during mowing, or damage caused during transportation.

Inspect it, and if necessary, grind or replace the reel cutter.

- Make sure that the welding between the reel cutter (cutting cylinder) and the disc has not come off.
- Make sure that the reel cutter is not cracked.
- Check to see whether or not the "relief" surface remains at the point of reel cutter (cutting cylinder).
- Make sure that the reel cutter is not tempered.
- Check to see how much the reel cutter is worn.

Refer to "Removal of Reel Cutter" (Page 7-13) and "Attaching Reel Cutter (Cutting Cylinder)" (Page 7-16) for information on attaching and removing the reel cutter.

Back Lapping

Back lapping is work similar to sharpening a cooking knife. If the edges of the reel cutter (cutting cylinder) and the bed knife (bottom blade) become blunt and make cutting difficult, both the reel cutter (cutting cylinder) and the bed knife (bottom blade) should be simultaneously sharpened by reversing the reel cutter (cutting cylinder) with an abrasive paste applied.

However, back lapping is a temporary measure and would not restore the sharpness completely.

If the edges of the reel cutter (cutting cylinder) and the bed knife (bottom blade) become blunt and make cutting difficult, perform back lapping.

For the back lapping procedure, refer to the Owner's Operating Manual.

Grind

⚠ Caution

The reel cutter and the bed knife are sharp blades. Exercise adequate care in handling to avoid cutting hands and/or feet.

The purposes of the grind of reel cutter are to implement cylindrical grinding and to make the "relief" surface.

Operating Machine and Mower Units

Implement the grind of reel cutter if the sharpness cannot be improved even after backlapping or if the "relief" surface is eliminated and so it takes longer time for backlapping since the contact area of the reel cutter and the bedknife increases.

Reel Housing

Important

The outer and inner taper roller bearings must be replaced together.

Wear of bearings due to frequent use and/or damage of bearing etc. caused by invasion of water may prevent smooth rotation of the reel cutter.

Inspect and replace the parts such as the oil seal or bearings.

- Make sure that the reel housing and frame does not have any crack.
- Make sure that the axis bolt and housing bolt receptacles do not bite the ground.
- Make sure that the bearing receptacles do not bite the ground.

! Danger

The reel cutter (cutting cylinder), bed knife (bottom blade), and groomer blades are all edged tools.

Handle them carefully, since they could cut your hands and feet.

1. Remove the oil seal with a flat-blade screwdriver.

Note:

It is not press-fitted so you can remove it smoothly by pulling it out evenly.

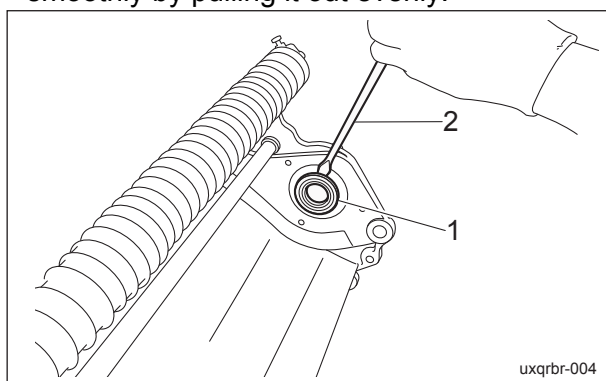

Reel Housing_001

1	Oil seal
2	Flat-blade screwdriver

2. Remove the taper roller bearing (outer) by knocking it evenly on its circle with a flat-blade screwdriver.

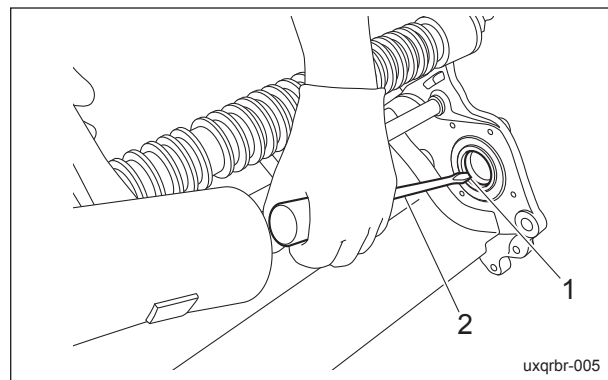

Reel Housing_002

1	Taper roller bearing (outer)
2	Flat-blade screwdriver

3. Fix the reel housing with a vise etc. and then remove the oil seal with a flat-blade screwdriver.

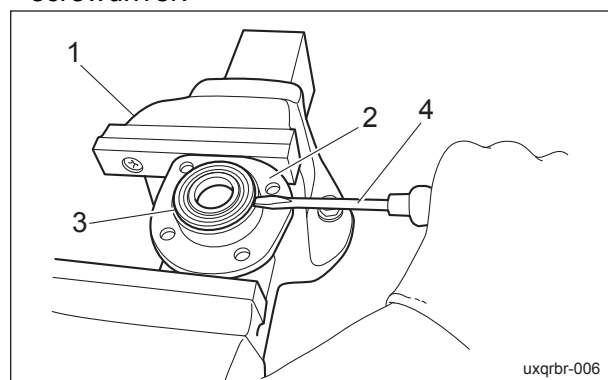

Reel Housing_003

1	Vise
2	Reel Housing
3	Oil seal
4	Flat-blade screwdriver

Operating Machine and Mower Units

4. Remove the taper roller bearing (outer) by knocking it evenly on its circle with a flat-blade screwdriver.

Note:

It is not press-fitted so you can remove it smoothly by pulling it out evenly.

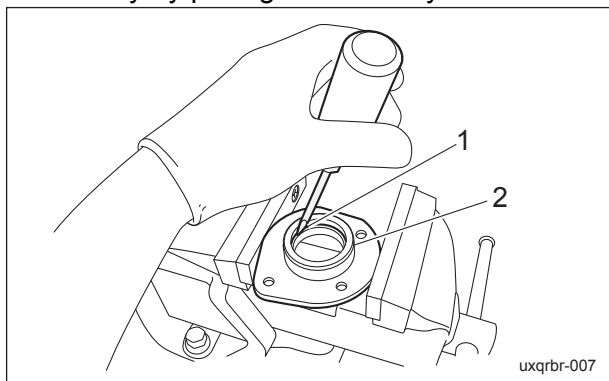

Reel Housing_004

1	Taper roller bearing (outer)
2	Reel Housing

Important

Be sure to replace the oil seals and bearings with new ones.

5. Apply a profuse amount of grease to new bearings and oil seals.
To bearings, apply grease like rubbing until the grease leaks from the other side.
Also apply a profuse amount of grease to the lip of the oil seal.

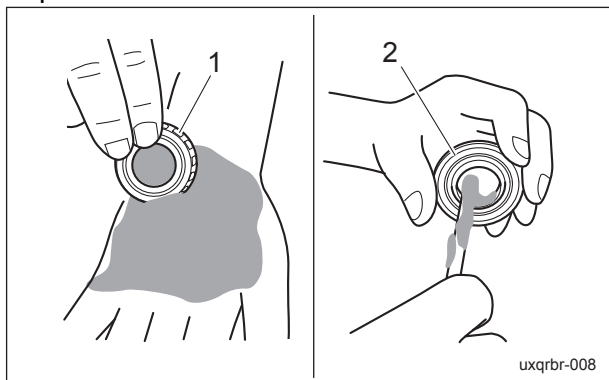

Reel Housing_005

1	Taper roller bearing
2	Oil seal

6. Tap the taper roller bearing (outer) into the reel housing evenly.

Note:

Use a bearing driver to drive in the bearings and oil seals.

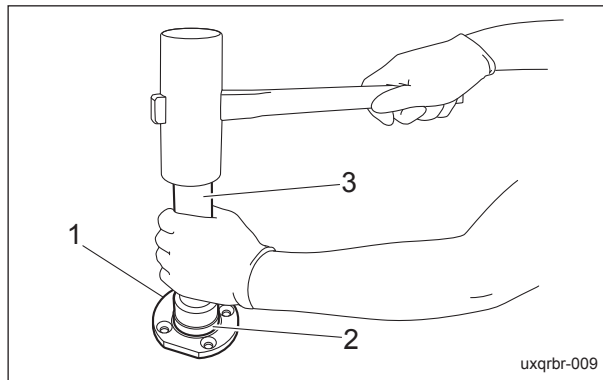

Reel Housing_006

1	Reel Housing
2	Taper roller bearing (outer)
3	Installer

7. Tap the oil seal into the frame housing evenly.

Note:

Use a bearing driver to drive in the bearings and oil seals.

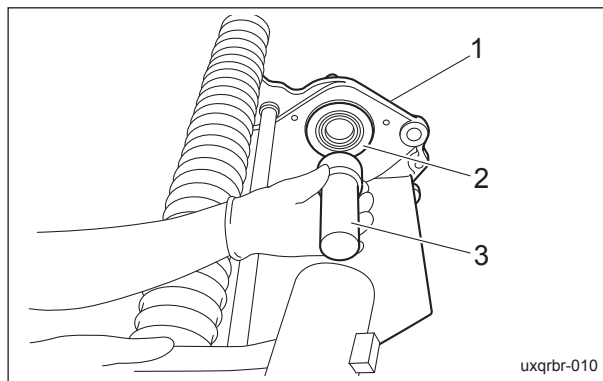

Reel Housing_007

1	Frame
2	Oil seal
3	Installer

Operating Machine and Mower Units

- Tap the taper roller bearing (outer) into the frame evenly.

Note:

Use a bearing driver to drive in the bearings and oil seals.

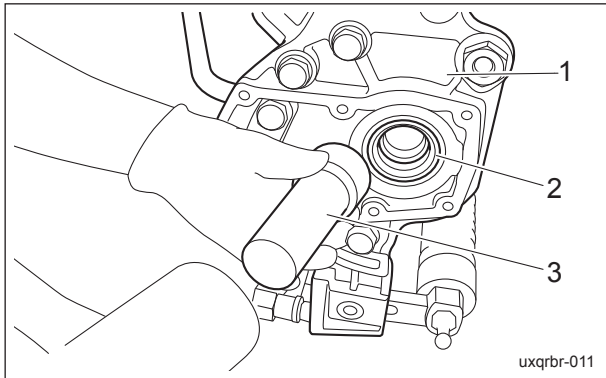

Reel Housing_008

1	Frame
2	Taper roller bearing (outer)
3	Installer

- Make sure that the oil seal and taper roller bearing (outer) are drove in correctly.

One-shaft Housing

Wear of the bearing or needle bearing due to frequent use and/or damage of bearing etc. caused by invasion of water may prevent smooth rotation of the mower shaft. Inspect and replace the parts such as the oil seal, bearing, needle bearing, etc.

- Make sure that there is no abrasion or rust of the bearing nor needle bearing, and that the one-shaft housing and needle bearing have no play.
- Make sure that the one-shaft housing and oil seal have no play.
- Make sure that the one-shaft housing does not have any crack.

! Danger

The reel cutter (cutting cylinder), bed knife (bottom blade), and groomer blades are all edged tools. Handle them carefully, since they could cut your hands and feet.

! Caution

See the list in " "Tightening torques" (Page 3-6) ". Note that the Baroness product warranty may not apply to defects caused by incorrect tightening etc.

- Remove the gear cover and then the transmission gear. (See " "Transmission Gear" (Page 7-29) ".)

2.

- [1] Remove the flathead screw and bearing retaining washer.

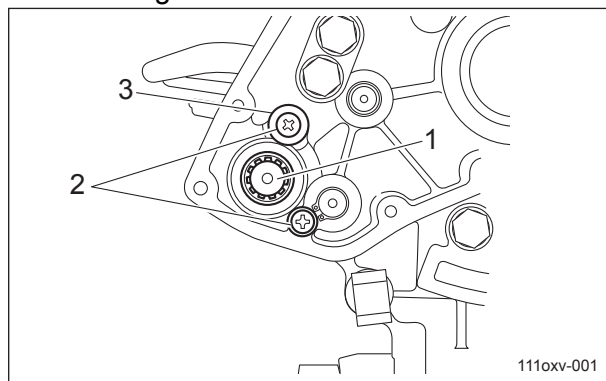

One-shaft Housing_001

1	One-shaft housing Assy
2	Flathead screw
3	Bearing retaining washer

Operating Machine and Mower Units

3. Remove the one-shaft housing Assy and one-shaft housing packing from the mower unit.

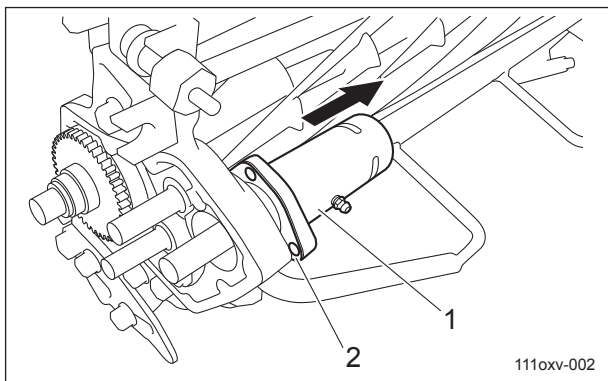

One-shaft Housing_002

1	One-shaft housing Assy
2	One-shaft housing packing

Important

The stop ring has a specific installation direction. Check the direction.

4. Remove the stop ring from the one-shaft housing Assy.

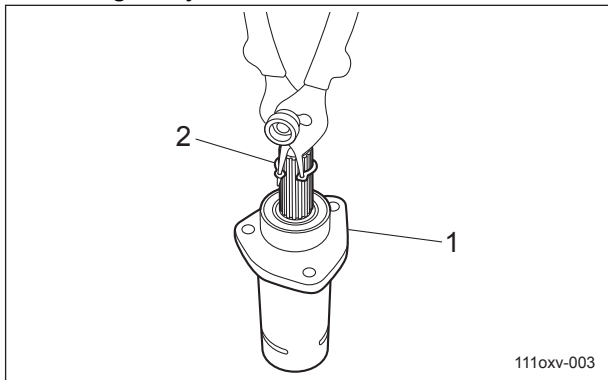

One-shaft Housing_003

1	One-shaft housing Assy
2	Stop ring

5. Hold the one-shaft housing Assy, knock the one-shaft with a wood hammer, and remove the ball bearing and one-shaft.

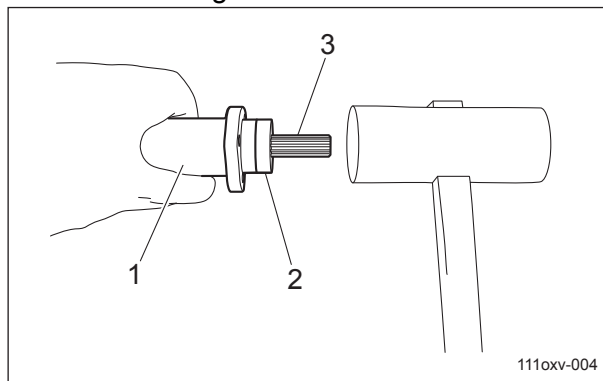

One-shaft Housing_004

1	One-shaft housing Assy
2	Ball bearing
3	One shaft

6. Lightly knock the needle bearing in the direction of the arrow with a pipe etc. to remove the needle bearing and oil seals.

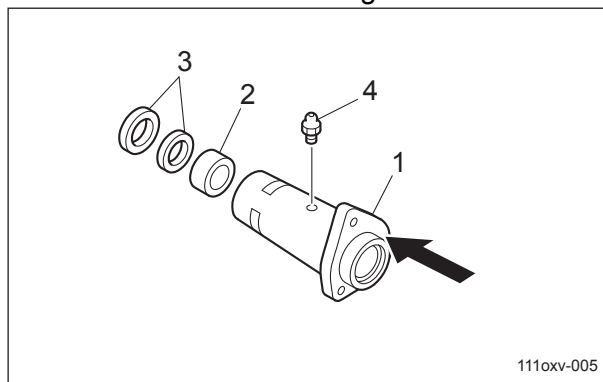

One-shaft Housing_005

1	One-shaft Housing
2	Needle bearing
3	Oil seal
4	Grease nipple

Operating Machine and Mower Units

Important

Be sure to replace the oil seals and bearings with new ones.

- Apply a profuse amount of grease to new bearings and oil seals.
To bearings, apply grease like rubbing until the grease leaks from the other side.
Also apply a profuse amount of grease to the lip of the oil seal.

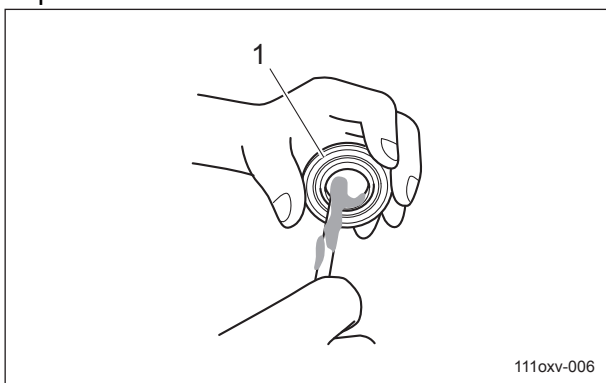

One-shaft Housing_006

1	Oil seal
---	----------

- Install the oil seals back to back so that the rib faces outward.

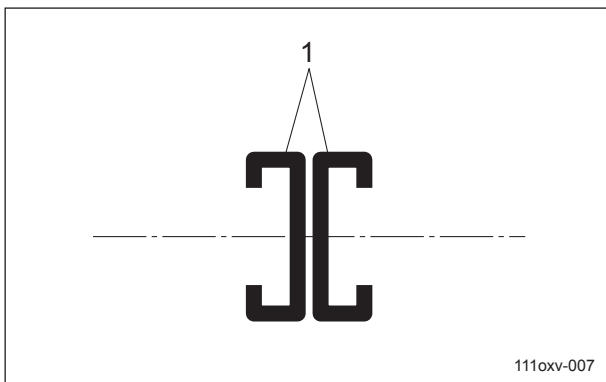

One-shaft Housing_007

1	Oil seal
---	----------

- Tap the needle bearing and oil seal evenly into the one-shaft housing.

Note:

Use a bearing driver to drive in the bearings and oil seals.

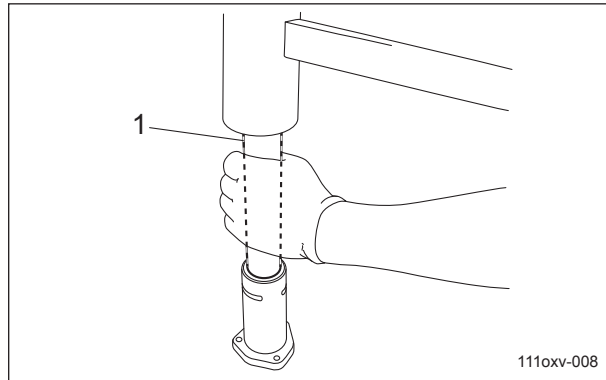

One-shaft Housing_008

1	Installer
---	-----------

Important

Lightly tap the bearing.
If you tap it strongly, the flexible wire insertion opening is damaged and the inner cannot fit.

- Follow the steps below to install the one-shaft.
 - Insert the one-shaft into the one-shaft housing.
 - Insert the pipe in the lower part to prevent the one-shaft from falling.

Operating Machine and Mower Units

[3] Tap the ball bearing from above.

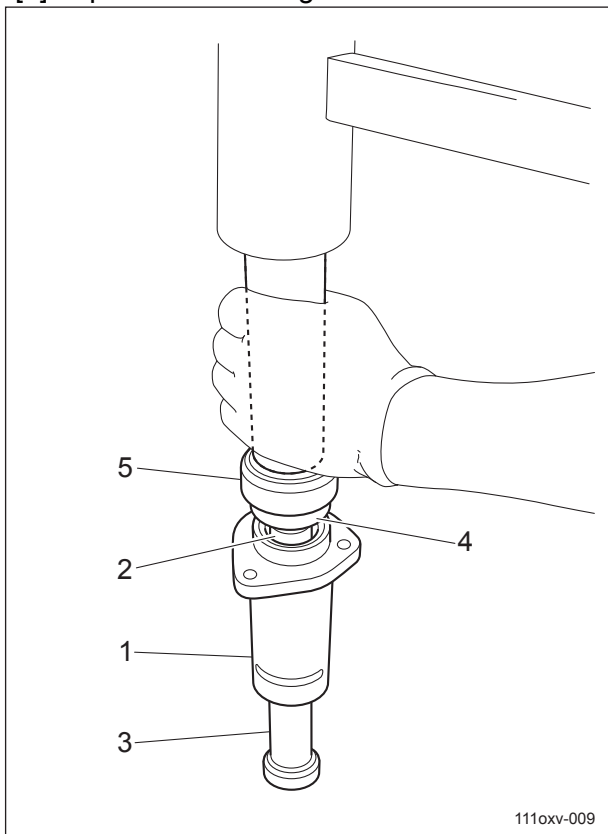

One-shaft Housing_009

1	One-shaft Housing
2	Mower shaft
3	Pipe
4	Ball bearing
5	Installer

Important

The stop ring has a specific installation direction. Install it in the correct orientation.

11. Install the stop ring onto the one-shaft housing Assy.

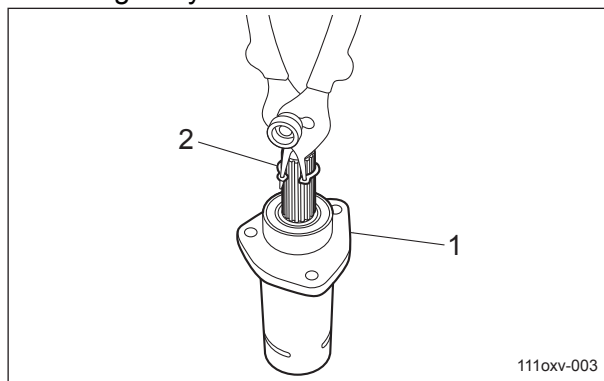

One-shaft housing Assy_010

1	One-shaft housing Assy
2	Stop ring

12. Apply grease from the grease nipple.

13. Install the one-shaft housing packing and one-shaft housing Assy onto the mower unit, and then install the bearing retaining washer and flathead screw.

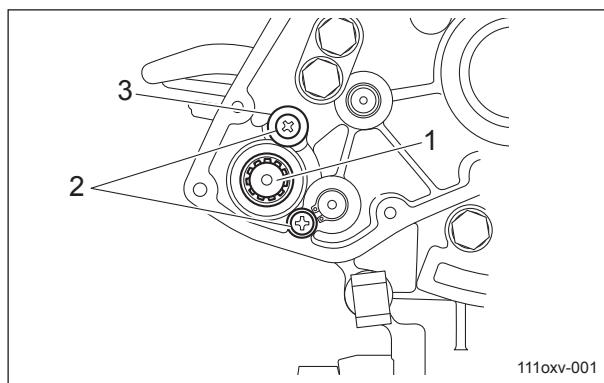

One-shaft housing Assy_011

1	One-shaft housing Assy
2	Flathead screw
3	Bearing retaining washer

Operating Machine and Mower Units

Transmission Gear

Wear of needle bearings due to frequent use and/or damage of needle bearing etc. caused by invasion of water may prevent smooth rotation of the transmission gear.

Inspect and replace the parts such as the needle bearings and gears.

- Make sure that there is no wear of the reverse nor intermediate shaft.
- Make sure that the gears are not damaged nor worn.

Caution

The reel cutter (cutting cylinder), bed knife (bottom blade), and groomer blades are all edged tools.

Handle them carefully, since they could cut your hands and feet.

1. Remove the mower unit from this machine and turn it up.
2. Remove the reel reverse lever. (See "Removal of Reel Cutter" (Page 7-13) ".)
3. Remove the gear cover. (See "Removal of Reel Cutter" (Page 7-13) ".)
4. Follow the steps below to remove the gears.

[1] Remove the washers attached to the intermediate and reverse gears.

Note:

- The washers of washer set A are installed in the order of copper, iron, and copper from the gear side.
- The washers of washer set B are installed in the order of copper and iron from the gear side.

[2] Remove the intermediate, reverse and reel gears.

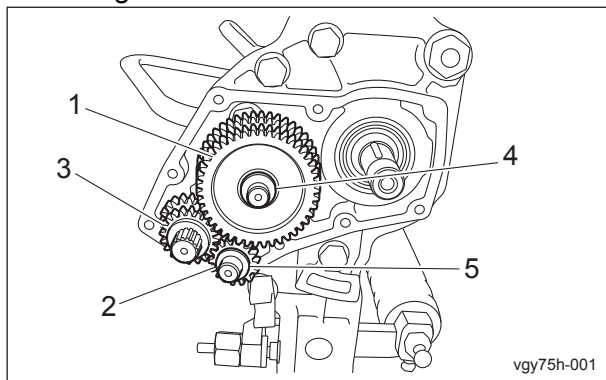

Transmission Gear_001

1	Intermediate gear
2	Reverse gear
3	One-shaft gear
4	Washer set A
5	Washer set B

5. Remove the washers and collars attached to the intermediate and reverse shafts.

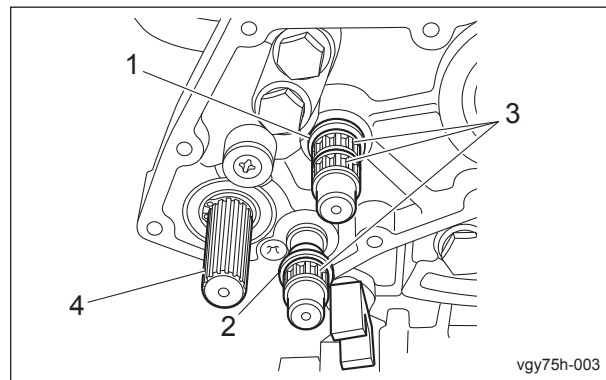

Transmission Gear_002

1	Washer
2	Collar
3	Needle bearing
4	One-shaft

Important

Be sure to replace the bearing with new one.

6. Apply a profuse amount of grease to the new bearing.
To bearings, apply grease like rubbing until the grease leaks from the other side.
7. Install the washers and collars onto the intermediate and reverse shafts.

Operating Machine and Mower Units

8. Apply grease to the one-shaft.

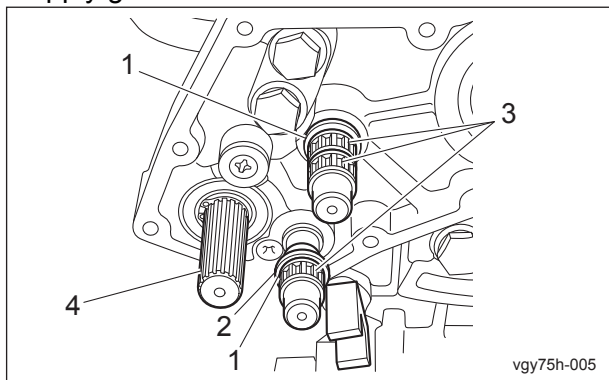

Transmission Gear_003

1	Washer
2	Collar
3	Needle bearing
4	One-shaft

1	Intermediate gear
2	Washer set A
3	Reverse gear
4	Washer set B
5	Mower shaft
6	One-shaft gear

Important

The reverse gear has a specific installation direction. Its teeth are chamfered to fit those of the one-shaft gear, so be sure not to install it in a wrong direction.

9. Follow the steps below to install the gears.

[1] For installation, reverse the procedure to remove the gear.

Note:

- The washers of washer set A are installed in the order of copper, iron, and copper from the gear side.
- The washers of washer set B are installed in the order of copper and iron from the gear side.

[2] Install the washers onto the intermediate and reverse shafts.

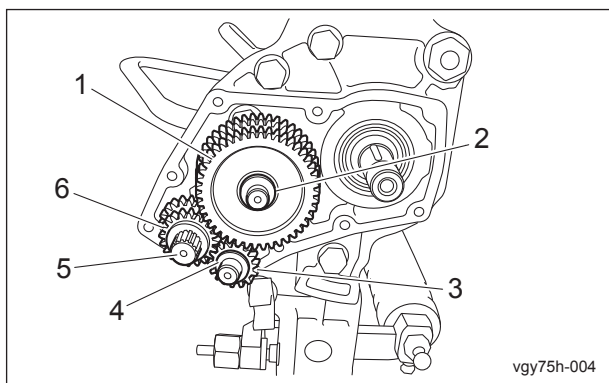

Transmission Gear_004

Bed Knife

The bed knife (bottom blade) may become chipped or dull due to frequent use, sand crushed during mowing, or damage caused during transportation.

Inspect it, and if necessary, replace the bed knife or bed knife mounting.

- Make sure that the edge of the bed knife is not blunt or waved.
- If the bed knife is worn too much, replace it.

⚠ Danger

The reel cutter (cutting cylinder), bed knife (bottom blade), and groomer blades are all edged tools. Handle them carefully, since they could cut your hands or legs.

⚠ Caution

See the list in "Tightening torques" (Page 3-6)". Note that the Baroness product warranty may not apply to defects caused by incorrect tightening etc.

1. Remove the bed knife mounting Assy from the mower unit. (See "Removal of Bed Knife Mounting Assy" (Page 7-10) .)

Operating Machine and Mower Units

Caution

Before operation, place the bed knife mounting Assy on a stable stage.

2. Remove the screws and then the bed knife from the bed knife mounting.

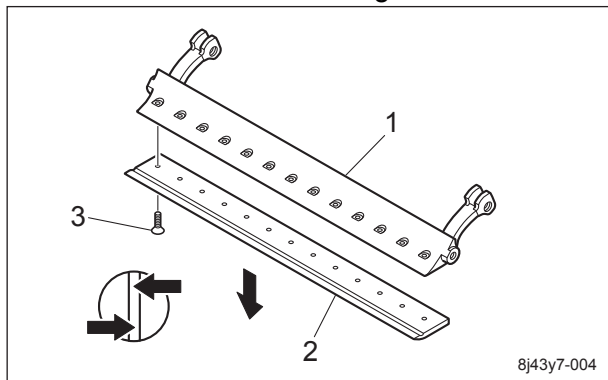

Bed Knife_001

1	Bed knife mounting
2	Bed Knife
3	Screw

3. Keep the knife mounting surface of the bed knife mounting clean by stripping rust etc. being careful not to scratch the surface.

Important

Be sure to replace the screws with new ones.

4. Install a new bed knife onto the bed knife mounting with screws by tightening alternating the right and left ones in order from the two center ones.

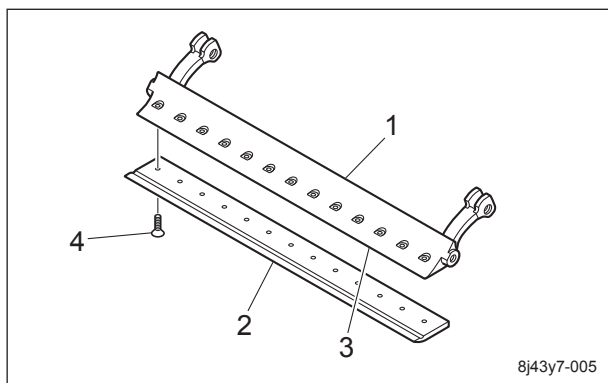

Bed Knife_002

1	Bed knife mounting
2	Bed Knife
3	Bed knife mounting surface
4	Screw

Note:

In the screw installation order, No.1 is tightened first and then outward alternating the right and left ones in order.

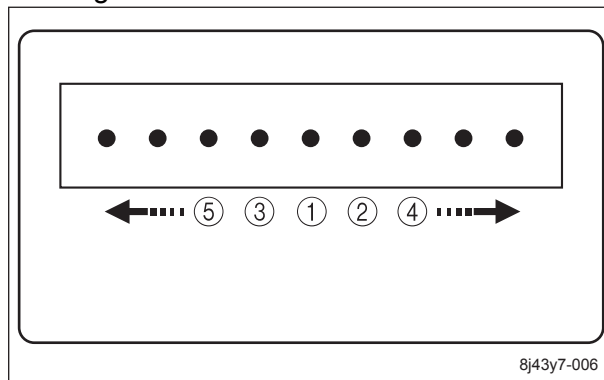

Bed Knife_003

5. Install the bed knife mounting Assy. (See "Installation of Bed Knife Mounting Assy" (Page 7-12) ".)

Roller

Front Roller

Wear of bearings due to frequent use and/or damage of bearing etc. caused by invasion of water may prevent smooth rotation of the roller. Inspect and replace the parts such as the oil seal or bearings.

- Make sure that there is no play in the fit of the roller pipe and the housing.
- Make sure that there is no abrasion or adhesion of the roller.
- Make sure that there is no abrasion or rust of the bearing and the housing and bearing have no play.

Danger

The reel cutter (cutting cylinder), bed knife (bottom blade), and groomer blades are all edged tools. Handle them carefully, since they could cut your hands and feet.

Caution

See the list in "Tightening torques" (Page 3-6) ". Note that the Baroness product warranty may not apply to defects caused by incorrect tightening etc.

1. Remove the front roller Assy.

Operating Machine and Mower Units

2. Remove the oil seal and stop ring on the left and right sides.

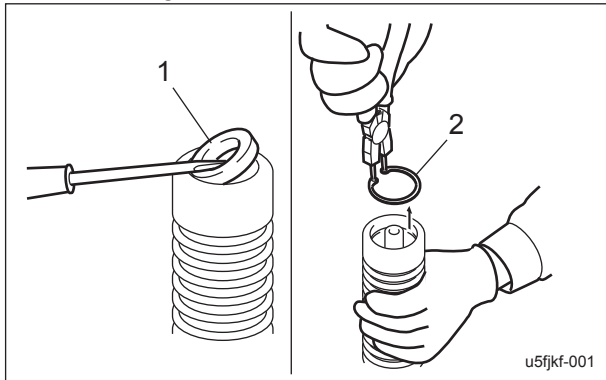

Front Roller_001

1	Oil seal
2	Stop ring

3. Knock the side where the protruding roller shaft is longer to remove the roller shaft.

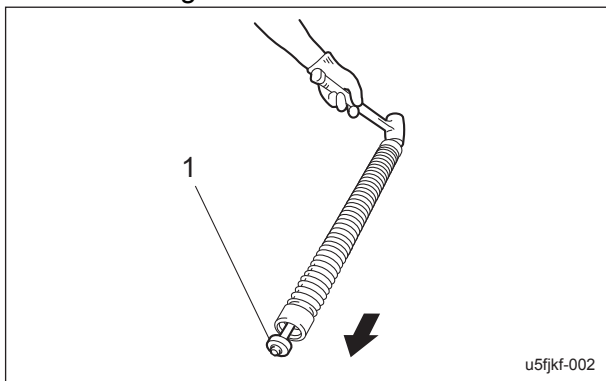

Front Roller_002

1	Roller shaft
---	--------------

4. Fix the removed roller shaft with a vise etc. and then remove the bearing by using a pulley remover.

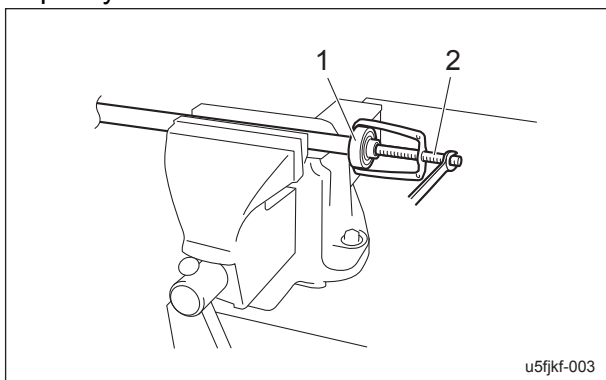

Front Roller_003

1	Bearing
2	Pulley remover

5. Follow the same steps again to insert the roller shaft into the roller and remove the bearing and washer on the opposite side.

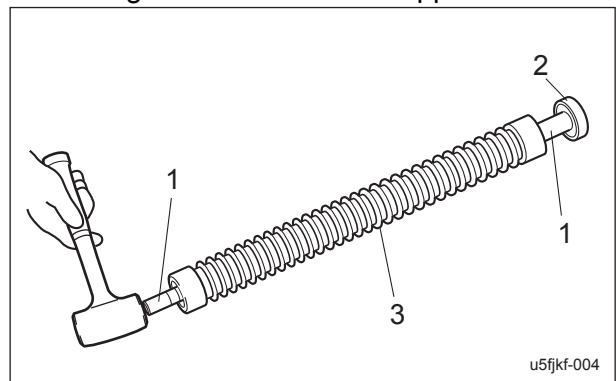

Front Roller_004

1	Roller shaft
2	Bearing
3	Roller

Important

Be sure to replace the bearings and oil seals with new ones.

6. Apply a profuse amount of grease to new oil seals.

Also apply a profuse amount of grease to the lip of the oil seal.

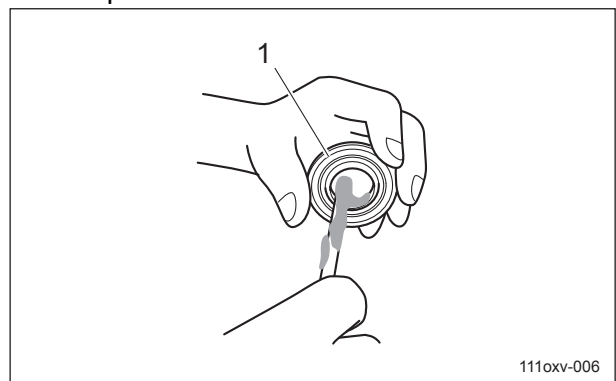

Front Roller_005

1	Oil seal
---	----------

Operating Machine and Mower Units

Important

The bearing is double-sealed.
Be careful not to damage the seal of the bearing itself when driving in.

7. Tap the bearing into the oil seal.

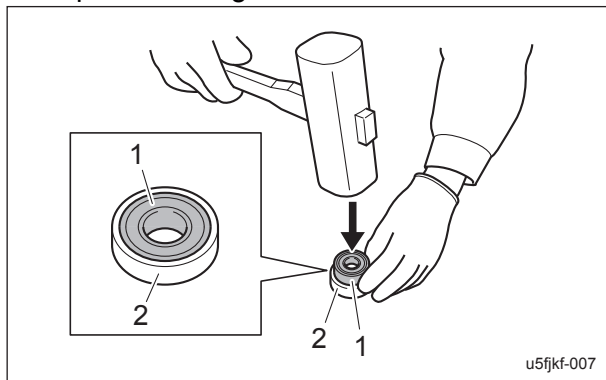

Front Roller_006

1	Bearing
2	Oil seal

Important

Be sure to replace the oil seal with new ones.
Tap the bearing and oil seal firmly down to the groove level of the stop ring.

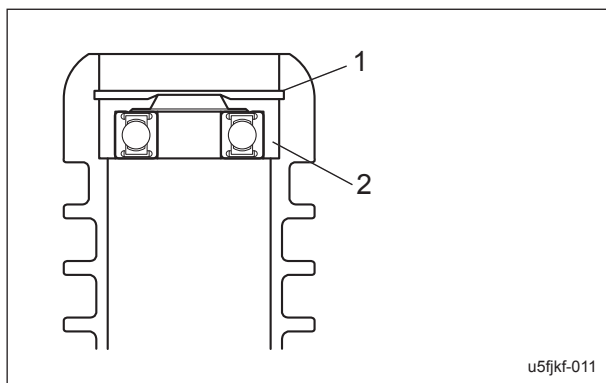

Front Roller_007

1	Stop ring groove
2	Oil seal

8. Tap evenly the part, in which the bearing is tapped into the oil seal, on one side of the roller.

Note:

Use a bearing driver to drive in the bearings and oil seals.

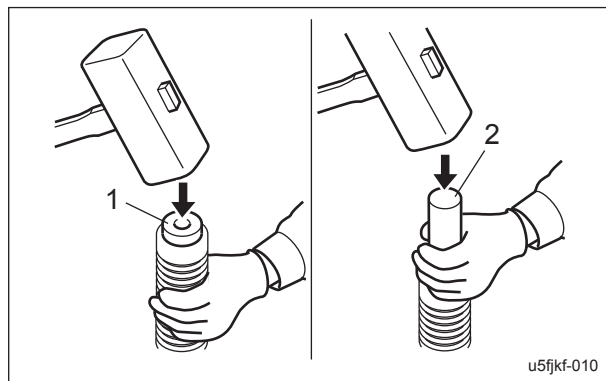

Front Roller_008

1	Bearing + Oil seal
2	Installer

9. Attach the stop ring.

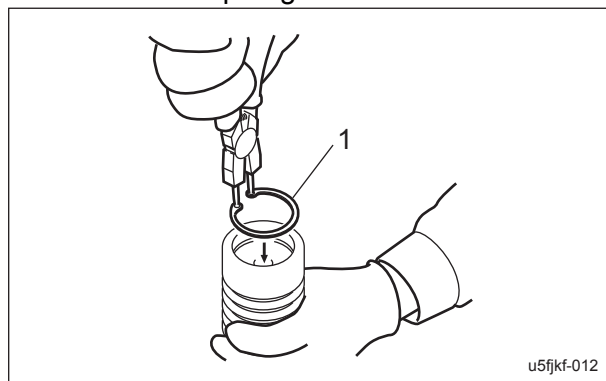

Front Roller_009

1	Stop ring
---	-----------

Operating Machine and Mower Units

10. Apply a profuse amount of grease to new oil seals.

Also apply a profuse amount of grease to the lip of the oil seal.

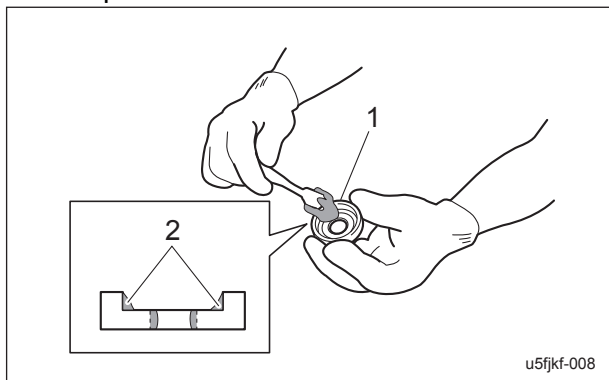

Front Roller_010

1	Oil seal
2	Grease

11. Tap the oil seal into the end of the roller.

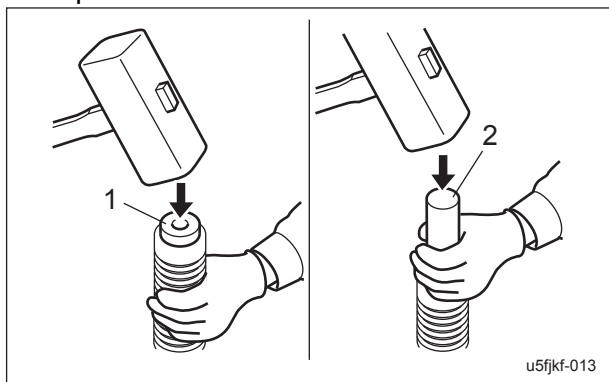

Front Roller_011

1	Oil seal
2	Installer

12. Follow the steps below to install the roller shaft.

[1] Install the washer on the shorter stepped portion of the roller shaft.

[2] Insert the roller shaft from the side where the bearing of the roller is not installed.

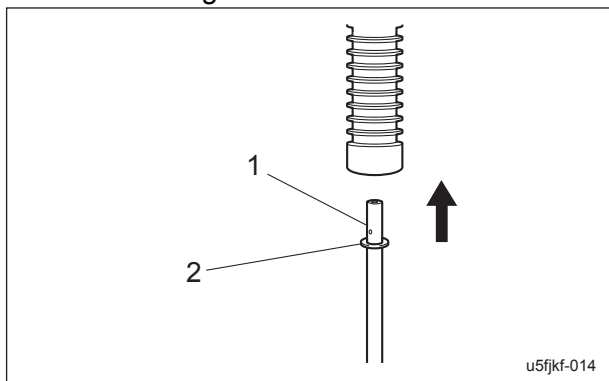

Front Roller_012

1	Roller shaft
2	Washer

[3] Reverse the roller with the roller shaft installed and then install the washer onto the shaft on the opposite side.

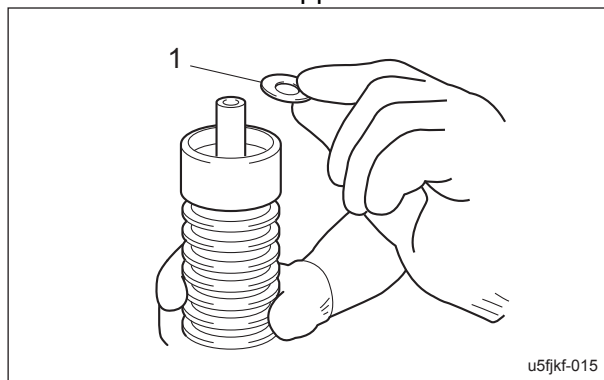

Front Roller_013

1	Washer
---	--------

13. Follow the same steps to install the bearing, oil seal, and stop ring on the opposite side.

14. Make sure that the roller rotates smoothly with no play when the roller shaft is fixed.

15. Install the front roller Assy. "Installation of Front Roller Assy" (Page 7-18)

Rear roller

Wear of bearings due to frequent use and/or damage of bearing etc. caused by invasion of water may prevent smooth rotation of the rear roller.

Inspect and replace the parts such as the oil seal or bearing.

- Make sure that there is no abrasion or adhesion of the roller.
- Make sure that there is no abrasion or rust of the bearing and the housing and bearing have no play.

Operating Machine and Mower Units

⚠ Danger

The reel cutter (cutting cylinder), bed knife (bottom blade), and groomer blades are all edged tools. Handle them carefully, since they could cut your hands and feet.

⚠ Caution

See the list in " "Tightening torques" (Page 3-6) ". Note that the Baroness product warranty may not apply to defects caused by incorrect tightening etc.

1. Remove the rear roller Assy. (See " "Removal of Rear Roller Assy" (Page 7-19) ".)
2. Knock the roller shaft out with a wood hammer.

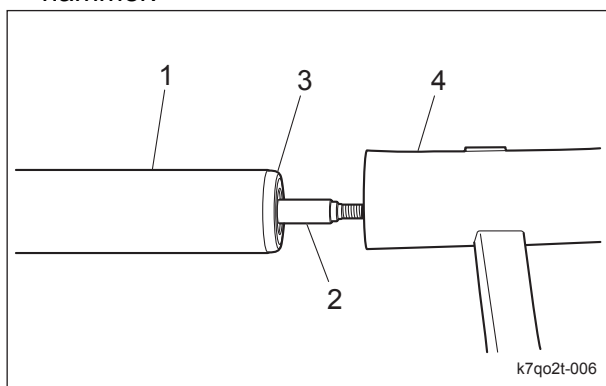

Rear Roller_001

1	Roller
2	Roller shaft
3	Roller housing Assy
4	Wood hammer

3. Remove the roller housing Assy from the roller shaft.

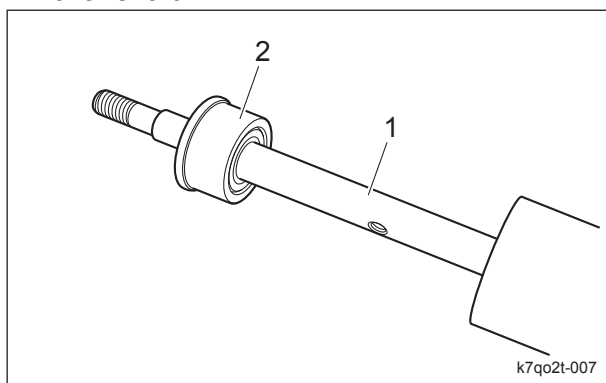

Rear Roller_002

1	Roller shaft
2	Roller housing Assy

4. Fix the roller housing Assy with the vise etc., and knock oil seal A, bearing, and oil seal B out with the pipe of outer $\phi 19$ and a wood hammer.

Note:

When using the vise, open it a little wider than the outer diameter of the bearing.

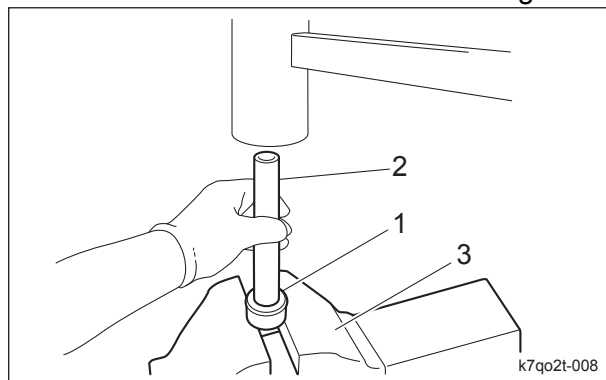

Rear Roller_003

1	Roller housing Assy
2	Pipe
3	Vise

5. Follow the same steps again to insert the roller shaft into the roller and remove the roller housing Assy on the opposite side.

Operating Machine and Mower Units

Important

Be sure to replace the bearings and oil seals with new ones.

- Apply a profuse amount of grease to new oil seals.
Also apply a profuse amount of grease to the lip of the oil seal.

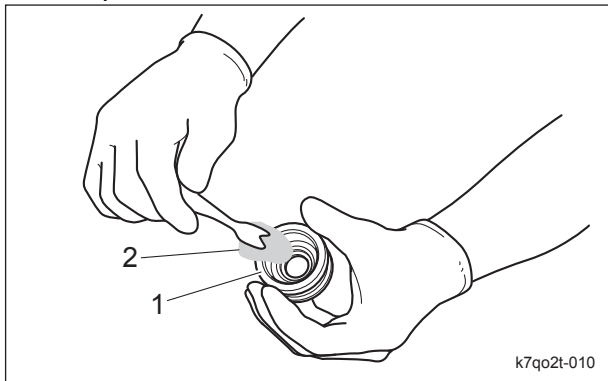

Rear Roller_005

1	Oil seal
2	Grease

- Position the rib of the oil seal facing toward the bearing and install it onto the roller housing.

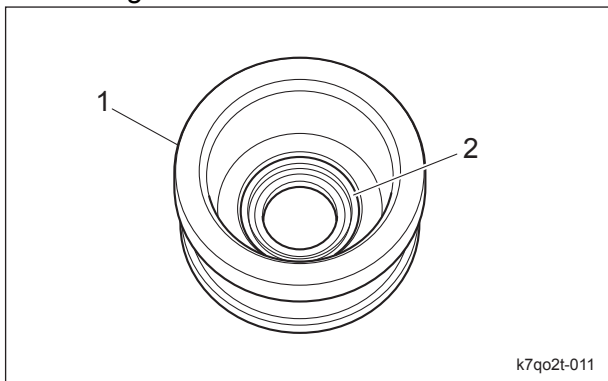

Rear Roller_006

1	Roller housing
2	Oil seal

- Tap the bearing into the roller housing evenly.
Note:
Use a bearing driver to drive in the bearings.

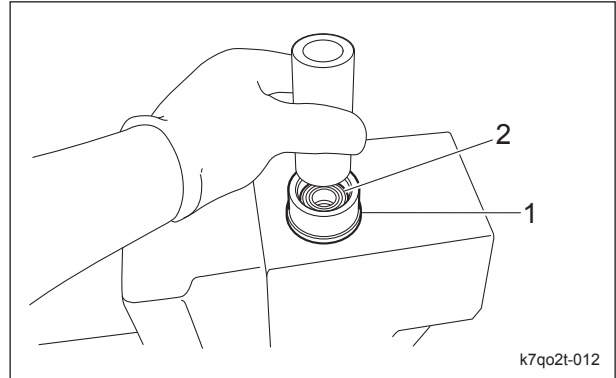

Rear Roller_007

1	Roller housing
2	Bearing

- Tap the oil seal into the roller housing evenly.
Note:
Use a bearing driver to drive in the oil seals.

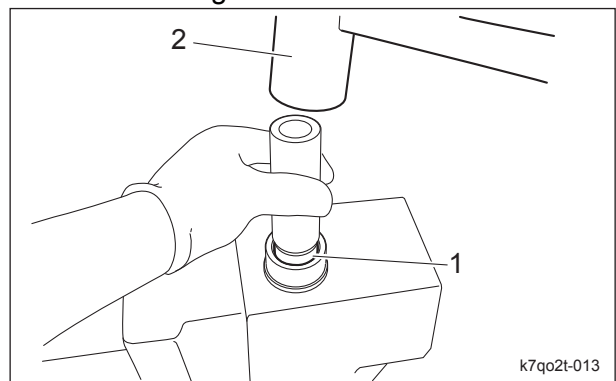

Rear Roller_008

1	Oil seal
2	Wood hammer

- Knock the roller housing Assy onto one side of the roller with a wood hammer.

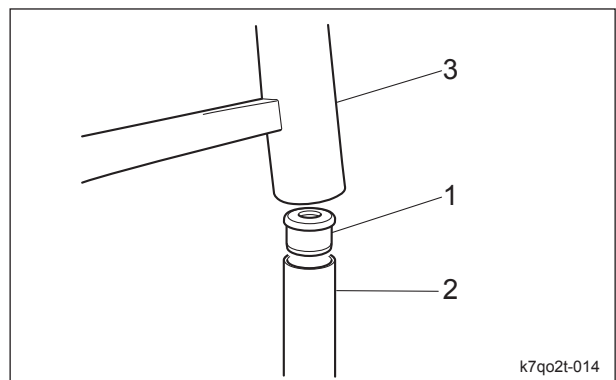

Rear Roller_009

Operating Machine and Mower Units

1	Roller housing Assy
2	Roller
3	Wood hammer

11. Insert the roller shaft into the roller from the opposite side to the side where the roller housing Assy was knocked.

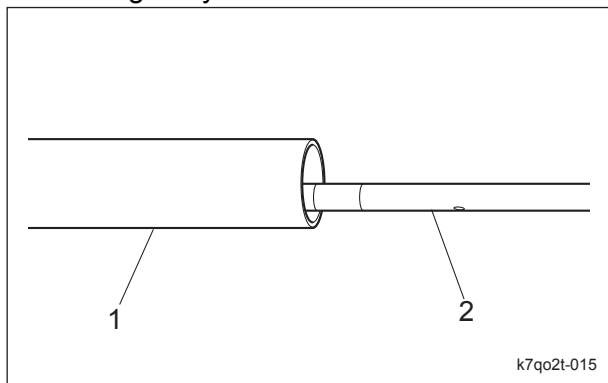

Rear Roller_010

1	Roller
2	Roller shaft

12. Use the installer to knock the roller housing Assy with a wood hammer.

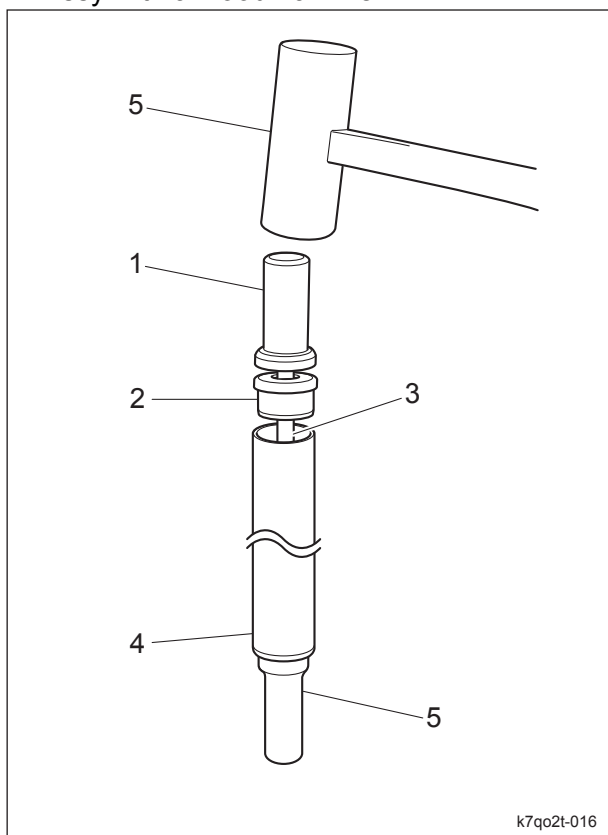

Rear Roller_011

1	Installer
2	Roller housing Assy
3	Roller shaft
4	Roller
5	Wood hammer

13. Make sure that the roller rotates smoothly with no play when the roller shaft is fixed.

14. Install the rear roller Assy. (See "Installation of Rear Roller Assy" (Page 7-19) ".)

Grass catcher roller Assy

Wear of bearings due to frequent use and/or damage of bearing etc. caused by invasion of water may prevent smooth rotation of the roller. Inspect and replace the parts such as the oil seal or bearings.

- Make sure that there is no abrasion or adhesion of the roller.
- Make sure that there is no abrasion or rust of the bearing and the housing and bearing have no play.

⚠ Danger

The reel cutter (cutting cylinder), bed knife (bottom blade), and groomer blades are all edged tools. Handle them carefully, since they could cut your hands and feet.

⚠ Caution

See the list in "Tightening torques" (Page 3-6) ". Note that the Baroness product warranty may not apply to defects caused by incorrect tightening etc.

1. Remove the grass catcher roller Assy.

Operating Machine and Mower Units

2. Remove the oil seal and stop ring on the left and right sides.

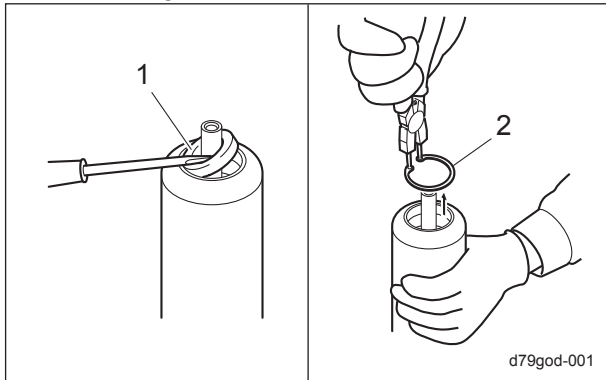

Grass catcher roller Assy_001

1	Oil seal
2	Stop ring

3. Knock one side of the roller with a wood hammer etc. to remove the grass catcher roller shaft.
4. Fix the removed roller shaft with a vise etc. and then remove the bearing by using a pulley remover.

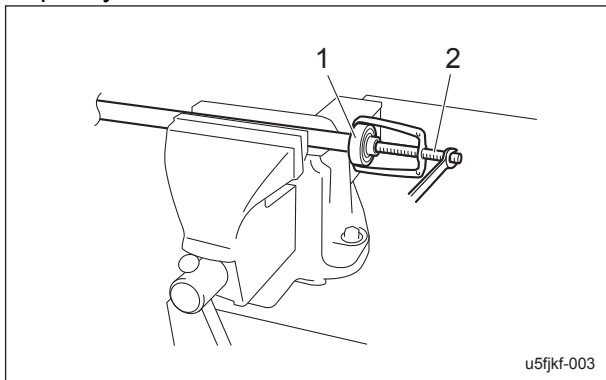

Grass catcher roller Assy_002

1	Bearing
2	Pulley remover

5. Follow the same steps again to insert the roller shaft into the roller and remove the bearing and washer on the opposite side.

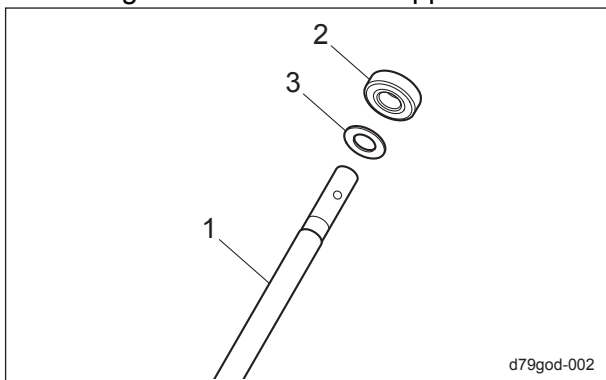

Grass catcher roller Assy_003

1	Roller shaft
2	Bearing
3	Washer

Important

Be sure to replace the bearings and oil seals with new ones.

6. Apply a profuse amount of grease to new oil seals. Also apply a profuse amount of grease to the lip of the oil seal.

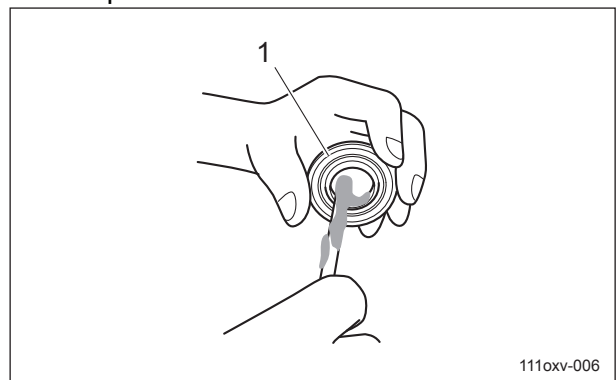

Grass catcher roller Assy_004

1	Oil seal
---	----------

Important

The bearing is double-sealed. Be careful not to damage the seal of the bearing itself when driving in.

7. Tap the bearing into the oil seal.

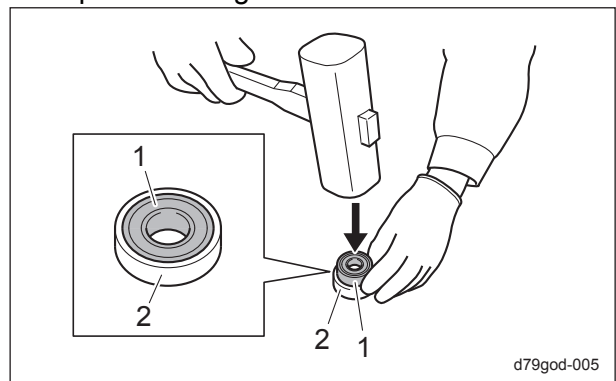

Grass catcher roller Assy_005

1	Bearing
2	Oil seal

Operating Machine and Mower Units

Important

Be sure to replace the oil seal with new ones. Tap the bearing and oil seal firmly down to the groove level of the stop ring.

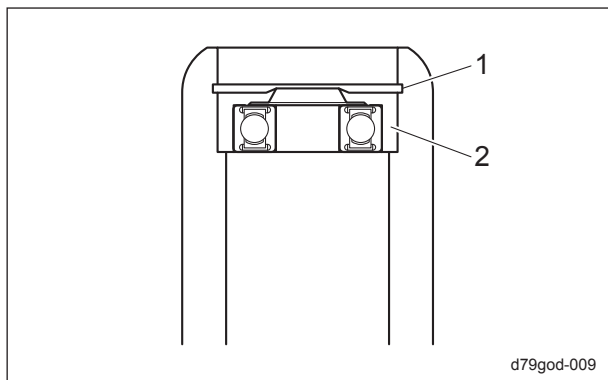

Grass catcher roller Assy_006

1	Stop ring groove
2	Oil seal

8. Tap evenly the part, in which the bearing is tapped into the oil seal, on one side of the roller.

Note:

Use a bearing driver to drive in the bearings and oil seals.

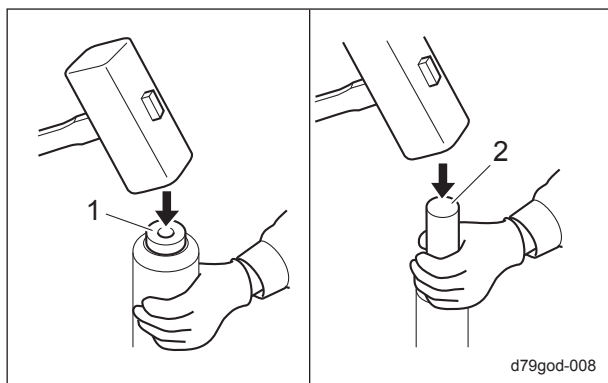

Grass catcher roller Assy_007

1	Bearing + Oil seal
2	Installer

9. Attach the stop ring.

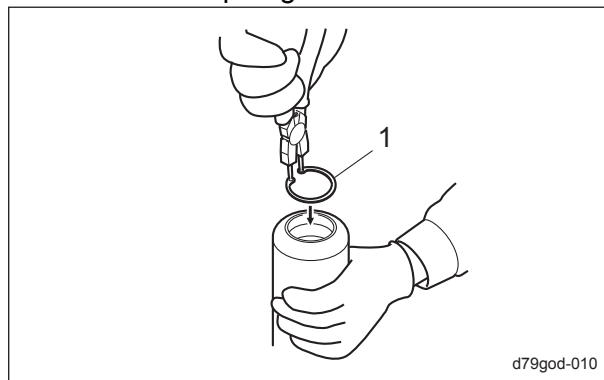

Grass catcher roller Assy_008

1	Stop ring
---	-----------

10. Apply a profuse amount of grease to new oil seals.

Also apply a profuse amount of grease to the lip of the oil seal.

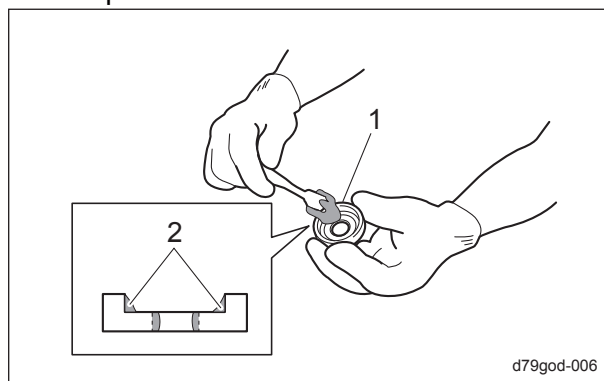

Grass catcher roller Assy_009

1	Oil seal
2	Grease

11. Tap the oil seal into the end of the roller.

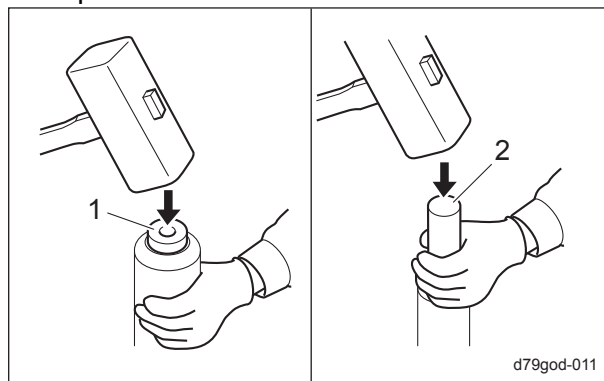

Grass catcher roller Assy_010

1	Oil seal
2	Installer

Operating Machine and Mower Units

12. Follow the steps below to install the roller shaft.

[1] Install the washer onto the stepped portion of the roller shaft on one side of the roller shaft.

[2] Insert the roller shaft from the side where the bearing of the roller is not installed.

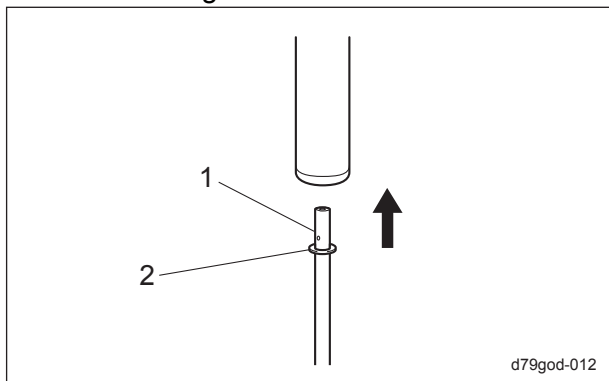

Grass catcher roller Assy_011

1	Roller shaft
2	Washer

[3] Reverse the roller with the roller shaft installed and then install the washer on the opposite side.

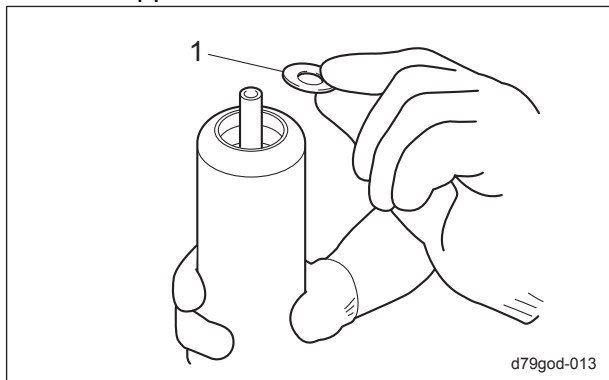

Grass catcher roller Assy_012

1	Washer
---	--------

13. Follow the same steps to install the bearing, oil seal, and stop ring on the opposite side.

14. Make sure that the roller rotates smoothly with no play when the roller shaft is fixed.

15. Install the front roller Assy. "Installation of Grass Catcher Roller Assy" (Page 7-20)

Mower Mounting Bracket

The mower mounting brackets may be bent due to frequent use, damage during transportation, etc.

Inspect it, and if necessary, replace the parts.

- Make sure that the mower mounting brackets are not bent nor damaged.
- Make sure that there is no wear nor rust of the roller shaft receiver.
- Make sure that there is no damage to the spring.
- Make sure that there is no play in the fit of the ball joint and ball joint holder.

⚠ Caution

See the list in "Tightening torques" (Page 3-6).

Note that the Baroness product warranty may not apply to defects caused by incorrect tightening etc.

1. Remove the mower mounting bracket Assy.
2. Remove the cotter pin, stopper, spring, and cap bolt.

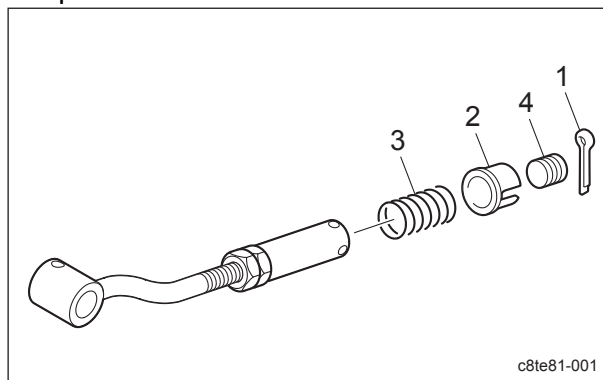

Mower Mounting Bracket_001

1	Cotter pin
2	Stopper
3	Spring
4	Cap bolt

Operating Machine and Mower Units

3. Loosen the nut and remove the ball joint holder.

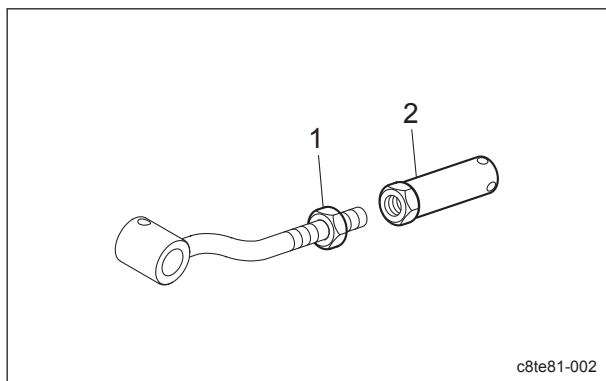

Mower Mounting Bracket_002

1	Nut
2	Ball joint holder

4. Follow the steps below to install the mower mounting bracket.

[1] Adjust it so that the distance between the center of the roller shaft receiver of the mower mounting bracket and the end of the ball joining holder becomes 100.0 mm (3.94 in).

[2] Tighten the nut with the larger notch of the ball joint holder facing downward.

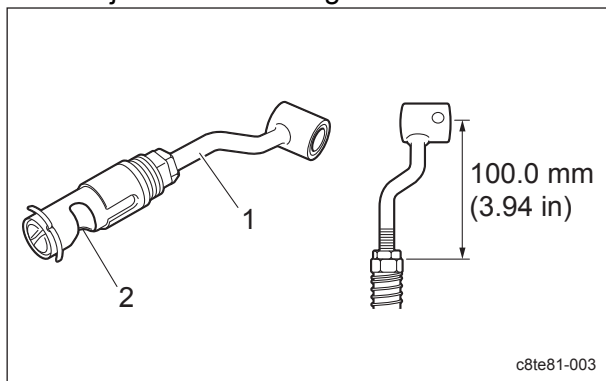

Mower Mounting Bracket_003

1	Mower Mounting Bracket
2	Notch

CR Brush Driver

⚠ Danger

The reel cutter (cutting cylinder), bed knife (bottom blade), and groomer blades are all edged tools. Handle them carefully, since they could cut your hands and feet.

⚠ Caution

See the list in " "Tightening torques" (Page 3-6) ". Note that the Baroness product warranty may not apply to defects caused by incorrect tightening etc.

1. Remove the mower unit and turn it upside down. (See " "Removal of Mower Unit" (Page 7-8) ".)
2. Remove the CR brush driver Assy. (See " "Removal of CR Brush Driver Assy" (Page 7-21) ".)
3. Remove the cover.
4. Follow the steps below to remove the belt.
 - [1] Loosen the nuts securing the tension pulley.
 - [2] Move the tension pulley along with the groove.
 - [3] Remove the belt.

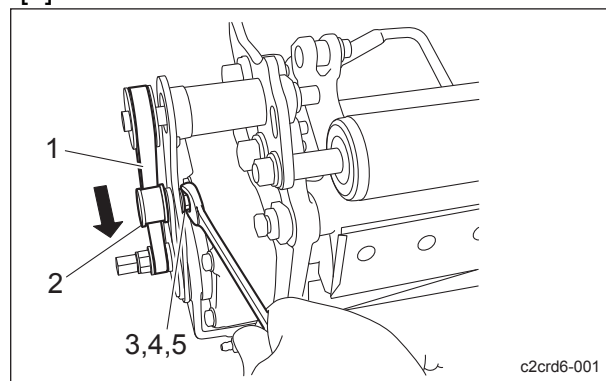

CR Brush Driver_001

1	Belt
2	Pulley Assy
3	Washer
4	Spring washer
5	Nut

Operating Machine and Mower Units

5. Remove the washer, spring washer, and nut from the rear roller bracket.

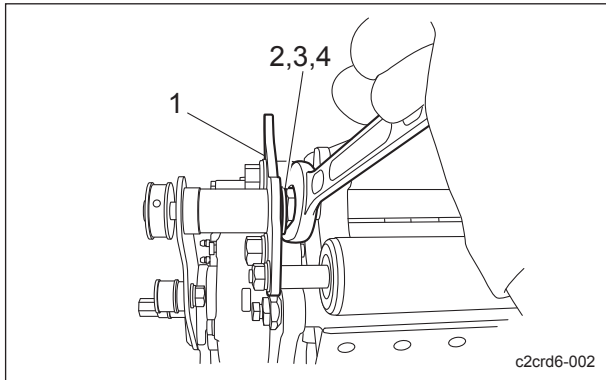

CR Brush Driver_002

1	Rear roller bracket
2	Washer
3	Spring washer
4	Nut

6. Remove the hex socket bolt and spring washer.

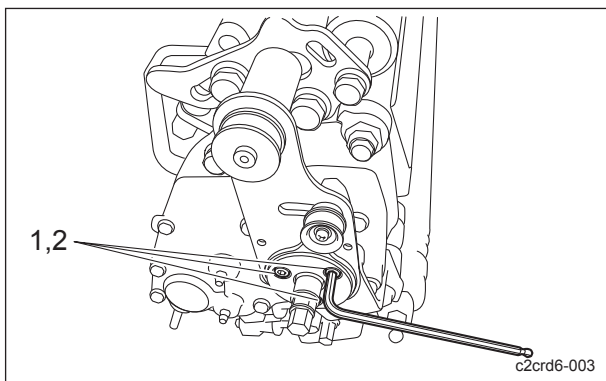

CR Brush Driver_003

1	Hex socket bolt
2	Spring washer

7. Loosen the hollow set screw of the pulley of the brush shaft mounting bracket Assy and then remove the pulley.

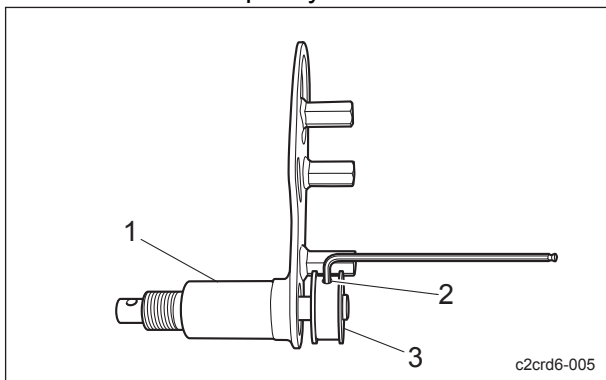

CR Brush Driver_004

1	Brush shaft mounting bracket
2	Hollow set screw
3	Pulley

8. Remove the key and stop ring.

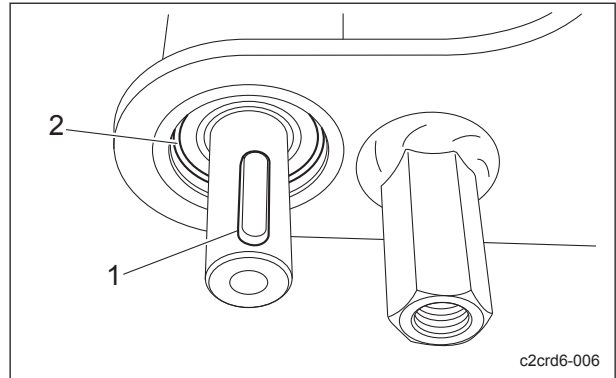

CR Brush Driver_005

1	Key
2	Stop ring

9. Follow the steps below to remove the shaft and bearing.

[1] Knock the brush shaft mounting bracket with a wood hammer to remove the shaft Assy.

[2] Remove the bearing from the shaft Assy.

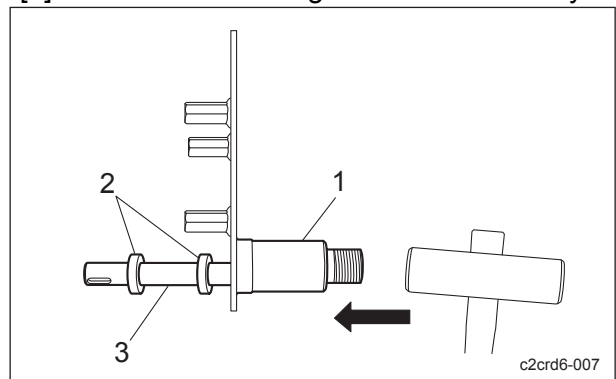

CR Brush Driver_006

1	Brush shaft mounting bracket
2	Bearing
3	Shaft

10. Follow the steps below to remove the pulley from the tension pulley mounting bracket Assy.

[1] Remove the roundhead screw, spring washer, and washer.

[2] Remove the pulley Assy.

[3] Remove the stop ring from the pulley Assy.

Operating Machine and Mower Units

[4] Remove the bearing from the pulley Assy.

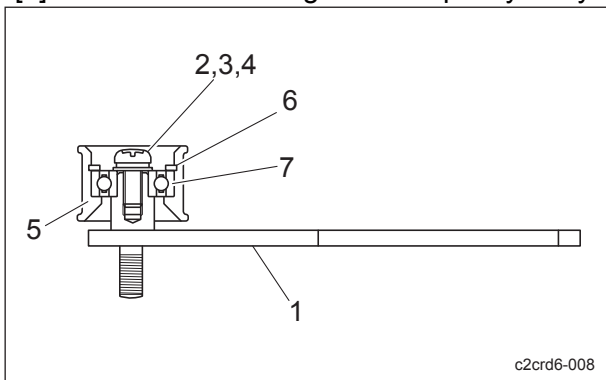

CR Brush Driver_007

1	Tension pulley mounting bracket
2	Roundhead screw
3	Spring washer
4	Washer
5	Pulley
6	Stop ring
7	Bearing

Important

Be sure to replace the bearings and oil seals with new ones.

- Apply a profuse amount of grease to new bearings and oil seals.
To bearings, apply grease like rubbing until the grease leaks from the other side.
Also apply a profuse amount of grease to the lip of the oil seal.

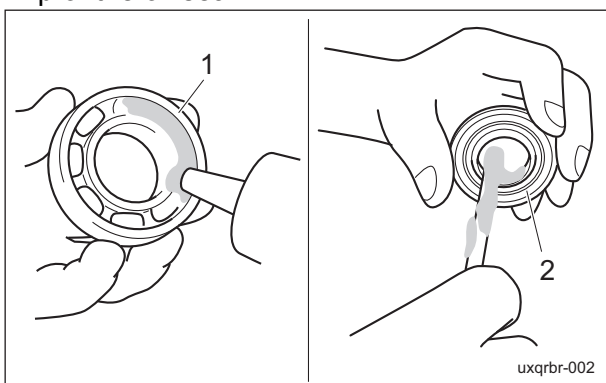

CR Brush Driver_008

1	Ball bearing
2	Oil seal

12. Apply grease to the shaft Assy.

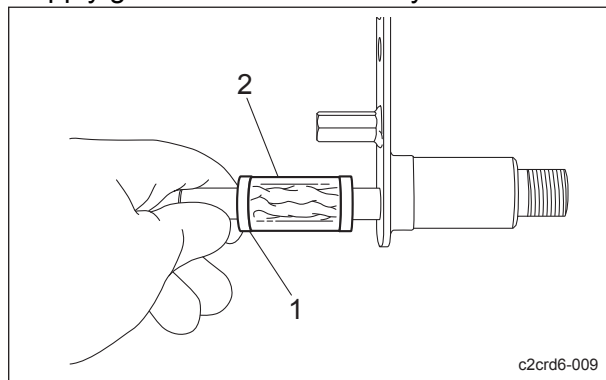

CR Brush Driver_009

1	Shaft Assy
2	Grease

Important

Be careful not to strain the belt too much. Adjust it by the adjustment pulley so that the belt is not slacked, strain it a little more.

- For installing the CR brush driver, reverse the removing procedure.
- Make sure that the driver operates smoothly.
- Install the CR brush driver Assy.

CR Brush

Wear of bearings due to frequent use and/or damage of bearing etc. caused by invasion of water may prevent smooth rotation of the brush. Inspect and replace the parts such as the bearings.

- Make sure that there is no play in the fit of the bearing and the housing.
- Make sure that there is no play in the fit of the brush shaft and the bearing.
- Check the brush for abnormality.

Operating Machine and Mower Units

⚠ Danger

The reel cutter (cutting cylinder), bed knife (bottom blade), and groomer blades are all edged tools. Handle them carefully, since they could cut your hands and feet.

⚠ Caution

See the list in " "Tightening torques" (Page 3-6) ".
Note that the Baroness product warranty may not apply to defects caused by incorrect tightening etc.

1. Remove the CR brush driver Assy. (See " "Removal of CR Brush Driver Assy" (Page 7-21) ".)
 2. If the movement of the bearing of the brush fulcrum metal Assy is bad, follow the steps below to replace the bearing.
- [1] Remove the brush fulcrum metal from the rear roller bracket.

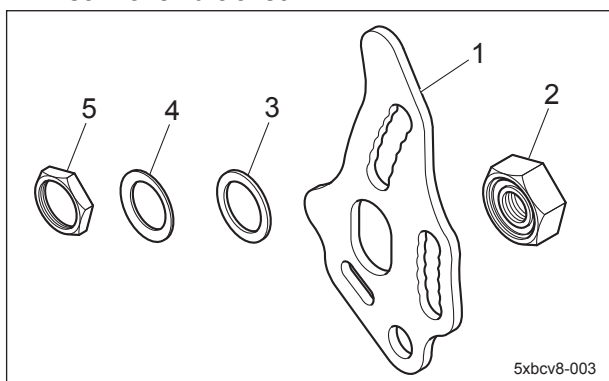

CR Brush_001

1	Rear roller bracket
2	Brush fulcrum metal Assy
3	Washer
4	Spring washer
5	Nut

- [2] Remove the stop ring from the brush fulcrum metal Assy.

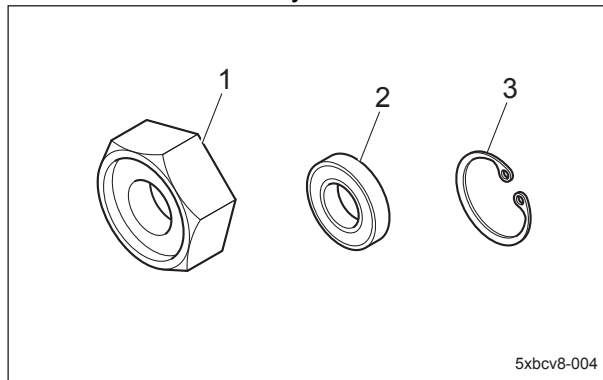

5xbcv8-004

CR Brush_002

1	Brush fulcrum metal
2	Bearing
3	Stop ring

3. For installing the brush fulcrum metal Assy, reverse the removing procedure.
4. Install the CR brush driver Assy. (See " "Installation of CR Brush Driver Assy" (Page 7-22) ".)
5. Make sure that the brush rotates smoothly.

Groomer Assy

Wear of bearings due to frequent use and/or damage of bearing etc. caused by invasion of water may prevent smooth rotation of the groomer.

Inspect and replace the parts such as the oil seal or bearing.

- Make sure that there is no change in shape, breakage, etc. on the groomer blades.
- Make sure that the groomer shaft is not bent nor worn.
- Make sure that there is no crack on the groomer case, groomer cover, nor groomer housing.
- Make sure that the intermediate shaft of the groomer cover has no play.
- Make sure that the bearings and shaft receptacle of the groomer case have no play.
- Make sure that the shifter receptacle of the groomer case has no play.
- Make sure that the bearings receptacle of the groomer housing has no play.

Operating Machine and Mower Units

Caution

The reel cutter (cutting cylinder), bed knife (bottom blade), and groomer blades are all edged tools.

Handle them carefully, since they could cut your feet.

See the list in "Tightening torques" (Page 3-6) .

Note that the Baroness product warranty may not apply to defects caused by incorrect or overtorque tightening etc.

1. Remove the groomer Assy. (See "Removal of Groomer Assy" (Page 7-9) .)
2. Remove the vertical housing Assy.

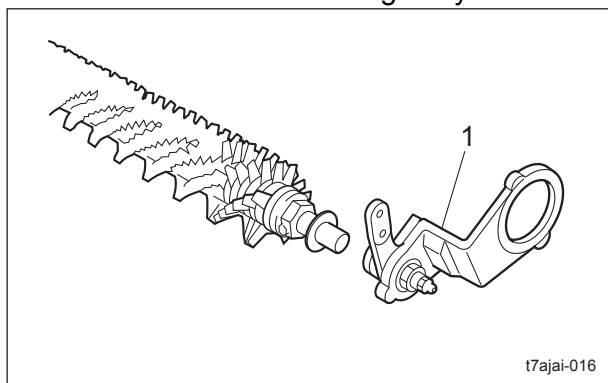

Groomer Assy_001

1	Vertical housing Assy
---	-----------------------

3. Follow the steps below to disassemble the vertical housing.

- [1] Remove the dust-proof cover and washer.
- [2] Remove the screw.
- [3] Remove the oil seal.
- [4] Remove the needle bearing.

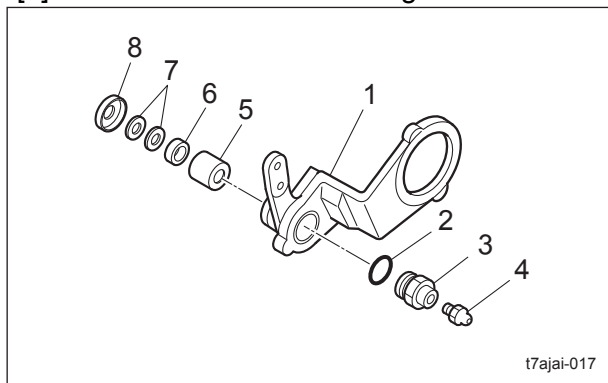

Groomer Assy_002

1	Vertical housing
2	O-ring
3	Screw
4	Grease nipple
5	Needle bearing
6	Oil seal
7	Washer
8	Dust-proof cover

4. Remove the bolt, spring washer and washer, and then remove the clutch holding spring.

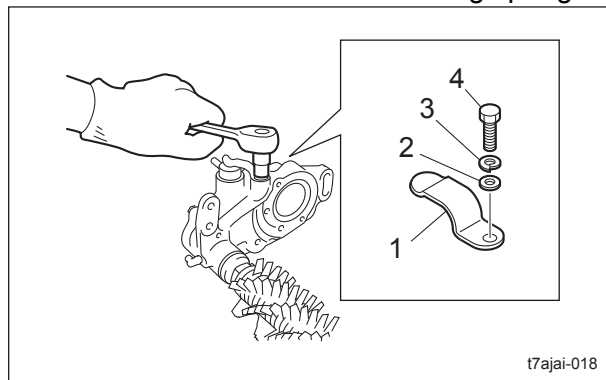

Groomer Assy_003

1	Clutch holding spring
2	Washer
3	Spring washer
4	Bolt

5. Remove the clutch lever.

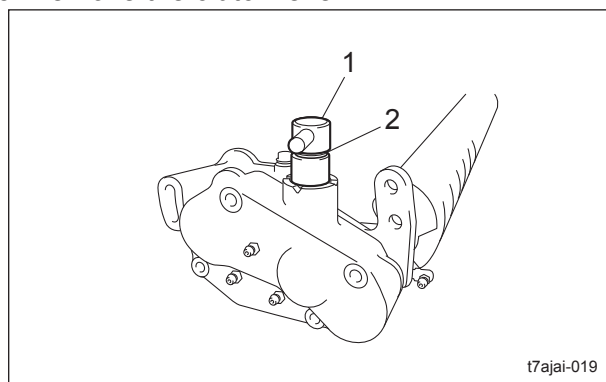

Groomer Assy_004

1	Clutch lever
2	O-ring

Operating Machine and Mower Units

6. Remove the bolt, spring washer and washer of the gear case cover, and then remove the gear case cover.

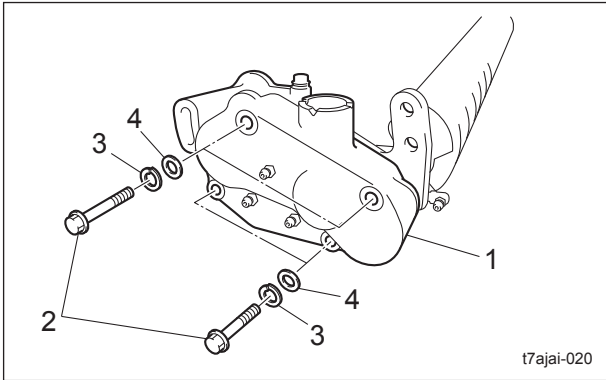

Groomer Assy_005

1	Gear case cover
2	Bolt
3	Spring washer
4	Washer

7. Remove the clutch shaft Assy.

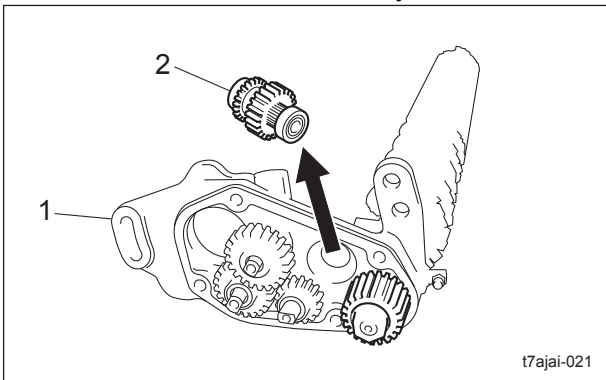

Groomer Assy_006

1	Vertical gear case
2	Clutch shaft Assy

Important

The nut fixing the vertical gear is the left screw.

8. Follow the steps below to remove the groomer shaft Assy.

- [1] Fix the groomer-side nut with a wrench, and then remove the nut and spring washer fixing the vertical gear.
- [2] Remove the vertical gear and collar.

[3] Pull out and remove the groomer shaft Assy in the direction of the arrow.

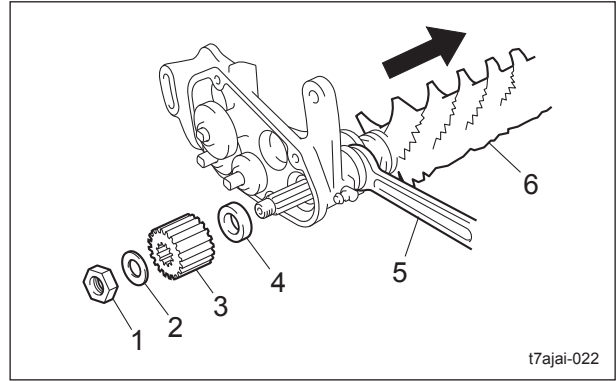

Groomer Assy_007

1	Nut
2	Spring washer
3	Vertical gear
4	Collar
5	Wrench
6	Groomer shaft Assy

Important

The gear has a specific installation direction. Take note of the direction when removing it.

9. Follow the steps below to remove the gear.

- [1] Remove washers A and B attached to the gear.
- [2] Remove the gear and needle bearing.
- [3] Remove washers A and B.

Note:

Washer A (copper), washer B (iron) and washer A (copper) are installed in this order on both of the frame side and the gear case cover side.

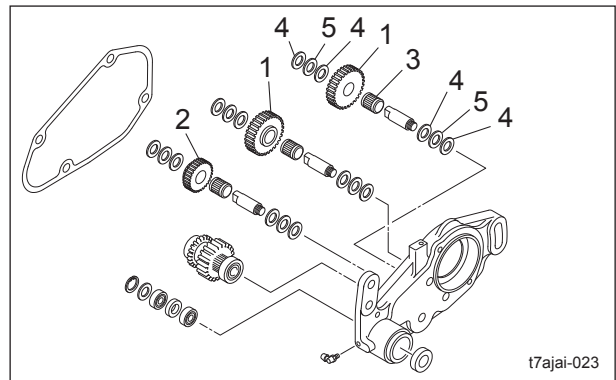

Groomer Assy_008

Operating Machine and Mower Units

1	Gear A
2	Gear B
3	Needle bearing
4	Washer A
5	Washer B

10. Follow the steps below to remove the bearings and oil seals from the vertical gear case.

- [1] Remove the oil seal.
- [2] Remove the stop ring.
- [3] Remove the wave washers, bearings, and collars.

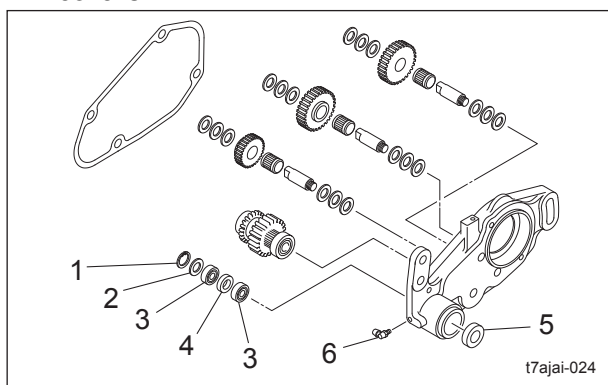

Groomer Assy_009

1	Stop ring
2	Wave washer
3	Bearing
4	Collar
5	Oil seal
6	Grease nipple

11. Loosen the locknut of the special nut on the opposite side to the spline of the groomer shaft, and then loosen the hollow set screw.

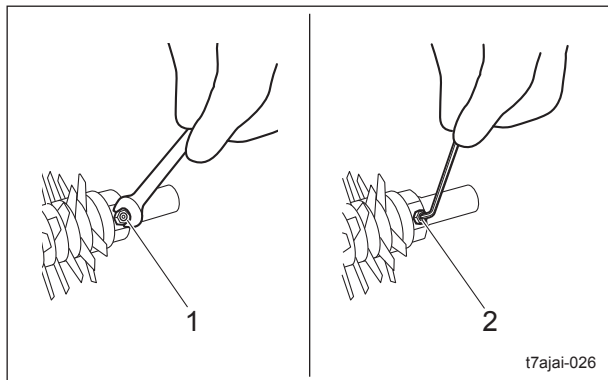

Groomer Assy_010

1	Lock nut
2	Hollow set screw

Important

A spacer (adjustment washer) is installed onto the groomer shaft. Check the position.

12. Follow the steps below to remove the groomer blade from the groomer shaft.

- [1] Fix the special nut on the spline side of the groomer shaft with a wrench, and then remove the special nut on the opposite side.
- [2] Remove the collar and groomer blade.

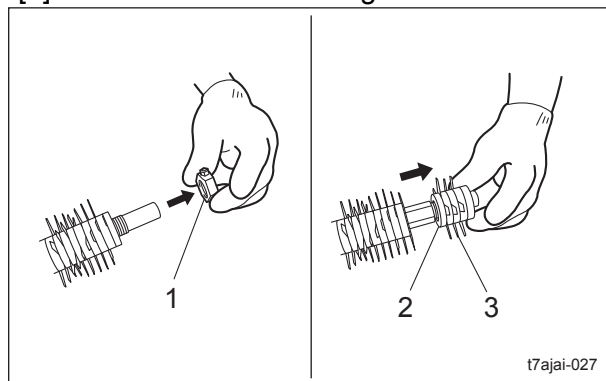

Groomer Assy_011

1	Special nut
2	Collar
3	Groomer blade

13. Remove the special nut on the spline side of the groomer shaft.

Important

Tightening the special nut too much may cause the deflection of the groomer Assy. Be careful not to tighten it too much. (Tightening torque: 5 - 10 N-m)

14. Follow the steps below to install the groomer blade onto the groomer shaft.

- [1] Install the special nut on the spline side of the groomer shaft.
- [2] Make the groomer shaft stand up with the spline side facing downward.
- [3] Install two collars.

Operating Machine and Mower Units

[4] Install the groomer blades and collars one after the other.

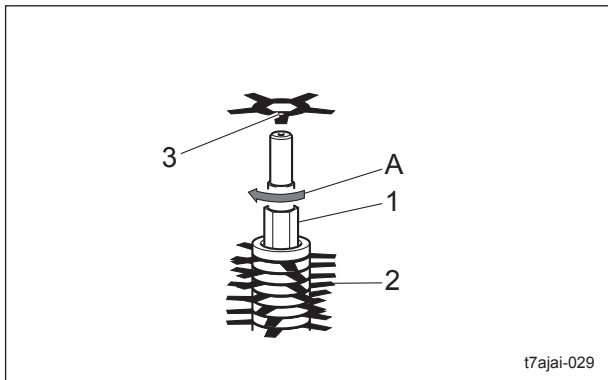

Groomer Assy_012

1	Collar
2	Groomer blade
3	Punch mark
A	Clockwise direction

Note:

Position the punch mark of the groomer blade to face forward. Rotate the groomer shaft by one side of six sides in a clockwise fashion every time you insert one blade.

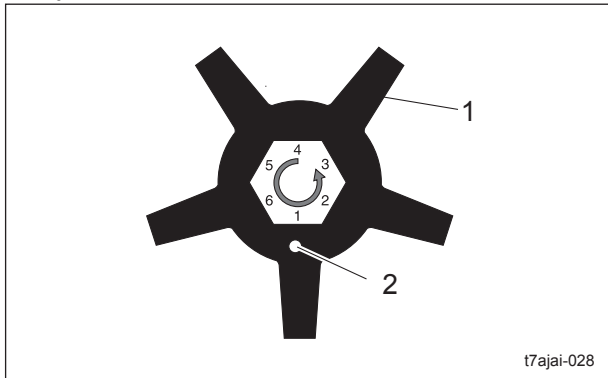

Groomer Assy_013

1	Groomer blade
2	Punch mark

[5] Install two collars.

[6] Tighten the special nut.

[7] Tighten the hollow set screw, and then lock it with the lock nut.

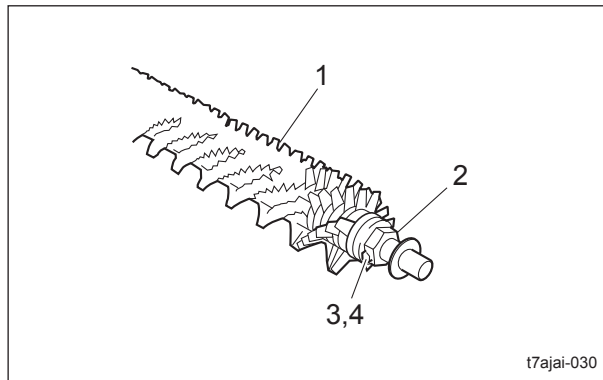

Groomer Assy_014

1	Groomer shaft Assy
2	Special nut
3	Hollow set screw
4	Lock nut

15. Confirm that the twist of the groomer blades is the same as that of the reel cutters.

Important

Be sure to replace the bearings and oil seals with new ones.

16. Apply a profuse amount of grease to new bearings and oil seals.

To bearings, apply grease like rubbing until the grease leaks from the other side.

Also apply a profuse amount of grease to the lip of the oil seal.

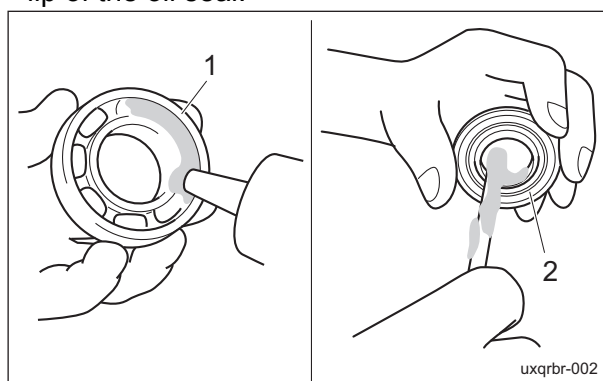

Groomer Assy_015

1	Ball bearing
2	Oil seal

Operating Machine and Mower Units

Important

The gear has a specific installation direction. Do not install it facing the wrong direction.

17. Follow the steps below to install the gear.

- [1] Install washers A and B.
- [2] Install the gear and needle bearing.
- [3] Install washers A and B onto the gear.

Note:

Install washer A (copper), washer B (iron) and washer A (copper) in order in both of frame side and gear case cover side.

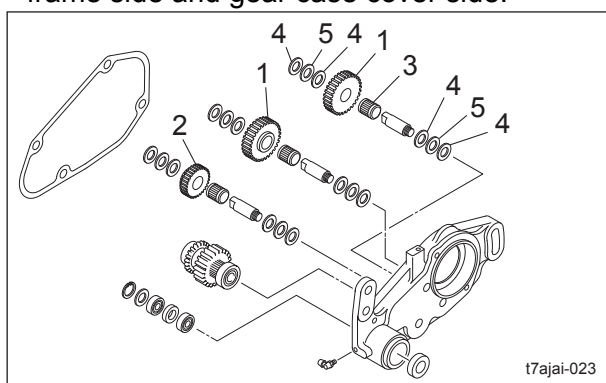

Groomer Assy_016

1	Gear A
2	Gear B
3	Needle bearing
4	Washer A
5	Washer B

18. Follow the steps below to install the bearings and oil seals onto the vertical gear case.

- [1] Install the oil seal.
- [2] Install the wave washers, bearings, and collars.
- [3] Attach the stop ring.

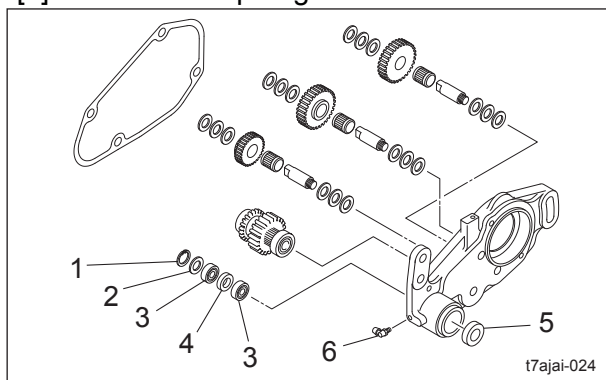

Groomer Assy_017

1	Stop ring
2	Wave washer
3	Bearing
4	Collar
5	Oil seal
6	Grease nipple

19. For installing the groomer shaft Assy onto the vertical gear case, reverse the removing procedure.

Note:

The nut fixing the vertical gear is the left screw.

Important

Confirm that the clutch lever shaft fits into the grooves of the gear of the clutch shaft Assy.

- 20. Install the clutch shaft Assy.
- 21. Install the gear case cover.
- 22. Install the clutch lever and clutch holding spring onto the gear case cover.
- 23. Assemble the vertical housing and install it onto the groomer shaft Assy.
- 24. Install the groomer Assy onto the mower unit. (See "Installation of Groomer Assy" (Page 7-10) ".)
- 25. Confirm that two groomer blades fit into each groove of the front roller.

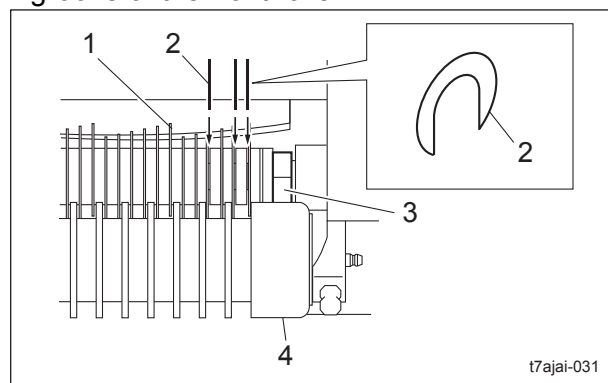

Groomer Assy_018

1	Groomer blade
2	Spacer
3	Special nut
4	Front Roller

Note:

- If the whole groomer blades are inclined to the right or left, adjust them with the left and right special nuts.

Operating Machine and Mower Units

- If the clearance between the roller crests and groomer blades is narrow or they touch each other, adjust them with the spacer (adjustment washer).

Relating to the Engine..... Page 8-2

Relating to Traveling..... Page 8-5

Relating to Steering..... Page 8-7

**Relating to Operating Machine and
Mower Unit..... Page 8-8**

Troubleshooting

Relating to the Engine

Problem	Cause	Reference
The engine does not start (the starter motor does not turn).	The interlock system was activated (not sitting on the seat, parking brake not applied, traveling pedal not neutral and the reel rotation switch not set to the "OFF" position).	Electrical System - Measurements - Interlock System
	Faulty interlock system component (seat switch, parking brake switch, proximity sensor (reel rotation switch), proximity switch or interlock relay unit)	Electrical System - Adjustment Electrical System - Electrical Components
	Faulty 5A/15A fuse	Electrical System - Electrical Components - Fuse Box (A.G)
	Faulty fusible link	Electrical System - Electrical Components - Fusible Link
	Insufficient battery capacity or loose terminals	Electrical System - General Inspections/Repairs - Battery
	Faulty ignition key switch	Electrical system - Electrical equipment - Key switch
	Faulty starter relay	Electrical System - Electrical Components - Starter Relay
	Faulty starter motor	Engine Maintenance Manual
	Overheating or damage to a moving part of the engine	Engine Maintenance Manual
	Malfunction related to electrical wire	Inspect and repair or replace the wire-related part.
The engine does not start (the starter motor turns).	No fuel	Engine Handling Manual
	Clogged fuel filter	Engine Maintenance Manual
	Incorrect fuel	Engine Handling Manual
	Clogged air cleaner element	Engine Maintenance Manual
	Insufficient battery capacity or loose terminals	Electrical System - General Inspections/Repairs - Battery
	Faulty ignition key switch	Electrical system - Electrical equipment - Key switch
	Malfunction of the engine stop solenoid	Engine Maintenance Manual
	No engine compression	Engine Maintenance Manual

Troubleshooting

Problem	Cause	Reference
The engine does not start (the starter motor turns).	Faulty thrust of the starter motor pinion gear	Engine Maintenance Manual
The engine starts, then immediately stops.	The interlock system was activated (left the seat without applying the parking brake).	Electrical System - Measurements - Interlock System
	Clogged air cleaner element	Engine Maintenance Manual
	Little fuel	Engine Handling Manual
	Air in the fuel system	Engine Handling Manual
	Clogged fuel filter	Engine Maintenance Manual
	Malfunction of the engine stop solenoid system	Engine Maintenance Manual
No charge	Loose battery cable	Electrical System - General Inspections/Repairs - Battery
	Corroded battery terminal	Electrical System - General Inspections/Repairs - Battery
	Insufficient battery electrolyte	Electrical System - General Inspections/Repairs - Battery
	Faulty battery	Electrical System - Measurements - Battery Electrical System - General Inspections/Repairs - Battery
	Insufficient fan belt tension	Engine Maintenance Manual
	Disconnected coupler in charging circuit wire or faulty wire	Inspect and repair the wire.
	Faulty alternator	Engine Maintenance Manual
Buzzer warning about overheating sounds	Dust-proof mesh, radiator blocked with dirt or dust	Engine Maintenance Manual
	Insufficient amount of coolant	This machine's Owner's Operating Manual
	Insufficient fan belt tension	Engine Maintenance Manual
	Faulty thermostat	Engine Maintenance Manual
	Malfunction of water temperature sensor	Engine Maintenance Manual
Charge lamp does not turn off	Faulty alternator wire	Inspect and repair the wire.
	Faulty alternator	Engine Maintenance Manual
	Malfunction of the regulator	Replacement of Regulator

Troubleshooting

Problem	Cause	Reference
Oil pressure lamp does not turn off	Insufficient amount of engine oil	This machine's Owner's Operating Manual
	Faulty engine oil switch	Engine Maintenance Manual
	Faulty engine oil pump	Engine Maintenance Manual
Thermo-start (glow) lamp does not turn on	Faulty lamp bulb	Replace the lamp bulb.
	Faulty 5A fuse	Electrical System - Electrical Components - Fuse Box (C)
	Faulty ignition key switch	Electrical system - Electrical equipment - Key switch
	Faulty glow lamp timer	Electrical System - Electrical Components - Glow Lamp Timer

Relating to Traveling

Problem	Cause	Reference
Traveling power is poor.	Engine rpm is slow.	This machine's Owner's Operating Manual
	Engine does not run smooth.	Engine Maintenance Manual
	The parking brake is applied.	This machine's Owner's Operating Manual
	Insufficient adjustment of the throttle wire	Machine - Adjustment - Throttle Wire - Adjustment of Throttle Wire
	Amount of hydraulic oil is low.	This machine's Owner's Operating Manual
	Blockage of the oil filter	Replacement of Oil Filter
	Hydraulic oil is too cool.	This machine's Owner's Operating Manual
	Dirt in the hydraulic oil (contamination, invasion of water, air)	Hydraulic system - Specification - Specifications
	Viscosity of the hydraulic oil is wrong.	Hydraulic system - Specification - Specifications
	Pressure of the piston pump is not high enough.	Hydraulic system - Measurement - Traveling circuit
	Malfunction of the piston pump	Replacement of Piston Pump
It does not travel (in the case without the aforementioned causes).	Malfunction of the wheel motor	Replacement of Piston Pump
	There is no charge pressure of the piston pump.	Hydraulic system - Measurement - Charge circuit
2WD/3WD changeover does not work.	Malfunction of the joint part between the engine and pump	Inspection, repair, or replacement of the joint part
	Malfunction of the 2WD/3WD changeover switch	Electrical system - Electrical equipment - Toggle switch - 2WD/3WD changeover switch
It travels forward or backward even when the pedal is released.	Malfunction of the 2WD/3WD changeover valve	Electrical system - Electrical equipment - Solenoid valve - 2WD/3WD changeover valve
	Malfunction of neutral of the piston pump	Main body - Adjustment - Adjusting the Neutral Position of the Piston Pump
	Malfunction of bearing of neutral lever part	Replacement of the bearing

Troubleshooting

Problem	Cause	Reference
It travels forward or backward even when the pedal is released.	Adhesion or play of the traveling pedal, traveling cable, or piston pump lever part	Main body - Inspection of each part, repair and replacement

Relating to Steering

Problem	Cause	Reference
Power steering is not working (steering operation is heavy)	Engine rpm is slow	This machine's Owner's Operating Manual
	Tire pressure is low	This machine's Owner's Operating Manual
	Amount of hydraulic oil is low.	This machine's Owner's Operating Manual
	Block of suction filter	Replacement of Suction Filter
	Hydraulic oil is too cool.	This machine's Owner's Operating Manual
	Dirt in the hydraulic oil (contamination, invasion of water, air)	Hydraulic system - General Inspections/Repairs
	Viscosity of the hydraulic oil is wrong.	Hydraulic system - Specification - Specifications
	Malfunction of the valve module	Hydraulic system - Measurement - Steering circuit Replacement of valve module
	Malfunction of the orbitrol	Hydraulic system - Measurement - Steering circuit Replacement of the orbitrol
Malfunction of steering cylinder	Replacement of steering cylinder	
Malfunction of the gear pump	Hydraulic system - Measurement - Steering circuit Replacement of the gear pump	

Troubleshooting

Relating to Operating Machine and Mower Unit

Problem	Cause	Reference
The more units cannot be raised	Malfunction of the valve module	Hydraulic system - Measurement - Up/Down circuit Replacement of valve module
	Malfunction of the gear pump	Hydraulic system - Measurement - Up/Down circuit Replacement of the gear pump
	Block of the suction filter	Replacement of Suction Filter
The mower units are raised unintentionally to the maximum extent	Malfunction of proximity sensor	Electrical system - Adjustment - Proximity sensors Electrical system - Electrical equipment - Proximity sensors
	Mower unit control relay unit	Electrical system - Electrical equipment - Mower unit control relay unit
	Malfunction of the valve module	Hydraulic system - Measurement - Up/Down circuit Replacement of Valve Module
The more units get lowered by themselves	Malfunction of the valve module	Hydraulic system - Measurement - Up/Down circuit Replacement of Valve Module
	Malfunction of the up/down cylinder	Hydraulic system - Measurement - Up/Down circuit
The reel cutter does not rotate	Malfunction of the electromagnetic clutch	Electrical system - Adjustment - Electromagnetic clutch Electrical system - Electrical equipment - Electromagnetic clutch
	Malfunction of the flexible wire	Replacement of Flexible Wire
	Malfunction of the proximity sensor	Electrical system - Adjustment - Proximity sensors Electrical system - Electrical equipment - Proximity sensors
	Malfunction of the mower unit control relay unit	Electrical system - Electrical equipment - Mower unit control relay unit
	The reel reverse lever is neutral	Turn the reel reverse lever to normal or reverse
	Malfunction of the transmission	Replacement of Transmission
	Malfunction inside the reel cutter gear case	Operating Machine and Mower Units - Removal and installation of each part - Reel cutter
Reel rotation is slow	Malfunction of the electromagnetic clutch	Electrical system - Adjustment - Electromagnetic clutch Electrical system - Electrical equipment - Electromagnetic clutch
	Insufficient tension of the flexible wire drive belt	Adjustment of tension of Flexible Wire Drive Belt Replacement of Flexible Wire Drive Belt
	Engine rpm is slow	This machine's Owner's Operating Manual
Blade adjustment gets out of order	Insufficient tension of the spring of the pipe with cutter adjustment screw	Adjustment - Adjustment of Cutter Adjustment Spring
	Adhesion or play of the raising and lowering part of the reel housing	Removal and installation of each part - Mower units

Troubleshooting

Problem	Cause	Reference
Blade adjustment gets out of order	Malfunction of the reel bearing	Inspection of each part, repair - Reel housing
	Abrasion of the reel shaft	Removal and installation of each part - Reel cutter
	Insufficient tightening of the reel nuts	Removal and installation of each part - Reel cutter
	Insufficient tightening of the mounting bolts of the bed knife mount	Inspection of each part, repair - Installation of Bed Knife Mounting Assy
Cutting height adjustment gets out of order	Malfunction of the roller bearing	Inspection of each part, repair - Roller - Front roller Inspection of each part, repair - Roller - Rear roller
	Looseness of the cutting height adjustment nuts	This machine's Owner's Operating Manual
	Abrasion of the roller shaft	Inspection of each part, repair - Roller - Front roller Inspection of each part, repair - Roller - Rear roller
Mowed face is not flat.	The cutting heights of the mower units are not consistent	This machine's Owner's Operating Manual
	The edge is rounded	Inspection of each part, repair - Reel cutter
	The operating speed is too fast	Operate at an appropriate speed
The mower units move irregularly	Malfunction of the roller part	Inspection of each part, repair - Roller - Front roller Inspection of each part, repair - Roller - Rear roller
	The operating speed is too fast	Operate at an appropriate speed
The groomer does not rotate	The groomer clutch lever is in "STOP" position	Turn the groomer clutch lever to "NORMAL" or "REVERSE" position
	Malfunction inside the groomer gear case	Inspection of each part, repair - Groomer Assy
Clippings do not enter the grass catcher smoothly	Insufficient adjustment of the reel cover	This machine's Owner's Operating Manual
	Insufficient rotation of the reel cutter	This machine's Owner's Operating Manual
	Wrong installation of the grass catcher	This machine's Owner's Operating Manual
	Insufficient adjustment of the mower mounting bracket	Inspection of each part, repair - Mower mounting bracket
The oil level buzzer sounds	The hydraulic oil level is low	This machine's Owner's Operating Manual
	Malfunction of the oil level switch	Electrical system - Electrical equipment - Level switch

Troubleshooting

Specifications.....	Page 9-2
Maintenance Schedule.....	Page 9-3
Hydraulic circuit diagram.....	Page 9-5
2WD.....	Page 9-5
3WD.....	Page 9-6
Electrical Circuit.....	Page 9-7
Start the engine.....	Page 9-7
Stop the engine.....	Page 9-8
Mower Unit Control.....	Page 9-9
3WD.....	Page 9-10
Buzzers.....	Page 9-11
Work Lamp.....	Page 9-12
Electric wiring diagram.....	Page 9-13
Main Wire.....	Page 9-13
Work Lamp Wire.....	Page 9-14
List of Consumables.....	Page 9-15

Reference

Specifications

LM315GC

			Diesel		
			2WD	3WD	
Main body	Total length		2,155 mm (84.8 in)		
	Total width		1,730 mm (68.11 in)		
	Total height	ROPS		1,660 mm (65.35 in)	
		Steering wheel	Highest tilt position	1,410 mm (55.51 in)	
			Lowest tilt position	1,320 mm (51.97 in)	
	Wheelbase		1,185 mm (46.65 in)		
	Tread (front wheel)		1,255 mm (49.41 in)		
	Weight	Machine (no ROPS, no grass catcher, full oil and fuel)		608 kg (1,340 lb)	617 kg (1,360 lb)
		ROPS		25 kg (55.1 lb)	
		Grass catcher (3 units)		10.2 kg (22.5 lb)	
	Drive (2WD/3WD changeover for 3WD)		2WD	3WD	
	Traveling speed	Forward		0 - 15 km/h (0 - 9.32 mph)	
		Backward		0 - 6km/h (0 - 3.73 mph)	0 - 9 km/h (0 - 5.59 mph)
Steering wheel		Power steering (orbitrol + hydraulic cylinder)			
Brake		Rear one wheel drum mechanical type			
Wheel size	Pneumatic pressure		Front wheel (Option) Smooth 18 x 9.50-8 2P 80 kpa (0.8 kgf/cm ²) (11.60 psi) PillowDia 18 x 8.50-8 2P 100 kpa (1.0 kgf/cm ⁴) (14.50 psi)		
	Rear wheel		Smooth 18 x 9.50-8 2P 80 kpa (0.8 kgf/cm ²) (11.60 psi)		
Operating machine (Mower unit)	Cutting height (when the 2-mm bed knife is used)		2 - 20 mm (0.078 in - 0.78 in)		
	Cutting width: 5 units		152 cm (59.84 in)		
Engine	Model		KubotaD722-E4B		
	Model type		Vertical water-cooled 4-cycle diesel engine		
	Total displacement		719 cm ³ (0.719 L)		
	No load rpm		1,500 - 3,270 rpm		
	Rated output		12.4 KW (16.9 PS)/3000 rpm		
	Fuel consumption		286 g/kW-h (211 g/ps-h) (Rated output)		
	Engine oil in use		D10W-30CF or higher		
	Battery		(Diesel 55B24L)		
Volume	Quantity of engine oil		About 2.8 dm ³ (2.8 L) (0.74 U.S. gal.)		
	Coolant capacity		3.0 dm ³ (3.0 L) (0.79 U.S. gal.)		
	Fuel tank capacity		20.0 dm ³ (20 L) (5.28 U.S. gal.)		
	Hydraulic tank capacity		16.0 dm ³ (16 L) (4.23 U.S. gal.)		

Maintenance Schedule

LM315GC Diesel Model

Follow the maintenance schedule below.

○ ... Inspection, adjustment, supply, cleaning

● ... Replace (first time)

△ ... Replace

Maintenance item		Before work	After work	Every 8 hrs.	Every 50 hrs.	Every 100 hrs.	Every 200 hrs.	Every 250 hrs.	Every 400 hrs.	Every 500 hrs.	Every 1 years	Every 2 years	Every 4 years	Remarks	
Engine	Tightening the parts	○													
	Fuel	○													
	Air cleaner	○					△								
	Engine oil	○		●	△									8 hrs. (first time)	
	Engine oil filter	○			●	△								50 hrs. (first time)	
	Ignition plug	-	-	-	-	-	-	-	-	-	-	-	-	-	-
	Radiator	○													
	Oil cooler	-	-	-	-	-	-	-	-	-	-	-	-	-	-
	Coolant	○			△										
	Fan belt	○										△			
	Battery	○											△		
	Battery fluid	○													
	Cleaning the exterior	○													
Main body	Tightening the parts	○													
	Interlock system	○													
	Emergency switch	-	-	-	-	-	-	-	-	-	-	-	-	-	
	Electrical wiring										○				
	Knife	○													
	Steering chain	-	-	-	-	-	-	-	-	-	-	-	-	-	
	Cutting (or brush) height	○													
	Greasing, oiling			○	○										See greasing points
	Tire	○													
	Rubber crawler	-	-	-	-	-	-	-	-	-	-	-	-	-	-
	V-belt	○										△			
	Brake	○													
	Wire	○						△							
Cover	○														
Oil leakage	○														
Hydraulic Oil	○					●				△				100 hrs. (first time)	

Reference

Maintenance item		Before work	After work	Every 8 hrs.	Every 50 hrs.	Every 100 hrs.	Every 200 hrs.	Every 250 hrs.	Every 400 hrs.	Every 500 hrs.	Every 1 years	Every 2 years	Every 4 years	Remarks	
Main body	Hydraulic oil filter					●				△				100 hrs. (first time)	
	Hydraulic motor oil	-	-	-	-	-	-	-	-	-	-	-	-	-	
	Power unit oil	-	-	-	-	-	-	-	-	-	-	-	-	-	
	Transmission oil	-	-	-	-	-	-	-	-	-	-	-	-	-	
	Hydraulic hose (moving part)	○										△			
	Hydraulic hose (fixed part)	○											△		
	Air cleaner	○					△								
	Electromagnetic pump filter	-	-	-	-	-	-	-	-	-	-	-	-	-	-
	Fuel strainer					○					△				
	Fuel pipe	○													
	Cleaning the exterior	○													
By model	Greasing (center part of the flexible wire)			○											
	Greasing (main body side of the flexible wire)	○													
	Transmission grease											△			

The values for consumables are not guaranteed.
Replace the steering cylinder hoses every 2 years.

Hydraulic circuit diagram

2WD

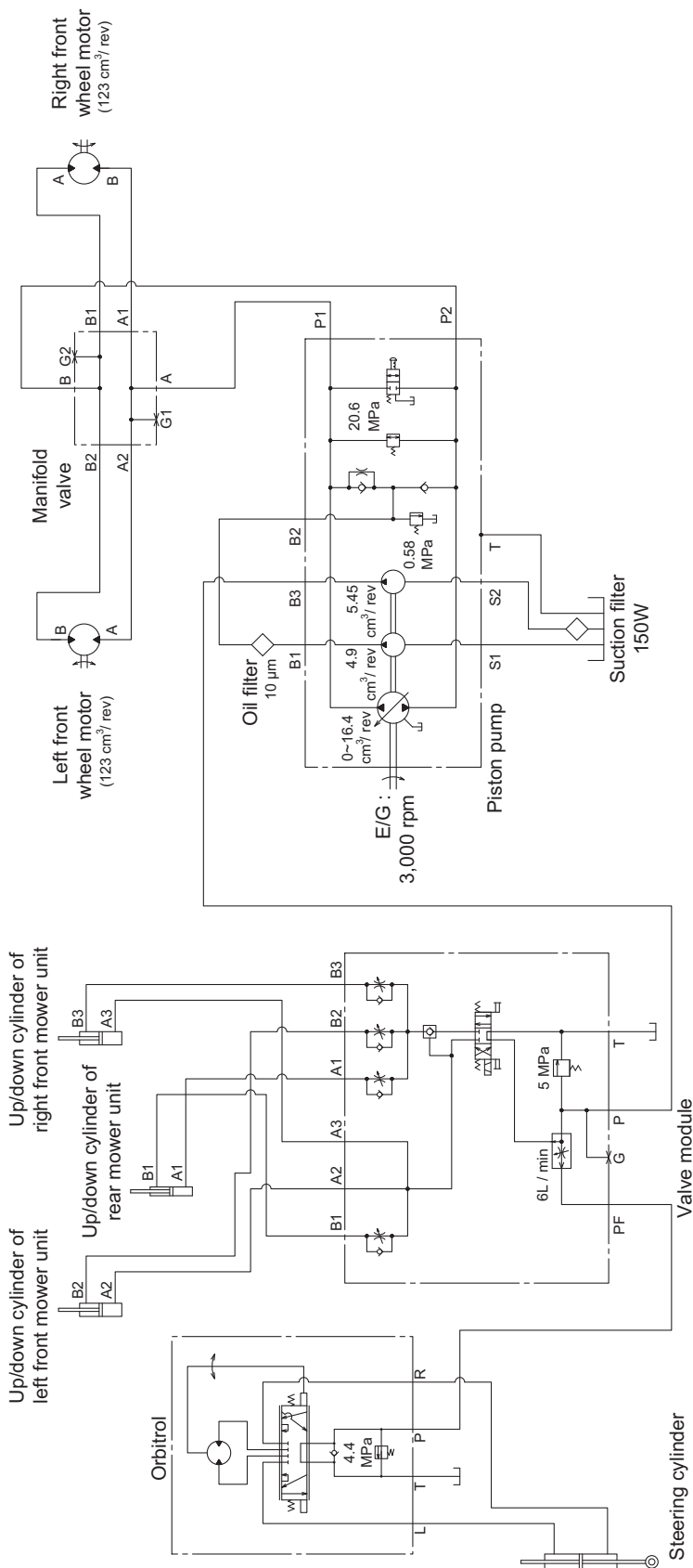

Reference

3WD

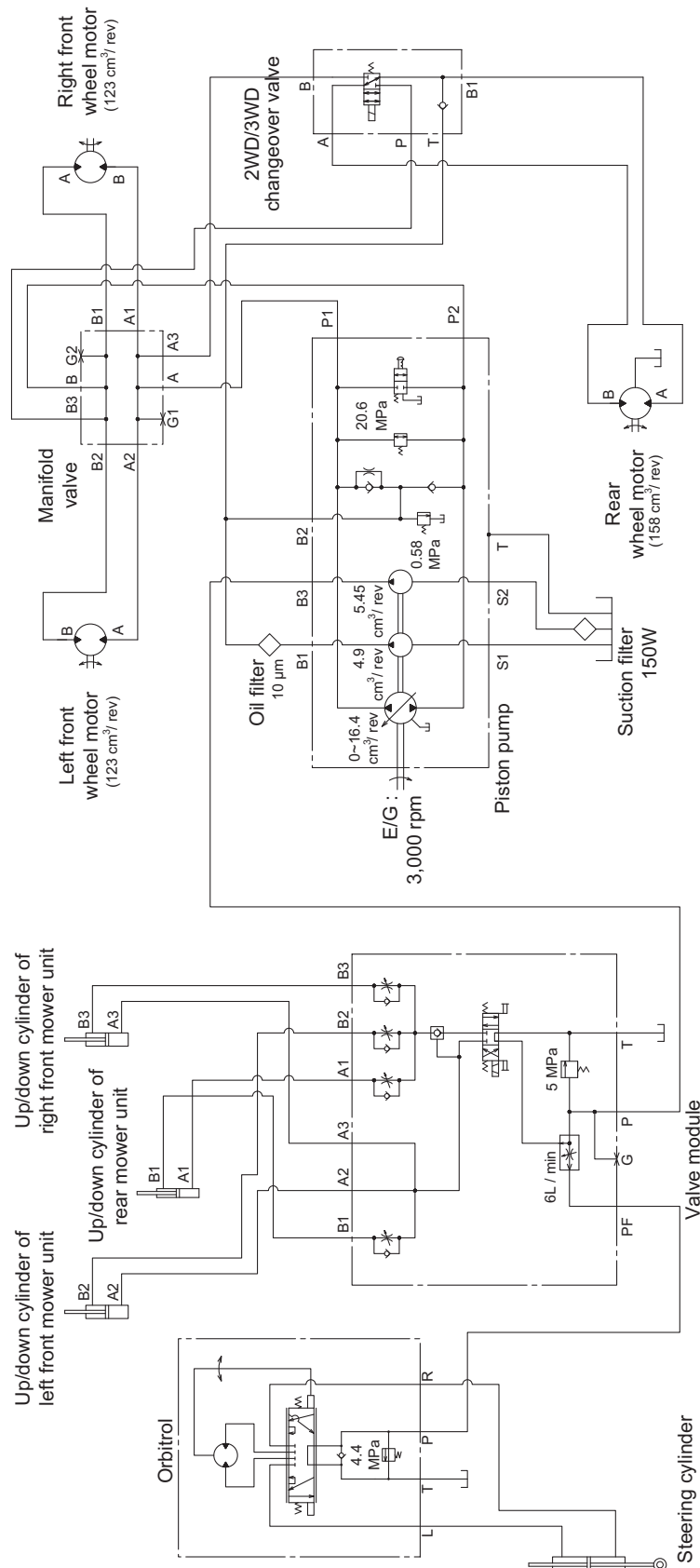

3WD_001

tyg9sz-008

Electrical Circuit

Start the engine

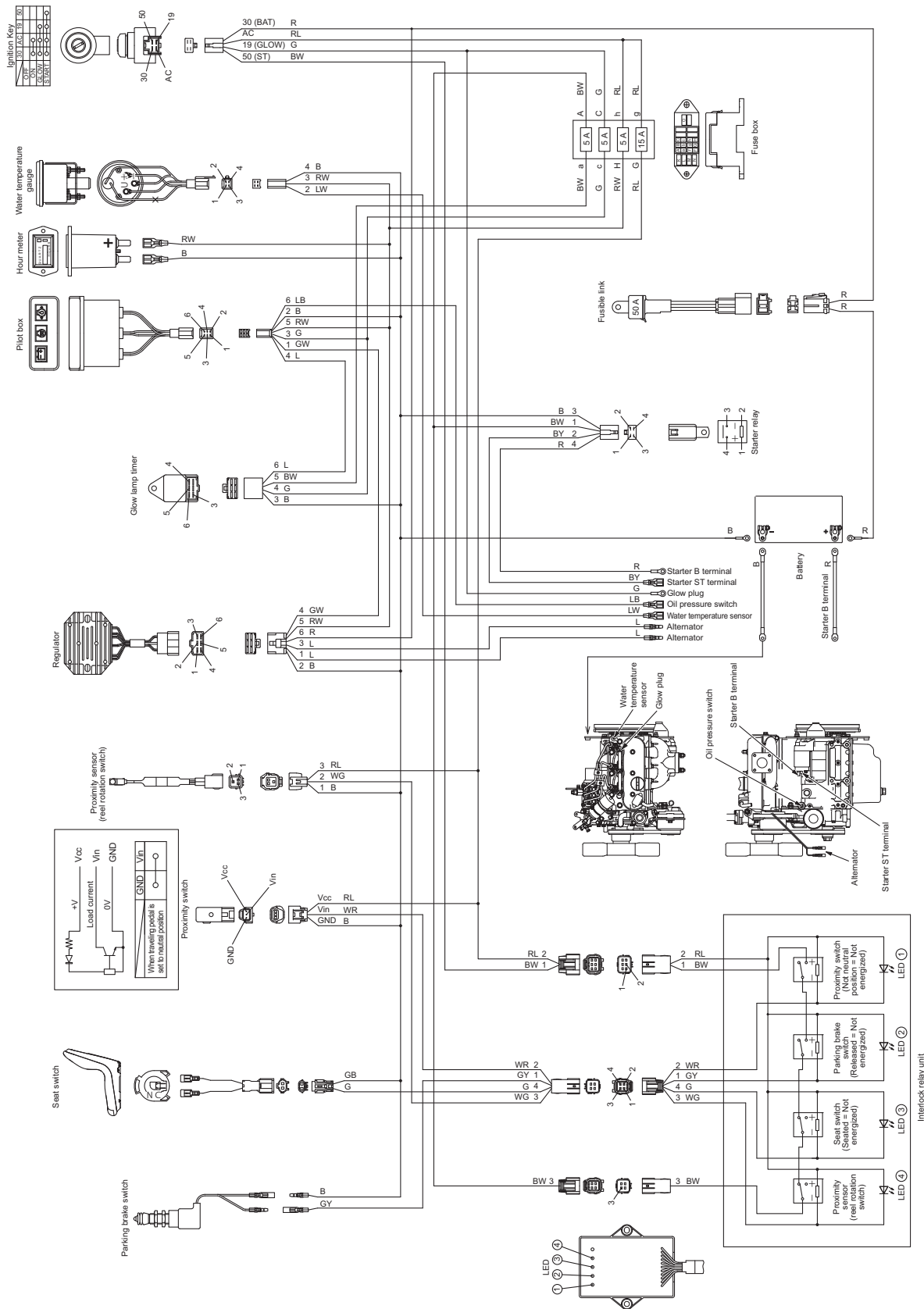

Reference

Stop the engine

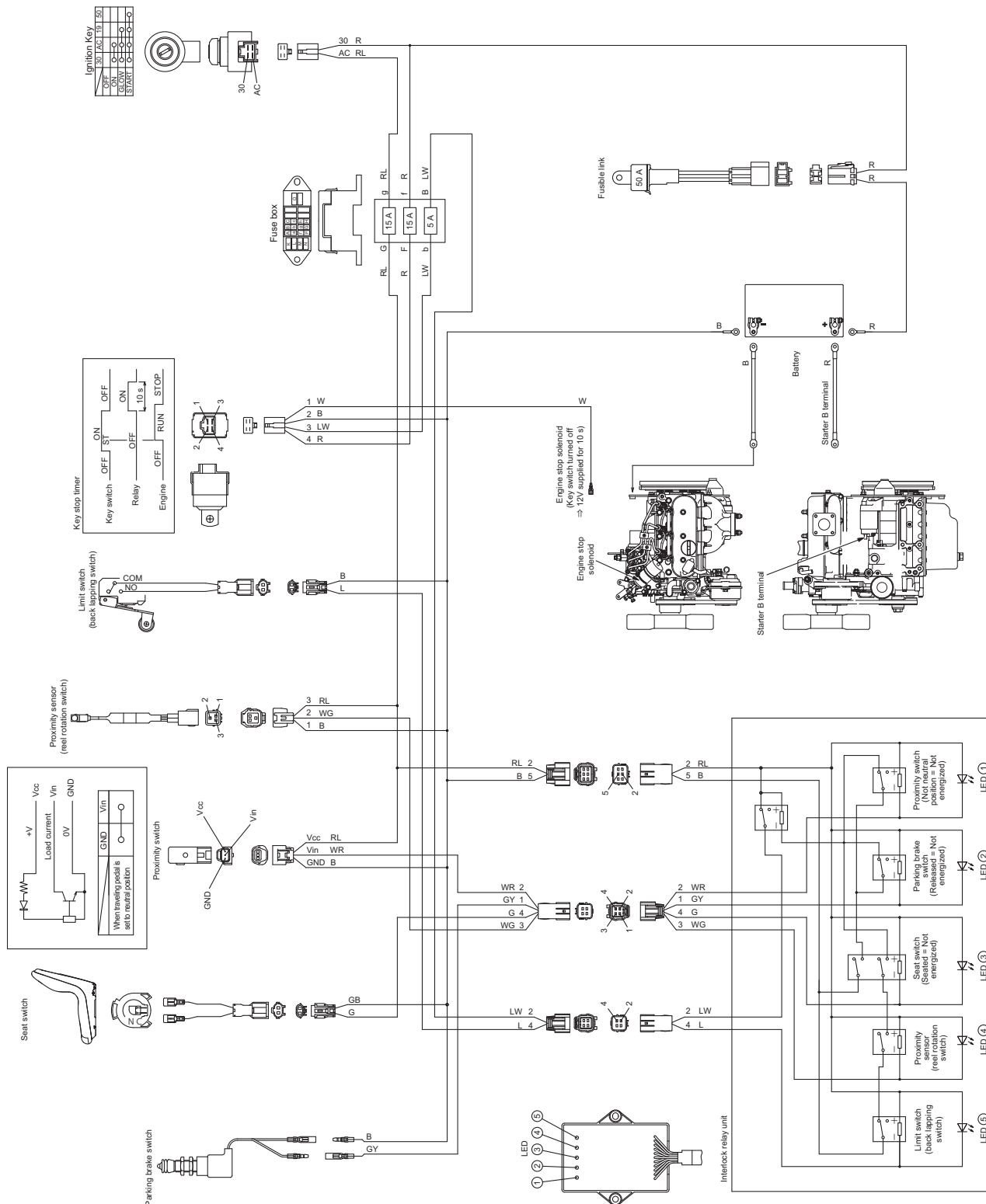

ehc814-002

Stop the engine_001

Mower Unit Control

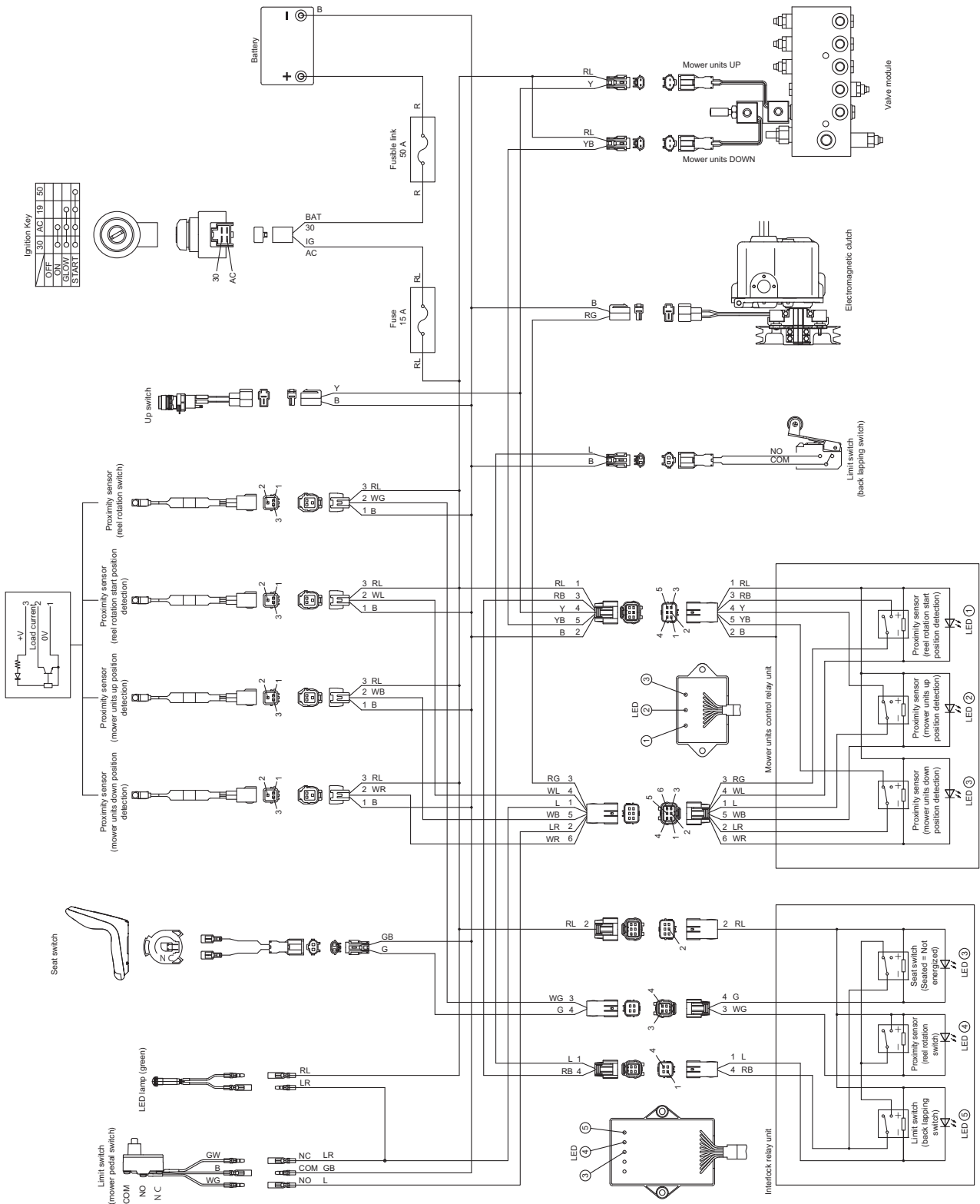

Reference

Reference

3WD

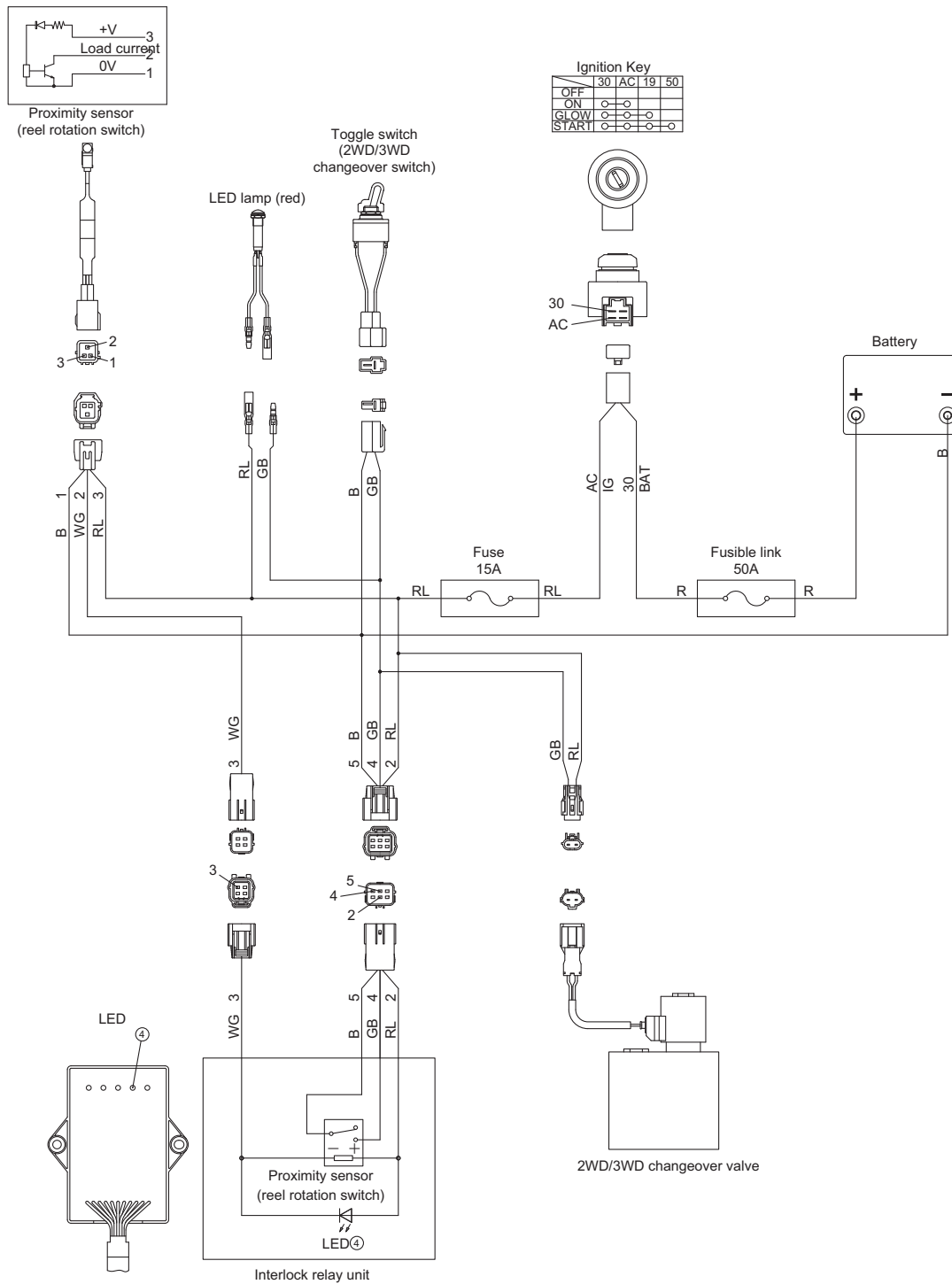

Buzzers

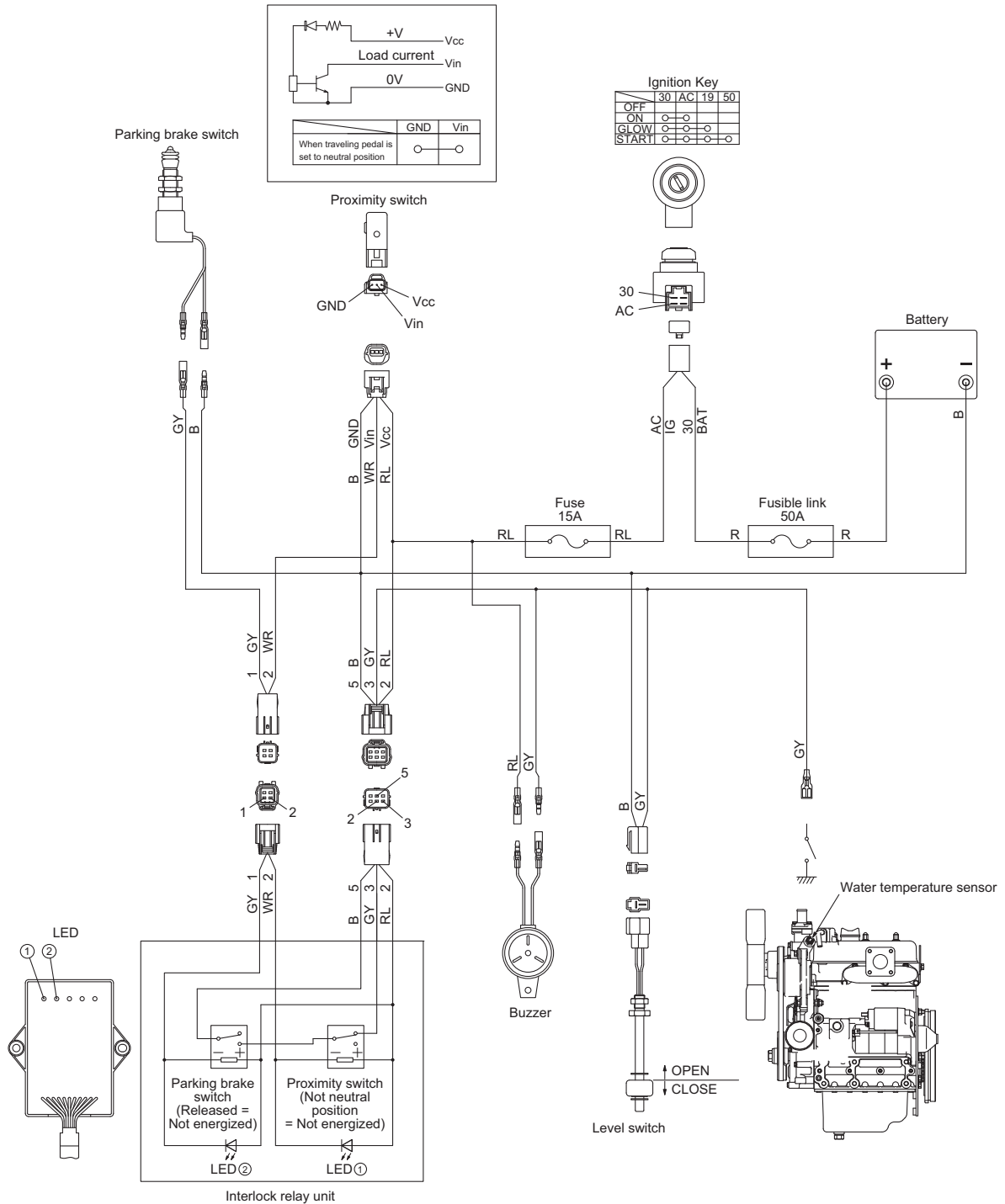

Reference

bcxmb-006

Buzzers_001

Reference

Work Lamp

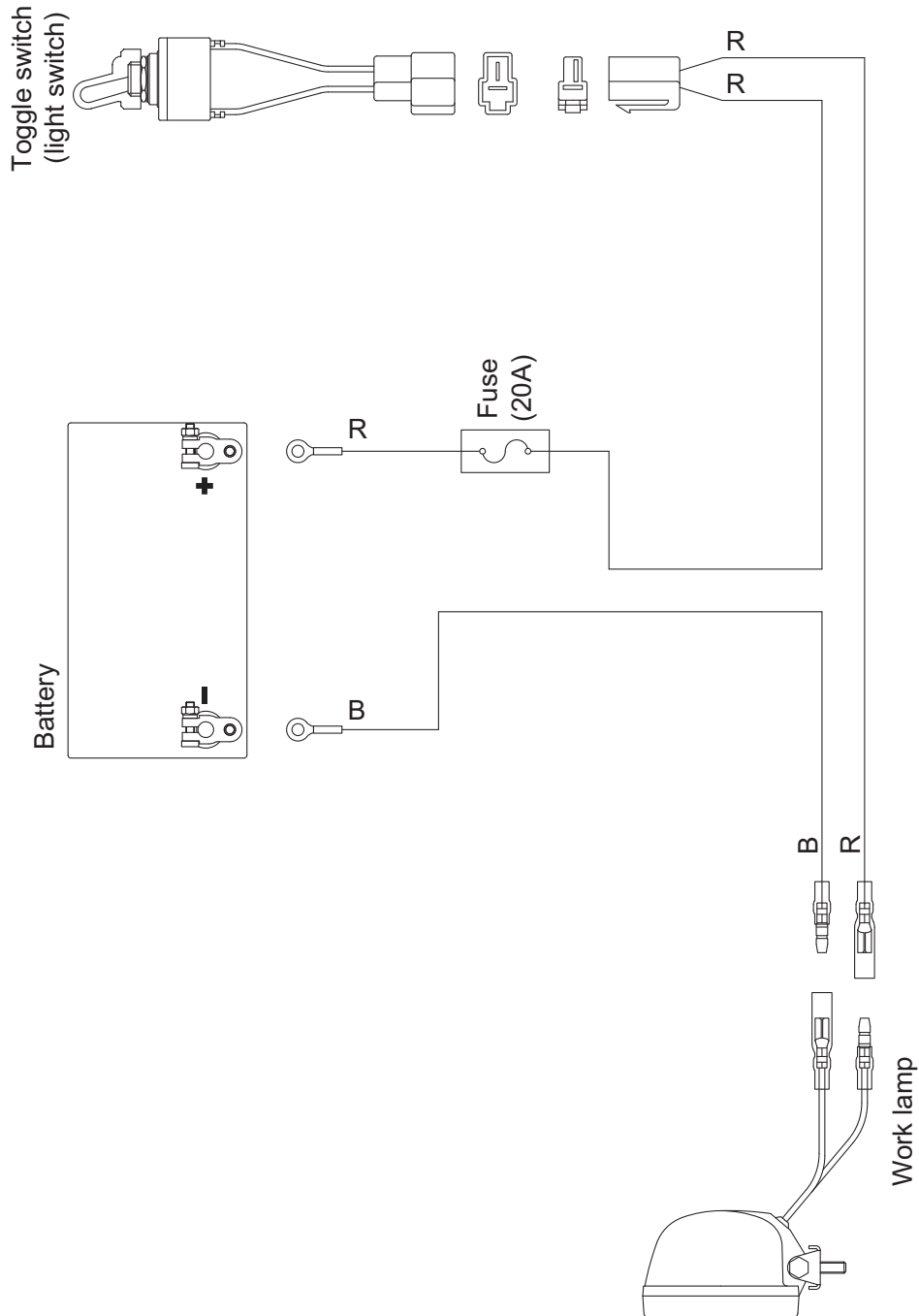

Electric wiring diagram

Main Wire

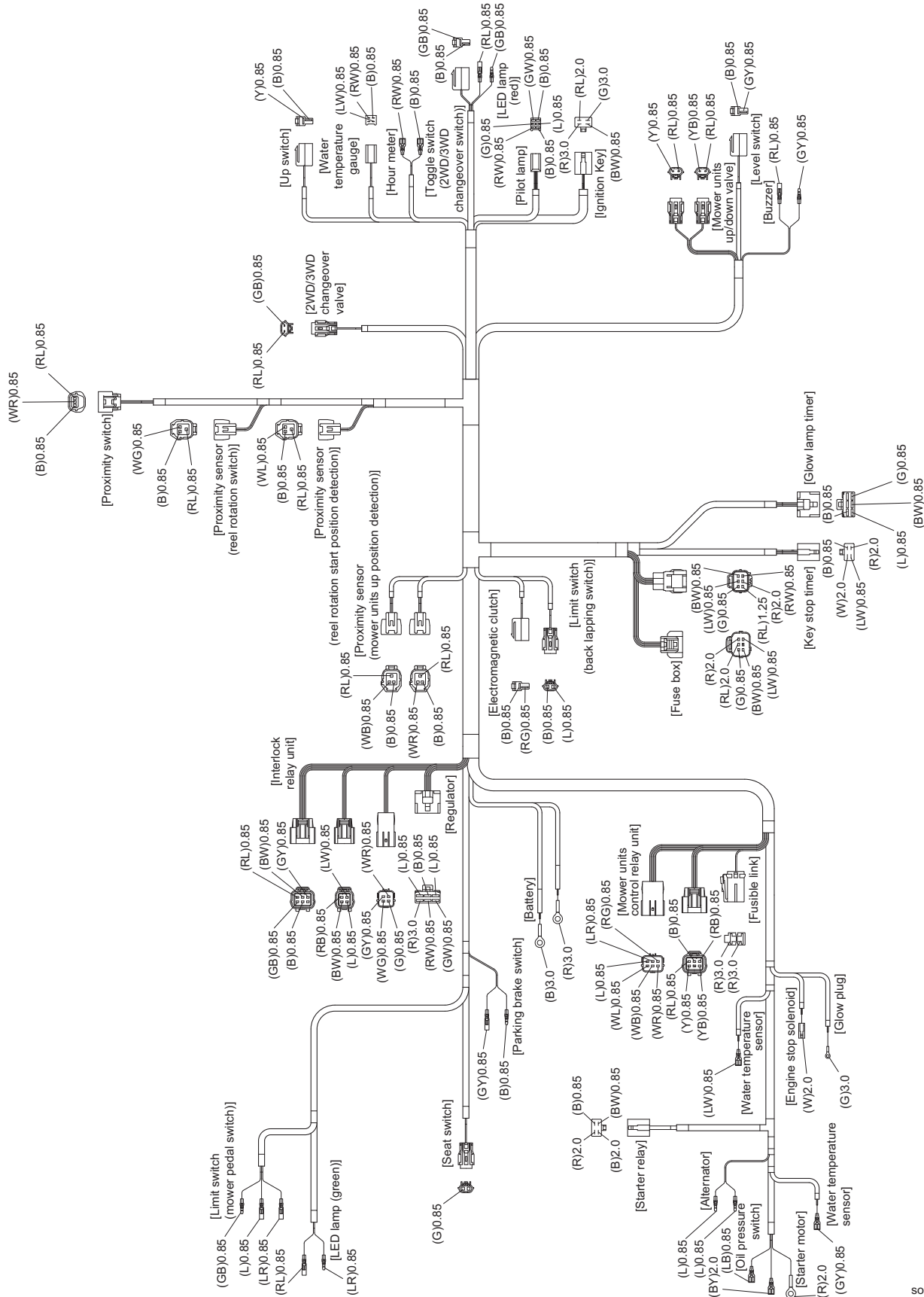

Main Wire_001

Reference

Work Lamp Wire

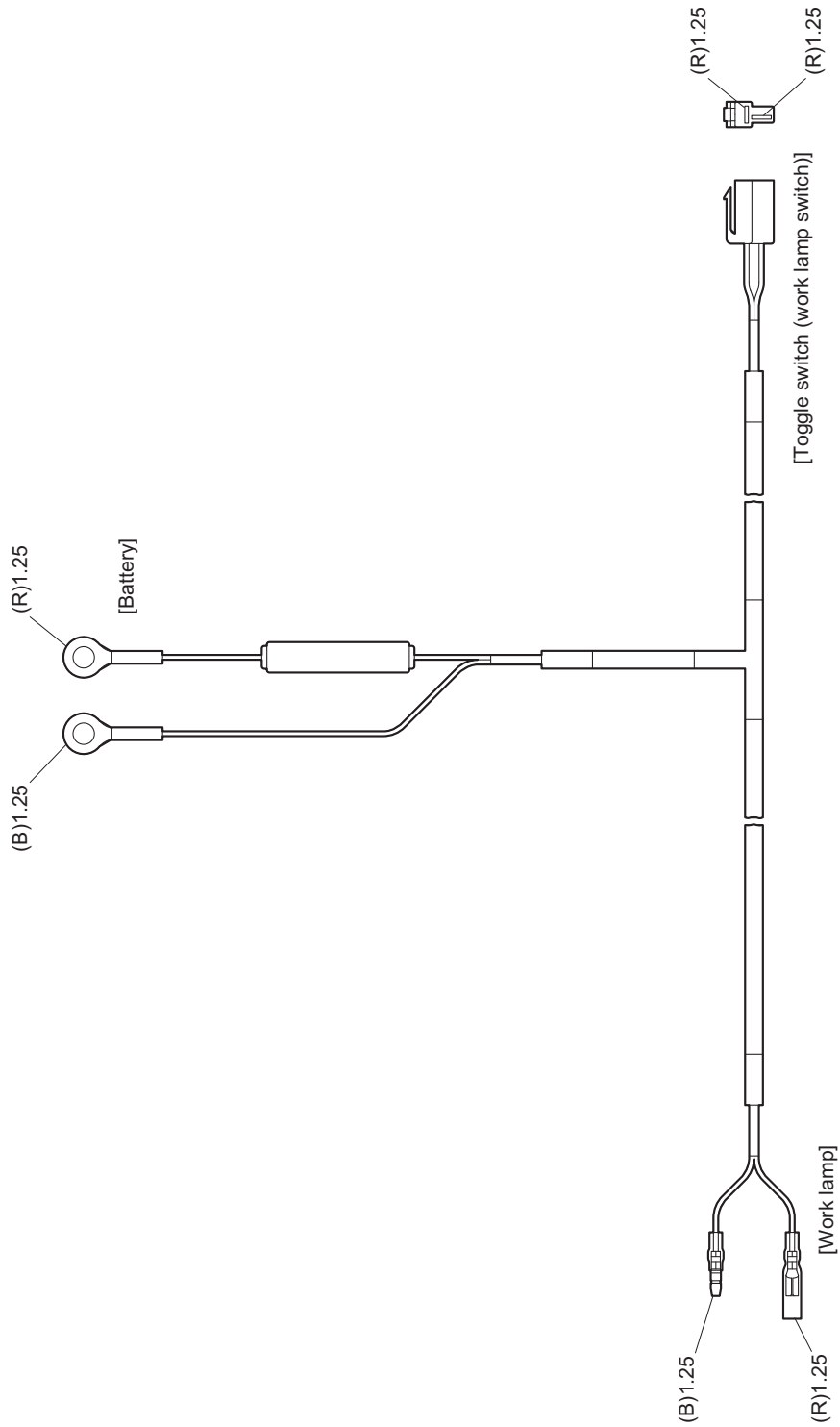

List of Consumables

The consumables are described below.

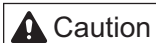

Use tools appropriate for each replacement operation.

	Code	Part name	Qty.	Remarks	
Engine	Fan belt	PF16883-9701-0	Fan belt	1	
	Oil filter	PF15853-3243-0	Filter (oil cartridge)	1	
	Fuel filter	PF1G313-4356-0	Fuel filter element	1	
	Air cleaner element	PFK7311-8239-0	Air cleaner element	1	
	Fuel hose (tank - fuel filter)	K3180002700	Fuel hose FUEL8*1B270	1	
	Fuel hose (Fuel filter - engine)	K3180009000	Fuel hose FUEL8*1B900	1	
	Fuel hose (engine drain - tank)	K3182005700	Fuel hose FUEL4*1B570	1	
Main body (including hydraulic and electrical systems)	Hydraulic suction filter	K3413000050	Suction filter SFT-06-150W	1	Hydraulic tank capacity 16.0 dm ³ (16.0 L) (4.23 U.S. gals)
	Hydraulic oil filter	K3412000050	Replacement filter C-SP04-10	1	
	Hydraulic Oil	K2913100200	Tellus S2 M46 20 L can	1	
	Steering cylinder (K3213000380)	YIS-40F-SK	Steering cylinder seal kit	1	
	Rear mower cylinder (K321200022D)	YIS-30A-SK	Cylinder seal kit	1	
	Right mower and left mower cylinder (K3213000360)	YIS-40A-SK	Cylinder seal kit	1	
	Piston pump (K3241000200)	YB070A-51025	Seal kit for PSV16CHG	1	
	Orbitrol (K3294000130)	YBM0063A	Seal kit for orbitrol RU074	1	
	Front wheel motor (K3291000100)	Y61090S	Seal kit for orbit motor 2000 (for rear)	1	
		Y61091S	Seal kit for orbit motor 2000 (for shaft)	1	
	Rear wheel motor (K3291000130)	Y61090S	Seal kit for orbit motor 2000 (for rear)	1	
		Y61091S	Seal kit for orbit motor 2000 (for shaft)	1	
	Valve module (LM315GB0105Z0)	YGS02-5710	Solenoid valve	1	
		YCCP012L	Coil for solenoid valve	2	

Reference

		Code	Part name	Qty.	Remarks
Main body (including hydraulic and electrical systems)	Mower unit control relay unit	LM315GC1902Z0	Mower up/down control board	1	
	Interlock relay unit	LM315GC1903Z0	Interlock board	1	
	Starter relay	K3681000060	Relay CA1aF-12V-N-5	1	
	Limit switch (Back lapping switch)	K3670000160	Limit switch AZ3526	1	
	Proximity Sensor	K3720000110	Proximity sensor E2S-W23	4	
	Proximity switch	K3720000150	Proximity switch NO	1	
	Limit switch (mower pedal switch)	K3671000130	Limit switch 1BS5000	1	
	Glow lamp timer	PF15694-6599-0	Glow lamp timer	1	
	Fusible link	K3631000100	Plug-in fuse 50 A	1	
	Fuse box	K3631000070	Mini-blade fuse 5 A	4	
		K3631000110	Mini-blade fuse 15 A	2	
	Parking Brake Switch	K3671000030	Safety switch G1780	1	
	Flexible wire	LM315GA0801Z0	Flexible wire	2	
	Flexible wire	LM315GA0802Z0	Outer 1650	2	
	Flexible wire	LM315G-0803Z0	Inner 1712	2	
	Flexible wire	LM315GA0804A0	Length of flexible wire	1	
	Flexible wire	LM315GA0805A0	Outer 2300	1	
	Flexible wire	LM315GA0806Z0	Inner 2362	1	
	Battery	K3600000260	Battery FX55B24L	1	
	Engine pulley cog belt	K2374220410	Cog belt H-PXSB41-2	2	
V-belt	K2324028000	V-belt GLA28A-4	3		
Push-pull cable	K1160121010	Push-pull cable 1210	1		

BARONESS®

Quality on Demand



Postadress:

TRÄDGÅRDSTEKNIK AB
Helsingborgsvägen 578, Varalöv
262 96 ÄNGELHOLM

Telefon : 0431-222 90
Bg.nr : 5743-7980
Org.nr : 556409-6120

URL:

www.tradgardsteknik.se
E-postadress:
info@tradgardsteknik.se